

PipeCut AIR 360

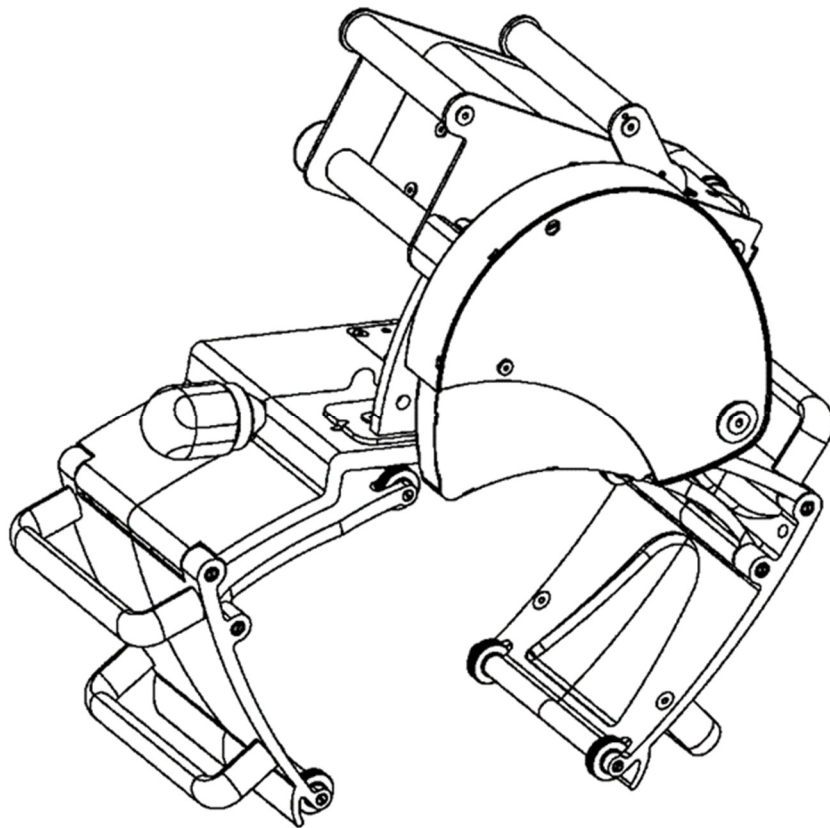

These instructions are translation of the original instructions written in Finnish language.
All instructions are available on web-site: exacttools.com/manuals

Information	
Technical data	4
Delivery content	4
Safety	
General safety regulations	5
Installation, use and maintenance: precautionary measures	10
Guarantee	12
Service	12
Environmental information	12
Operation	
Operational instructions	14
Changing blades	18
Theoretical cutting depths	20

Declaration of Conformity

We declare under our sole responsibility that the pipe cutting machine

Exact PipeCut AIR 360

described under "Technical Data" is in conformity with the following standards or standardization documents:

EN 62841-1:2015 + A11:2022, EN 62841-2-5:2014, EN 55014-1:2017 + A11:2020, EN 55014-2:1997 + A2:2008, EN 61000-3-2:2014, EN 61000-3-3:2013, according to the technical provisions of the directives 2006/42/EC and 2014/30/EU

For more information, please contact Exact Tools at the following address:

The person authorized to compile the technical file:

Marko Törrönen, Chief Technology Officer, marko.torronen@exacttools.com

Helsinki, 02.01.2024

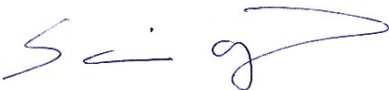

Sami Ojamo
Managing Director
Exact Tools Oy
Särkiniementie 5 B 64
FI-00210 Helsinki
Finland

Exact PipeCut AIR 360 saw

No-load speed	4000 1/min
Blade diameter	140 mm (5.6"), 165 mm (6.50"), 180 mm (7.2")
Mounting bore	62 mm (2.44")
Weight	26,8 kg (59 lbs)
Range of use, pipe OD	75 mm–360 mm (3"–14")
Max. pipe wall, plastics and cast iron	45 mm (1.8")
Vibration, a_h , ISO 28927-8	Less than 2,5 m/s ²
Vibration uncertainty, K	1,5 m/s ²
LpA (sound pressure), ISO 15744	95,3 dB(A) No load 113,0 dB(A) No load, full speed
KpA (sound pressure uncertainty)	2,5 dB(A)
LWA (acoustic power), ISO 15744	106,3 dB(A) No load 124,0 dB(A) No load, full speed
KWA (acoustic power uncertainty)	2,5 dB(A)
Air pressure max.	6,3bar (90PSI)
Free air volume, minimum	4,5m ³ (159CFM)
Air quality requirement	40µm filtering or better
Operating temperature	+40°C...-20°C / 104F...-4F
Recommended lubrication oil	Mobil DTE 24 ISO VG32, For temperatures below +5°C (41 °F) a thinner oil must be used.

NOTE! If the recommended pressure and air quantity are not attained, the machine can be used normally, but the machine's efficiency and working speed will decrease correspondingly. The machine is not recommended for use in conditions where the recommended pressure and air volume are less than half of the recommended values.

DELIVERY CONTENT

Package contents, please check that the package contains the following items:

1. Exact PipeCut AIR 360
2. Operating instructions
3. 5mm allen key
4. Open end wrench with oil piston push down tool
5. Funnel

NOTE:

- Saw Blade/Diamond Disc not included
- Additional hose or hose connection not included

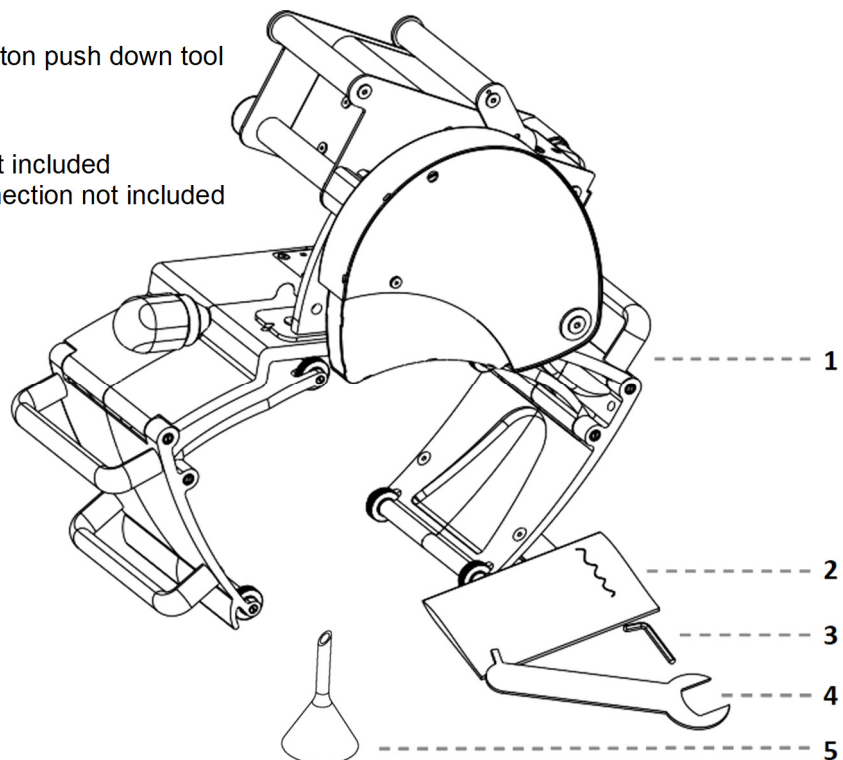



Operating, safety, and servicing instructions

You now have the use of a completely new type of tool developed as a safe alternative to dangerous tools used to cut round pipes. The extremely effective Exact PipeCut AIR 360 has been designed to cut various types of metals and plastics. It is absolutely essential that you carefully read and understand these operating, safety, and servicing instructions before using the pipe saw.

Keep this manual conveniently within reach of all pipe saw users. Make sure that all persons using the saw have read and understood the dangers and operating instructions specified in this manual, and always follow the rules and regulations provided by occupational safety agencies. The Exact PipeCut AIR 360 pipe saw is for professional use only.

The definitions below describe the level of severity for each signal word. Please read the manual and pay attention to these symbols

 **DANGER:** Indicates an imminently hazardous situation which, if not avoided, will result in serious injury or in extreme cases a fatality

 **WARNING:** Indicates a potentially hazardous situation which, if not avoided, could result in serious injury or in extreme cases a fatality

 **CAUTION:** Indicates a potentially hazardous situation which, if not avoided, may result in minor or moderate injury.

 **NOTICE:** Indicates a practice not related to personal injury which, if not avoided, may result in property damage.

Symbols found on the machine.



Use ear protection.



Use gloves.



Read instructions before use.



Saw blade: Saw blade behind this cover, do not insert fingers or other body parts inside this cover.

General safety regulations

To reduce the risks of electric shock, fire, and injury to persons, read all the instructions before using the tool.

Our objective is to manufacture tools that enhance working safety and efficiency. The most important safety factor for this and any other tool is ITS USER. Your diligence and judgement are the best protection against accidents and injuries.

- Only qualified and trained operators should install, adjust or use the circular saw.
- Do not modify this circular saw. Modifications can reduce the effectiveness of safety measures and increase the risks to the operator.
- Do not discard the safety instructions; give them to the operator.
- Do not use the circular saw if it has been damaged.
- Tools shall be inspected periodically to verify that the rating plate displaying the nominal speed or operational pressure or stickers warning of dangers, are legible and have not become detached. The employer/user shall contact the manufacturer to obtain replacement marking labels where necessary.

WARNINGS RELATED TO THE COMPRESSED AIR FEED AND COUPLINGS

- Air under pressure can cause severe injury:
 - Always shut off air supply, drain hose of air pressure and disconnect tool from air supply when not in use, before changing accessories or when making repairs
 - Never direct air at yourself or anyone else.
- Whipping hoses can cause severe injury. Always check for damaged or loose hoses and fittings.
- Do not use quick disconnect couplings at tool inlet for impact and impulse wrenches. Use hardened steel (or material with comparable shock resistance) threaded hose fittings.
- Whenever universal twist couplings (claw couplings) are used, lock pins shall be installed and whipcheck safety cables shall be used to safeguard against possible hose-to-tool and hose-to-hose connection failure. Check the use of the couplings with the applicable safety instructions provided by the manufacturer.
- Do not exceed the maximum air pressure stated on the tool. The air pressure must not exceed 6.3 bar (90 PSI [Pounds per square inch]) or the pressure specified on the tool's rating plate. Exceeding the pressure recommendation can result in the machine's breakage or a hazardous situation.
- Never carry an air tool by the hose.
- Do not inspect or clean the tool while the pneumatic power source is connected. Accidental engagement of the tool can cause serious injury. After the power source shutoff, the hose is emptied by pushing the START button (Picture A /A1, page 13). The machine will run for a few seconds, after which the hose will be emptied of air. Watch out for

the spinning blade and make sure that nothing has been caught in the saw's blade or other parts. Open the coupling only when you are sure that the hose is unpressurized.

- If general purpose threaded couplings are used, locking pins must also be installed.
- Check the hose's condition before installation. A broken or worn out hose may cause a hazardous situation.

ENTANGLEMENT HAZARDS

- Stay clear of spinning grinding disks or blades. Note that the blade will continue to spin after the closing of the START valve, and it may continue spinning for several seconds.
- Entangled clothes, gloves, jewelry, ties, scarfs or long hair in the tool or its accessories can cause choking, scalp injuries, and/or deep wounds.

Never open the blade guard (Picture A / A5, page 13) if you are not sure if the blade or grinding disk has stopped spinning.

PROJECTILE HAZARDS

- Failure of the workpiece, or accessories, or even of the inserted tool itself, can generate high-velocity projectiles.
- The machining of steel and other materials can quickly generate flying debris. Even small objects can injure the eyes and cause blindness.
- Always wear impact-resistant eye protection during the operation of the circular saw. The grade of protection required should be assessed for each use.
- Make sure that other users in the same area are also wearing protective goggles and safety masks.
- Make sure that the pipe to be cut is firmly supported. A weakly or improperly supported pipe may cause a hazardous situation.
- Make sure that the sparks generated by the machine can never, under any circumstances, come into contact with flammable and/or potentially explosive materials or liquids.
- Make sure that sparks or shavings pose no danger to other persons at the job site.
- Ensure that the saw blade or cutter is properly clamped.

ACCESSORY HAZARDS

- Before changing a blade, always shut off the air feed, release the air pressure from the hose and detach the tool from the air feed source.
- Use only the recommended sizes and types of blades, do not use other types or sizes of accessories or consumables.
- Avoid direct contact with the inserted tool during and after use as it can be hot or sharp.
- Inspect the saw blade before use. Do not use saw blades which may have been dropped or which are chipped, cracked or otherwise defective.

OPERATIONAL RISKS

- Users and servicers must be able to physically handle the tool's size, weight, and power.

- Hold the tool properly: be ready to react to any abnormal or sudden movement – keep both hands ready.
- Never use the tool unless the blade is aligned with the material to be cut.
- Avoid contact with the saw blade, knife or cutter to prevent the cutting of hands and other body parts.
- The PipeCut AIR 360 is designed to be used with a blade guard that must always be in place to provide protection from shavings and other debris.
- Guards shall be securely in place and in good functional condition.
- Damaged, bent or severely worn guards shall be replaced with the tool manufacturer's recommended guards.
- Make sure that retractable guards return rapidly to their fully-closed position whenever released from the open position.
- Retractable guards shall never be clamped or tied in an open position or otherwise disabled.
- Use of the tool may expose the operator's hand to hazards including cuts and abrasion and heat. Wear suitable gloves to protect hands.
- Hold the tool correctly: be ready to counteract normal or sudden movements and have both hands available.
- Maintain a balanced body position and secure footing.
- Avoid injury by cutting or severing: avoid contact with saw blade, cutter or knife whenever the energy supply is connected to the tool. Wear protective equipment, such as gloves, apron and helmet.
- Injury can be caused by uncontrolled movements of the tool: always ensure that all of the guide plate (if fitted) is held firmly against the workpiece.
- Cutting with these tools creates sharp edges; wear gloves to protect hands.
- Release the start-and-stop device in the case of an interruption of the energy supply.
- Use only lubricants recommended by the manufacturer.
- Personal protective safety glasses shall be used; suitable gloves and protective clothing are recommended.
- Be aware that there is a running-on of the rotary inserted tool after the start-and-stop device has been released.
- Never move the machine while the motor is running, or the blade is rotating.
- Do not use the tool if you are tired or your alertness has become impaired for health reasons.
- Do not start working if your foothold or balance is unsteady. Falling while holding a saw can cause a hazardous situation.

REPETITIVE MOTIONS HAZARDS

- When operating the tool, the user may experience discomfort in hands, arms, shoulders, the neck, and other parts of the body.
- Work with a comfortable but secure stance and avoid an awkward or un- balanced working position. Varying your position during longer tasks can minimize discomfort and fatigue.

- Do not ignore symptoms such as continuous or periodic discomfort, pain, anxiety, ache, tingling, numbness, a burning sensation, or stiffness. Stop using the tool, inform your employer, and contact a doctor.

NOISE HAZARDS

- Loud noises can cause permanent hearing defects and other problems such as tinnitus. Therefore, a risk assessment and implementation of appropriate controls for these hazards are essential.
- Appropriate controls to reduce the risk may include actions, such as damping materials to prevent workpieces from “ringing”.
- Use hearing protection in accordance with the employer’s instructions and as required by occupational health and safety regulations
- Operate and maintain the circular, oscillating or reciprocating saw as recommended in the instruction handbook, to prevent an unnecessary increase in noise levels.
- Select, maintain and replace the consumable/inserted tool as recommended in the instruction handbook, to prevent an unnecessary increase in noise.
- If the circular, oscillating or reciprocating saw has a silencer, always ensure it is in place and in good working order whenever the tool is being operated.

VIBRATION HAZARDS

- Exposure to vibration can cause disabling damage to the nerves and blood supply of the hands and arms.
- Wear warm clothing when working in cold conditions and keep your hands warm and dry.
- If you experience numbness, tingling, pain or whitening of the skin in your fingers or hands, stop using the circular, oscillating or reciprocating saw, tell your employer and consult a physician.
- Operate and maintain the circular, oscillating or reciprocating saw as recommended in the instruction handbook to prevent an unnecessary increase in vibration levels.
- Select, maintain and replace the consumable/inserted tool as recommended in the instruction handbook, to prevent an unnecessary increase in vibration levels.
- Support the weight of the tool in a stand, tensioner or balancer, if possible.
- Hold the tool with a light, but safe, grip taking account of the required hand-reaction forces, because the risk from vibration is generally greater when the grip force is higher.
- Improper mounting of the saw blade can cause excessive vibration levels.

WORKPLACE HAZARDS

- Keep the work area clean and well lighted. Cluttered benches and dark areas increase the risks of electric shock, fire, and injury to persons.
- Do not use the saw in areas or on terrain where there is the danger of falling or slipping. Make sure that your working position is as steady as possible and that you have a secure foothold.
- Always make sure that the ditch or shaft in which you are working is properly reinforced and that its edges are not in danger of collapsing. Make sure that the terrain is not in danger of giving way or settling.
- Proceed with care in unfamiliar surroundings. There can be hidden hazards, such as electricity or other utility lines.
- Ensure that there are no electrical cables, gas pipes, etc., which can cause a hazard if damaged by use of the tool.
- If the cutting operation is in a ditch or trench, access to the STOP button may be limited. Always have a co-worker be ready to turn off the air feed to the tool in the event of an emergency. A separate air feed with a shutoff device can also be used for emergency situations.
- **Do not operate the tool in explosive atmospheres, such as in the presence of flammable liquids, gases, or dust.** The tool can create sparks resulting in the ignition of the dust or fumes.
- The circular, oscillating or reciprocating saw is not intended for use in potentially explosive atmospheres and is not insulated against coming into contact with electric power.
- Slips, trips and falls are major causes of workplace injury. Be aware of slippery surfaces caused by use of the tool and also of trip hazards caused by the air line or hydraulic hose.
- Keep bystanders, children, and visitors away while operating the tool. Distractions can result in the loss of control of the tool.

DUST AND FUME HAZARDS

- Dusts and fumes generated when using circular, oscillating and reciprocating saws can cause ill health (for example cancer, birth defects, asthma and/or dermatitis); risk assessment and implementation of appropriate controls for these hazards are essential.
- Risk assessment should include dust created by the use of the tool and the potential for disturbing existing dust.
- Operate and maintain the circular, oscillating or reciprocating saw as recommended in the instruction handbook, in order to minimize dust or fume emissions.
- Direct the exhaust so as to minimize disturbance of dust in a dust-filled environment.
- Where dusts or fumes are created, the priority shall be to control them at the point of emission.
- All integral features or accessories for the collection, extraction or suppression of airborne dust

or fumes should be correctly used and maintained in accordance with the manufacturer's instructions.

- Select, maintain and replace the consumable/inserted tool as recommended in the instruction handbook to prevent an unnecessary increase in dust or fumes.
- Warnings shall be given against the risk of explosion or fire due to the material being processed.
- Use respiratory protection in accordance with the employer's instructions and as required by occupational health and safety regulations.
- Working in certain materials creates emission of dust and fumes, causing potentially explosive environments.
- Avoid the inhalation of dust and vapors, as well as the handling of job site waste that could cause health hazards such as, for example, cancer, birth defects, asthma, and/or dermatitis. Use dust extraction equipment and a breathing mask when the material to be cut releases airborne particles.
- Some sawing generates dust containing chemicals that, according to the state of California, can cause cancer, birth defects, and other reproductive harm.

Examples of these kinds of chemicals include:

- lead from lead-based paints,
- crystalline silica from bricks, cement, and other masonry products,
- arsenic and chromium from chemically-treated rubber.

Your risk from these exposures will vary depending on how often you do this type of work.

To reduce your exposure to these chemicals, work in a well ventilated area and use approved protective equipment such as dust masks specifically designed to filter out microscopic particles. Working without the appropriate protective equipment is prohibited.



**DANGER: Explosives and flammable materials, liquids and gases:
Danger of explosion**

If used in explosive atmospheres, the tool may cause an explosion and/or fire.

Explosions are dangerous and may cause extremely serious accidents, injuries, or death. Because the tool often creates sparks while sawing, it must never be used near any kind of potentially explosive or highly flammable material, liquid, or gas. Thoroughly familiarize yourself with the national, state-specific, and local safety instructions related to working near or among, explosive materials.

- Never use the tool near explosives or highly flammable materials, liquids, or gases.
- Never work in highly flammable or explosive atmospheres.
- Make sure that your work area has no hidden gas sources or explosives.
- If there are explosives, highly flammable materials, liquids, or gases at your job site, make sure that they do not pose a danger and cannot

come into contact with sparks created by the saw.

AIR SOURCE

- a) **Never connect to an air source that is capable of exceeding 200 psi** (Pounds per square inch). Over pressurizing the tool can result in bursting, abnormal operation, breakage of the tool or serious injury to persons. Use only clean, dry, regulated compressed air at the rated pressure or within the rated pressure range as marked on the tool. Always verify prior to using the tool that the air source has been adjusted to the rated air pressure or within the rated air-pressure range.
- b) **Never use oxygen, carbon dioxide, combustible gases or any bottled gas as an air source for the tool.** Such gases are capable of explosion and serious injury to persons.
- c) Overspeed caused by excessive air pressure should be avoided with the pressure regulators. Recommended pressures and air quantities must not be exceeded when using the machine. Excessive pressure or air quantities may cause the breakage of the machine, blade, and accessories, or a hazardous situation resulting in serious personal injury or damage to the equipment.
- d) Couplings and air hoses must be in good condition. Check the couplings, air hoses, and compressor before use. Never work with a damaged coupling, air hose or compressor.

Safety information

⚠ DANGER: Failure to comply with these operating instructions may result in serious injury or death.

- Make sure that the pipe being cut is correctly supported, and that each end of the pipe on both sides of the sawing point cannot collapse uncontrollably as the pipe is being cut.
- Make sure that sparks do not endanger people or materials. Sparks may cause accidents if they come into contact with flammable materials, liquids, or gases. See the section Explosives and Flammable Materials, Liquids and Gases, page 6.
- Personal protection equipment must be used as described in the chapter Personal Protection Equipment, page 6.
- Slipping, stumbling, or falling must be indicated as the reason for a serious accident or fatality. Watch out for excessively long hoses left at the job site.
- Work carefully in unfamiliar locations. For example, hidden electrical cables may cause a danger.
- Maintain a balanced position and a steady foothold.
- If an improperly installed or damaged tool vibrates excessively, react quickly. Shut off the device or cut off the air pressure if possible.
- Stay clear of spinning blades; the rotary motion may continue for several seconds after the air feed has been shut off. Do not detach the pipe saw from the pipe before the spinning motion has stopped.
- Note that compressed air left in the hose can cause an unintentional startup. Always empty the hose carefully after use. Never detach a pressurized hose.
- If there is a fault in the energy feed, press the STOP button (Picture A / A2, page 13).

Personal safety precautions and requirements

Only trained persons familiar with all general safety regulations, as well as the possible dangers occurring at job sites, may use this tool.

Users are capable if they:

- are able to handle the size, weight, and power of the device.
- are trained to use this device according to national, state-specific, and local instructions.
- are familiar with, and understand, all national, state-specific, and local safety regulations, as well as precautionary measures aimed at accident prevention.
- have read and understood this manual.
- have not ingested alcohol, drugs, or medications impairing alertness or the ability to work.

Personal safety

- WEAR APPROVED HEARING AND EYE PROTECTION
- WEAR APPROVED HAND PROTECTION

- **⚠ WARNING: READ AND UNDERSTAND THE INSTRUCTION MANUAL PRIOR TO USE**
 - a) **Stay alert. Watch what you are doing and use common sense when operating the tool. Do not use the tool while tired or under the influence of drugs, alcohol, or medication.** A moment of inattention while operating the tool increases the risk of injury to persons.
 - b) **Dress properly. Do not wear loose clothing or jewelry. Contain long hair. Keep hair, clothing, and gloves away from moving parts.** Loose clothes, jewelry, or long hair increases the risk of injury to persons as a result of being caught in moving parts.
 - c) **Avoid unintentional starting. Be sure the switch is off before connecting to the air supply.** Do not carry the tool with your finger on the switch or connect the tool to the air supply with the switch on.
 - d) **Do not overreach. Keep proper footing and balance at all times.** Proper footing and balance enable better control of the tool in unexpected situations.
 - e) **Use safety equipment.** A dust mask, non-skid safety shoes and a hard hat must be used for the applicable conditions.
 - f) **Always wear eye protection.**
 - g) **Always wear hearing protection when using the tool.** Prolonged exposure to high intensity noise is able to cause hearing loss.
 - h) **⚠ WARNING: Risk of electric shock. This tool is not provided with an insulated gripping surface. Contact with a live wire will also make exposed metal parts of the tool live and a risk of electric shock to the operator.**
 - i) **Avoid body contact with grounded surfaces such as pipes, radiators, ranges and refrigerators.** There is an increased risk of electric shock if your body is grounded.
 - j) **Explore the workpiece to avoid contact with hidden wiring.** Thoroughly investigate the workpiece for possible hidden wiring before performing work. Contact with live wiring will shock the operator.

Personal protective equipment

⚠ DANGER: Danger of being caught in moving parts:

- Do not wear loose jewelry, clothing, or uniforms. Make sure that possible shirtsleeves, shoelaces, and/or pants cannot be caught by the machine's moving parts or become entangled with any other object or natural feature at the job site.
- To minimize the danger of choking, make sure that any collar, tie, or hood cannot become entangled with the device, cords, or accessories.

- To minimize the danger of entanglement, make sure that hair and headgear cannot be caught by the device's moving parts, cords, or accessories.

Personal protective equipment must conform to the applicable health and safety requirements. Always use the following personal protective equipment:

- Hard hat conforming to occupational safety requirements.
- Sufficient hearing protection.
- Safety goggles or visor for eye protection.
- Cut-resistant safety gloves.
- Non-skid safety shoes conforming to occupational safety regulations.
- Breathing mask.



WARNING: Intoxicants:

Drugs, alcohol, and medications may weaken attention, judgement, and/or the ability to concentrate. Impaired reflexes, unsteady balance, hallucinations, and miscalculations may cause serious workplace accidents such as personal injuries, damage to tools and property, or death.

Never use the tool if you are under the influence of alcohol, intoxicating medications, and/or drugs.

If you know about, or notice someone using alcohol, drugs, or intoxicating medications, make sure that he or she is not using the tool.

Installation, use and maintenance: precautionary measures

This tool may be installed, stored, maintained, and disposed only by persons who:

- are physically able to handle the size, weight, and power of the device.
- are familiar with all relevant national, state-specific, and local safety regulations, as well as precautionary measures aimed at accident prevention.
- have read and understood these operating instructions.
- have not ingested alcohol, drugs, or medications impairing alertness or the ability to work.



DANGER: Electric shock

If the device comes into contact with electric circuits or other power sources, it may cause serious injury or death. Always make sure there are no cables, wires, or circuits running inside or near the pipe to be cut that could conduct electricity to the device or user.

- Do not work near electrical circuits or other sources of electric currents.
- Make sure that your working area has no hidden electrical circuits and that the pipe to be sawn is

not in contact with any kind of electrical circuit, power source, cable, wire, or transformer.

- Make sure that any water coming from inside the pipe or existing at the job site does not cause the danger of electric shock, and that no water comes into contact with any kind of electrical circuit, power source, cable, wire, or transformer.



WARNING: Compressed air can cause serious injuries

- Always close the air feed, release the pressure from the piping, and detach the tool from the air feed when it is not being used, repaired, or adjusted, for example when blades are being replaced.
- Never change blades or service the tool while it is still connected to the compressed air source. Always make sure the device is detached from the compressed air source when performing an inspection or servicing operation. Make sure that the motor is completely shut off and that the hoses are not pressurized.



WARNING: Vibration

Avoid exposure to vibration; it can damage the nervous system as well as hinder blood circulation in hands and arms. This may in turn cause pain in sensitive joints and possible old injuries.

- Always use sharp blades whose condition has been checked. A faulty or damaged blade must never be used for sawing and should be replaced with an intact blade. Dull, damaged, or faulty blades may intensify vibration.
- Avoid exposure to vibration. Long-term exposure to vibration may cause injuries to the user's joints and/or nervous system.



CAUTION Only professional technicians may use and test the PipeCut AIR 360 pipe saw.

The pipe saw may not be tested or serviced by persons untrained in the servicing of pneumatic tools. Servicing personnel must be authorized to test these kinds of tools and use a pneumatic system according to national, state specific, and local regulations.

PipeCut lower guard

Check lower guard for proper closing before each use. Do not operate saw if lower guard does not move freely and close instantly.

Never clamp or tie the lower guard into the open position. If saw is accidentally dropped, lower guard might be bent. Raise the lower guard and make sure it moves freely and does not touch the blade or any other part, in all depths of cut.

Check the operation and condition of the lower guard spring. If the guard and the spring are not operating properly, they must be serviced before use. Lower guard might operate sluggishly due to damaged parts, gummy deposits, or a buildup of

debris. For all sawing, the lower guard should operate automatically.

Always observe that the lower guard is covering the blade before placing saw down on bench or floor. An unprotected, coasting blade will cause the saw to walk backwards, cutting whatever is in its path. Be aware of the time it takes for the blade to stop after switch is released.

Always use blades with correct size and shape (diamond vs. round) arbor holes. Blades that do not match the mounting hardware of the saw will run unpredictably, causing loss of control.

Never use damaged or incorrect blade washers or bolts. The blade washers and bolt were specially designed for your saw, for optimum performance and safety of operation.

When blade is binding, or when interrupting a cut for any reason, release the trigger and hold the saw motionless in the material until the blade comes to a complete stop. Never attempt to remove the saw from the work or pull the saw backward while the blade is in motion or KICKBACK may occur. Investigate and take corrective actions to eliminate the cause of blade binding.

Tool use and maintenance

To keep the PipeCut AIR 360 pipe saw safe follow the following maintenance and check procedures.

- a) **Use clamps or another practical way to secure and support the workpiece to a stable platform.** Holding the work by hand or against the body is unstable and is able to lead to loss of control.
- b) **Do not force the tool.** Use the correct tool for the application. The correct tool will do the job better and safer at the rate for which the tool is designed.
- c) **Do not use the tool if the switch does not turn the tool on or off.** Any tool that cannot be controlled with the switch is dangerous and must be repaired.
- d) **Disconnect the tool from the air source before making any adjustments, changing accessories, or storing the tool.** Such preventive safety measures reduce the risk of starting the tool unintentionally.
- e) **Store the tool when it is idle out of reach of children and other untrained persons.** A tool is dangerous in the hands of untrained users.
- f) **Maintain the tool with care.** Keep a cutting tool sharp and clean. A properly maintained tool, with sharp cutting edges reduces the risk of binding and is easier to control.
- i) **When not in use, cap the pneumatic inlet and outlet couplings to prevent debris to enter the tool.** Debris can cause malfunction and increased wear of the tool.

g) **Before each use, check for misalignment or binding of moving parts, breakage of parts, and any other condition that affects the tool's operation.** If damaged, have the tool serviced before use. Many accidents are caused by poorly maintained tools. There is a risk of bursting if the tool is damaged.

d) **Always clean the blade guard's inside surfaces (Picture C / C1, page 18), if you have sawed plastic and are now sawing metal pipes.**

The warming of the metal shavings and blade from the sawing may cause the plastic to melt or smolder, possibly releasing toxic gases. Clean the blade guard after each use and pay particular attention to the functioning of the lower blade guard (Picture C / C7, page 18). The lower blade guard should move freely, and make sure that there is no debris, shavings, or sand in its mechanism's moving parts that could impair its functioning.

e) **Clean the gripper unit regularly, at least after each working day with clean compressed air.**

Lubricate the gripper's trapeze screw, transfer nuts, wheels, hinges (Picture A / A14, page 13), and ball bearings with the applicable oil. Check that there is no debris, chips, or other materials that could hinder its functioning in the gripper.

f) **Clean the blade guard's inside after each working day.** Tool blade guards can become cluttered causing bad performance, increased wear of cutting tool and overheating if debris is not cleaned out.

e) **Check the free running speed of PipeCut AIR360 regularly, at least annually.** Measurement can be taken from blade axle with appropriate RPM counter. For safety reasons, do not have the blade attached while measuring. Free running speed should not exceed the rating plate information.

Intended Use

PipeCut AIR 360 pipe saw is intended for use as a pipe fitter's tool at the job site.

PipeCut AIR 360 can only be used to cut round pipes, with a diameter of 75 mm–360 mm (3"–16")

Maximum wall thickness of plastics and cast iron 45 mm (1.8")

PipeCut AIR 360 pipe saw can be used to cut all normal pipe materials, such as steel, stainless steel, cast/ductile iron, copper, aluminum and plastic.

See the cutting depth table on page 20.

PipeCut AIR 360 pipe saw is not intended for use in industrial production.

Use pipe holders to support the pipe being cut.

Guarantee

The guarantee's terms became effective on 1 January 2017. If Exact PipeCut AIR 360 saw becomes unusable due to material or manufacturing faults during the guarantee's period of validity, we will repair the Exact PipeCut AIR 360 pipe saw or supply a new or factory-reconditioned Exact PipeCut AIR 360 saw free of charge according to our discretion.

GUARANTEE PERIOD

The Exact Tools guarantee is valid 12 months from the date of purchase.

The guarantee is valid only if:

1. a dated purchase receipt is furnished to the authorized servicing company or it is downloaded on our website in connection with the registration of the guarantee.
2. the Exact PipeCut AIR 360 saw has not been misused.
3. no attempt has been made by non- approved persons to repair the saw.
4. the Exact PipeCut AIR 360 saw has been used according to these operating, safety and servicing instructions.

NOTE:

The Exact PipeCut AIR 360 saw should be furnished to an authorized repair shop with delivery expenses paid. If the Exact PipeCut AIR 360 saw is repaired within the scope of the guarantee, the product will be returned with the delivery expenses paid. If the Exact PipeCut AIR 360 saw is not repaired within the scope of the, guarantee, the delivery expenses will be the customer's responsibility.

GUARANTEE'S LIMITATIONS:

The guarantee does not cover the following parts, services, or damages:

- Saw blades and diamond blades
- Gripper unit's wheels.
- Blade flange.
- Attachment flange.
- Pulling flange washer.
- Air motor vane's and sealings.
- Normal wear.
- Misuse or faults and damages resulting from accidents.
- Water, fire, and physical damages.
- Motor breakage or other damage caused by dirt or an unsuitable grade of oil.
- Damages resulting from the use of air whose purity level falls below its reference value.
- Damages resulting from the use of air volumes or air pressures exceeding their reference values.

As a result of continuous product development, the information in this manual may change. Changes are not announced separately.

Service

- a) Tool service must be performed only by qualified repair personnel.
- b) When servicing a tool, use only identical replacement parts. Use only original, authorized parts.
- c) Use only the lubricants supplied with the tool or specified by the manufacturer.
- d) After each service make a test cut to check the proper function of the tool. Pay attention to alignment of the cut, noise and vibration levels.

The motor's interior parts should not be washed with cleaning fluids but blown clean with air jets. Do not use solvents as lack of lubrication will cause jamming of the operational valves.

Only professionally capable technicians can test the Exact PipeCut AIR 360 pipe saw. The pipe saw cannot be tested or serviced by persons who have not been trained in the servicing of pneumatic tools. They must be authorized to test these kinds of tools and use pneumatic systems according to national, state- specific, and local regulations.

Environmental information



Separate collection.

When your Exact PipeCut AIR 360 machine is worn out, do not dispose of it with normal household waste; the product must be recycled separately. The separate collection and recycling of used products and packaging facilitates the recovery of materials, reduces environmental pollution, and decreases the demand for raw materials. Local regulations allow the delivery of households' pipe saws to municipal waste dumps or a dealer when buying a new product.

PICTURE A

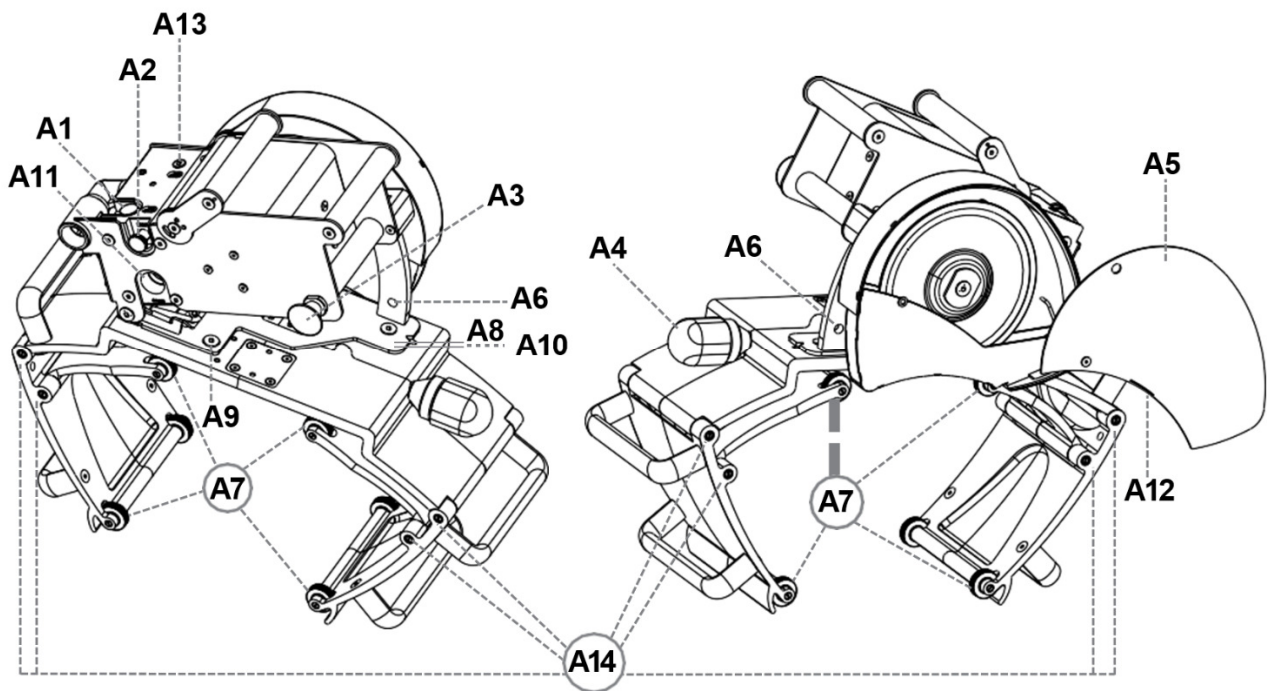

- A1 START button
- A2 STOP button (air current shutoff switch)
- A3 Locking pin
- A4 Gripper adjustment lock
- A5 Blade guard
- A6 Locking pin hole
- A7 Gripper's wheels and ball bearings
- A8 Adjustment screw
- A9 Adjustment screw
- A10 Adjustment pointer
- A11 Inlet coupling
- A12 Measuring edge
- A13 Oil tank cap
- A14 Gripper's joints

OPERATIONAL INSTRUCTIONS

Pipe saws are designed with a gripper unit that ensures the saw's secure attachment to the pipe. The saw is attached by turning the gripper adjustment lock (Picture A / A4) and by tightening it securely to the pipe. Make sure that all of the gripper's wheels turn freely and that there is no sand or debris between the joints. If debris or sand is present, the gripper must be cleaned before beginning the work.

If a fault is detected in the gripper unit's mechanism, the saw cannot be used.

BEFORE USING THE PIPE SAW, CHECK THAT:

- the sliding lower blade guard slides freely.
- the motor unit's locking mechanism functions perfectly.
- the gripper unit's wheels turn freely.
- the compressed air's pressure and out-put comply with the manual's recommendations.
- the pipe to be cut is firmly supported on both sides of the cutting point.
- the compressed air hoses have been attached properly.
- the safety wire preventing the hose's detachment from the machine is securely in place.
- you have the right type of blade, specifically designed to cut the material to be sawed, installed in the machine.
- the blade is in good condition and is tight.
- you have the proper personal protection equipment as specified in the operational safety section of this manual.
- there is enough oil in the oil tank.

NOTE: the motor will not start if there is not enough oil in the oil tank. If the oil starts to run low during the sawing, the motor will shut off and not start before the oil tank has been filled.

Start the motor by pushing the START button (Picture A / A1). Make sure that STOP button (Picture A / A2) has been pulled to its out-position. If the STOP button is at its in-position, the motor will not start. Begin sawing within 15 seconds after the motor has been turned on to avoid running the motor unloaded or at overspeed.

DETERMINATION OF PIPE'S SAWING POINT

Mark the sawing point on the pipe to be cut in a way that deducts one inch from the required measurement. The blade's point of contact with the wall of the pipe is one inch from the measuring edge in the direction of the saw's gripper unit. Always keep in mind that the measuring edge is set one inch more than, or correspondingly less than, the required measurement depending from which direction the required dimension is being calculated.

ATTACHMENT OF PIPE SAW TO PIPE

Place the pipe saw above the pipe to be sawn, ensuring that the gripper encloses the pipe to be sawn. The diameter of the pipe saw's gripper can be adjusted with the gripper adjustment lock (Picture A / 4). Place the pipe saw at the desired position by using the measuring edge part of the blade guard. (Picture A / A12). Adjust the gripper unit according to the pipe's diameter by turning the pipe saw's gripper adjustment lock (Picture A / A4) and tightening the saw against the pipe. Make sure that the compressed air hose or any other object is not caught between the gripper and the pipe to be cut. Never begin sawing if your fingers, or any other improperly placed clothes or other tools, are between the gripper and the pipe. Also remove any possible sand and/or other debris from under the gripper. Make sure that the saw travels freely. If the saw is not moving properly, detach the saw from the pipe and check the gripper's wheels and ball bearings, (Picture A / A7) cleaning and oiling them if necessary. If the saw's gripper unit has been damaged, the machine cannot be used until it is repaired.

PIERCING AND SAWING OF PIPE WALL

Make sure that all persons working near the pipe saw have the appropriate personal protection equipment.

Firmly grip the saw's operating handle (Picture D / D1, page 15) with your right hand and hold the gripper adjustment lock (Picture A / A4) with your left hand.

Pierce the pipe's wall by gently pushing the pipe saw's operating handle directly downwards with an even pressure until the blade has cut through the pipe's wall and the motor unit has locked in the sawing position. You will feel the locking when the locking pin (Picture A / A3) snaps into the slot designed for it (Picture A / A6) and moves slightly to the right.

Now that the pipe saw is locked in the sawing position and you can safely begin the pipe's circular sawing. Never feed the saw in the wrong direction.

PICTURE D (Pipe cutting)

- D1 Handle 1
- D2 Handle 2
- D3 Handle 3
- D4 Handle 4
- D5 Handle 5
- D6 Handle 6

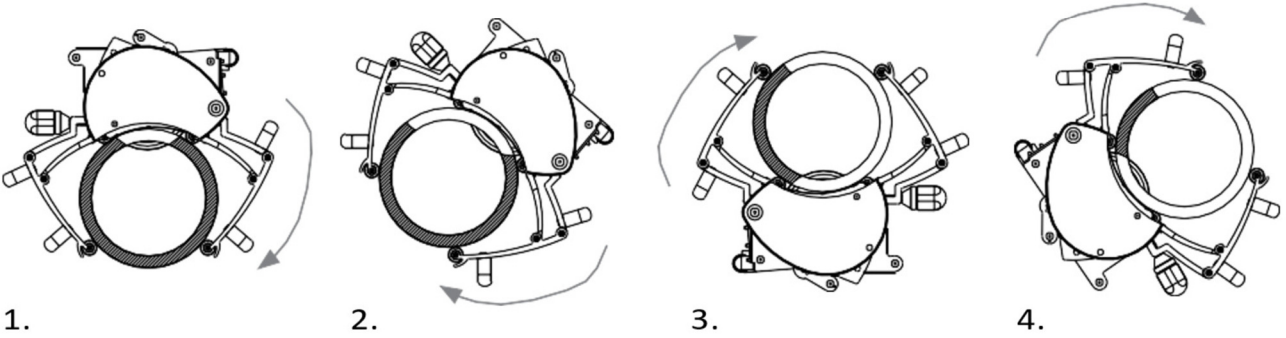
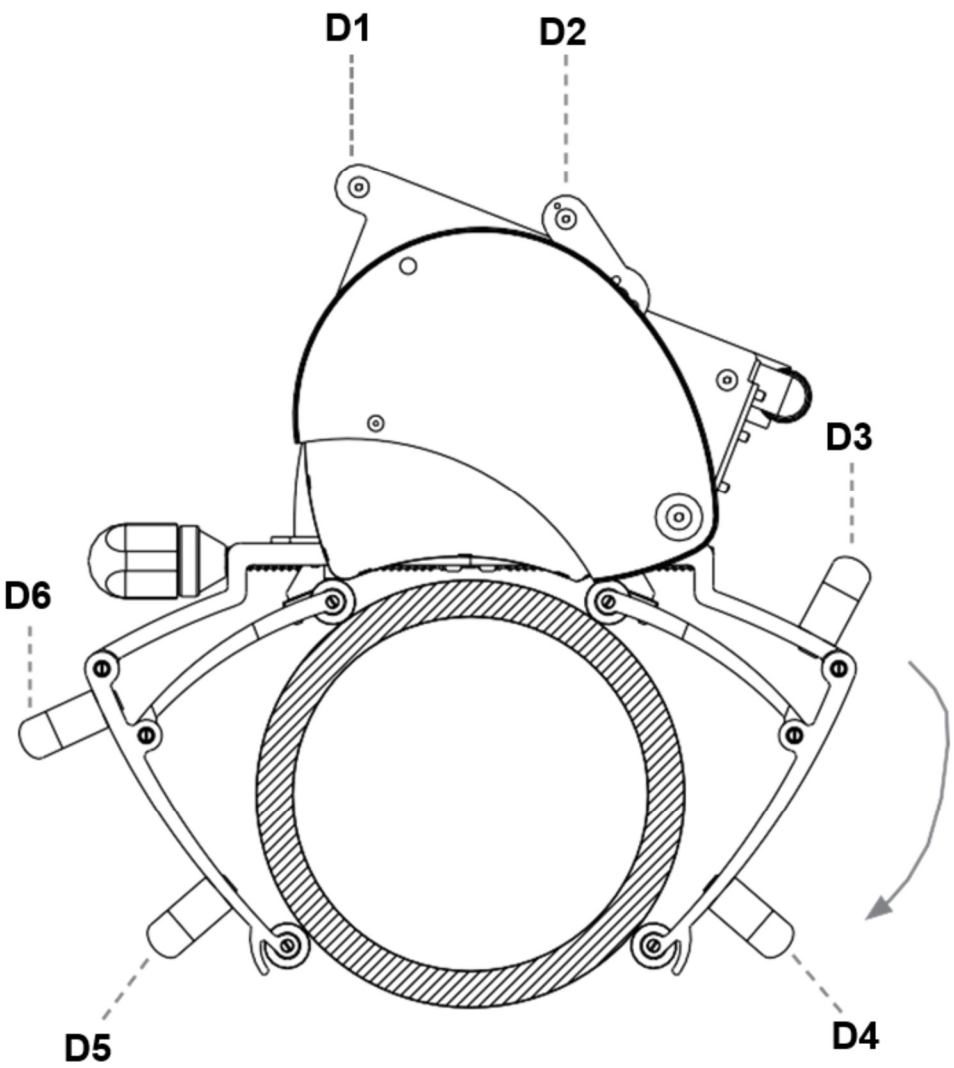

THE PIPE'S CIRCUMFERENTIAL SAWING CONSISTS OF FOUR STEPS:

1. Begin the sawing by feeding the pipe saw forward while gripping the handles (Picture D / D1 and D2) until you have sawed approximately one-fourth of the pipe's circumference.
2. Change your grip on the handles: (Picture D / D4 and D5) now the pipe saw's own weight helps the feeding motion and you can also slightly brake the feeding speed.
3. When the pipe saw is under the pipe, change the position of your grip on the handles (Picture D / D2 and D3) and pull the pipe saw forward and upwards until you have sawed approximately three-fourths of the pipe's circumference.
4. Once again change the position of your grip on the handles (Picture D / D1 and D6) and feed the pipe saw until the cutting is completed.

Release the motor unit to the upper position by pulling the locking pin (Picture A / A3, page 13) and press the STOP (Picture A / A2, page 13) button immediately to turn off the motor. Always avoid using the motor without loading.

The feeding speed is selected according to the pipe's material and wall thickness. An excessive feeding speed can damage the blade, overload the pipe saw, and cause a poor sawing result. Control the feeding speed during the entire duration of the cutting. Never completely let go of the saw while cutting.

If problems, unusual noises, or excessive vibrations occurring during the piercing or sawing process require the sawing to be interrupted before the pipe has been cut, turn off the motor by pushing the STOP button (Picture A / A2, page 13) and release the blade by pulling the locking pin out (Picture A / A3, page 13).

When the problem that caused the interruption has been clarified and fixed, resume sawing after checking that the saw or blade has not been damaged. Never start the motor when the motor unit is locked in its sawing position or when the teeth of the blade are in contact with the pipe to be sawn.

FILLING OF OIL TANK

NOTICE:

- Use only the correct type of oil specified for this purpose.
- Keep debris, sand, or shavings from passing into the oil tank. Unwanted materials in the oil tank can damage the lubrication system or the device's other precision mechanics.

Open the oil tank cap (Picture A / A13, page 13) by using the supplied hex socket key. Use appropriate effort to press the piston inside the oil tank down by using a clean stick-like tool such as a screwdriver. You will feel the downward motion of the piston when it clicks in place. Pour oil into the oil tank using a suitable dosing feeder or funnel to avoid spillage. When the oil tank is full, screw the oil tank cap firmly in place. The piston inside the oil tank will snap back to its initial position when the motor is started.

 NOTICE: The level of the oil, for example at the halfway mark, may be visible in the tank's oil level sight glass. This does not, however, indicate the actual level of the oil.

The position of the piston, also visible in the oil level sight glass, provides the only true indication of the amount of oil in the tank. When the piston has been pushed down it is no longer visible in the oil level sight glass.

UNDERWATER SAWING

If the pipe to be cut is partially or completely underwater, or it is possible that water coming from within the pipe will raise the water level at the cutting location so high that the saw will remain submerged during the cutting period, an additional hose should be used in the air exhaust opening. The length of the additional hose should enable it to reach above the water surface during the entire duration of the cutting. Connect the additional hose by threading a $\frac{3}{4}$ inch thread to the opening on the rear section of the pipe saw (Picture A / A11, page 13). Make sure that the hose cannot wave around uncontrollably, which could cause a hazardous situation.

If necessary, use a safety wire to support the additional hose, which should always be intact.

An exhaust pipe attached to the machine can detrimentally affect sawing efficiency, particularly if the pipe is long or has a small diameter. When carrying out under-water sawing, the participation of at least two workers is recommended. One worker supervises the progress of the work and is close to the compressed air shutoff valve in case a possible emergency shut-down of the machine is necessary. The other worker performs the actual sawing.

USE IN COLD CONDITIONS

 **WARNING:** Use warm safety gloves when handling the saw in cold conditions. Cold metal may cause skin injuries.

In cold conditions, note the possible development of brittleness in the material to be cut.

Check the blade screw's tightness before cutting by using the supplied open-end wrench and hex socket key.

Check before use that there is no moisture or ice inside the compressed air hose you are using. Possible excess moisture and pieces of ice may damage the hose, resulting in personal injuries or damage to the materials.

Make sure that you use oil that suits the operation of compressed air machines in cold conditions. When the temperature falls under -5°C (23°F), make sure that the pour point of the machine's lubrication oil is lower than -25°C / -13°F .

Because moisture remaining in the pipe saw's motor, lubrication system, and other channels may freeze, the pipe saw should be stored and maintained in a warm location. To remove any condensate water that has entered with the compressed air, a dry cutting should be made with the pipe saw indoors and in dry conditions. The stream of warm and dry compressed air fed through the pipe saw's motor, lubrication system, and air vents will remove possible moisture and reduce the risk of freezing.

Do not use solvent-borne de-icing fluids that could damage the lubrication system.

STORAGE

Store the pipe saw in a dry location shielded from direct sunlight. Do not store the pipe saw on weak structures or a wobbly shelf.

Make sure that the storage location can support the weight of the pipe saw. Protect the pipe saw and its parts from possible dents.

During storage, cap the pneumatic inlet and outlet couplings to prevent debris to enter the tool. Debris can cause malfunction and increased wear of the tool.

SAWING ALIGNMENT ADJUSTMENT

Open the adjustment screws (Picture A / A8 and A9, page 13) and turn the tool in the adjustment pointer (Picture A / A10, page 13) as shown in the picture. If you need sawing to go more to the left, turn the adjustment pointer the right. Tighten the two screws after adjustment

WINTERTIME USE

When the temperature falls under -5°C (23°F), make sure that the pour point of the machine's lubrication oil is lower than -25°C / -13°F

Changing blades

PICTURE C

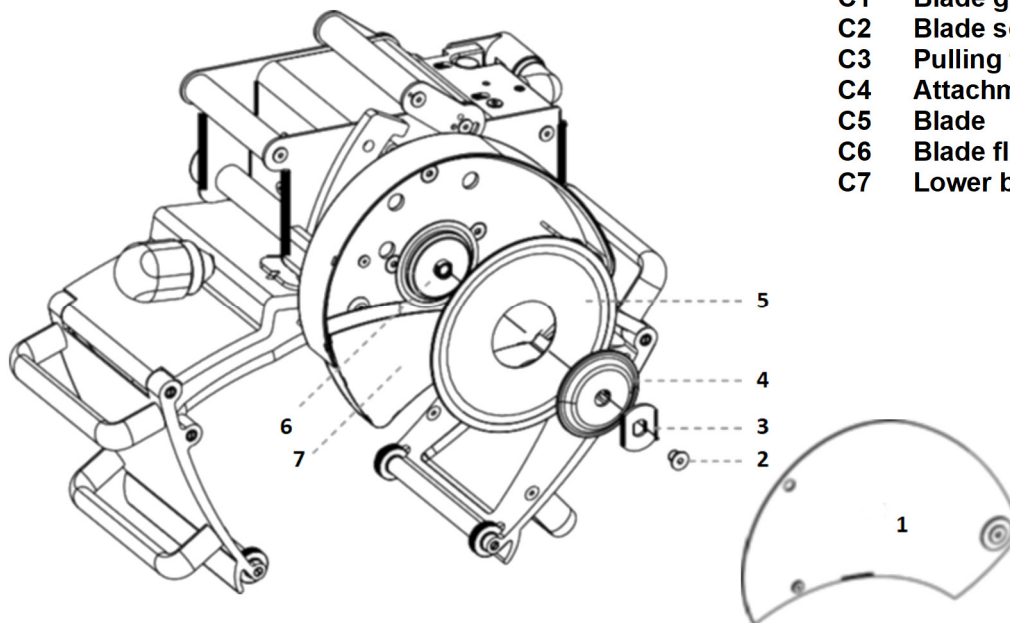

- C1 Blade guard
- C2 Blade screw
- C3 Pulling flange washer
- C4 Attachment flange
- C5 Blade
- C6 Blade flange
- C7 Lower blade guard

⚠ WARNING: Never change the blade if the machine is connected to a compressed air source or you are not sure if the motor has completely stopped.

Always use undamaged tools when changing blades. Damaged tools will not necessarily achieve the required tightness for the blade's attachment components, which may cause loosening while sawing.

⚠ WARNING: Only use blades displaying the Exact brand name:
 Exact ALU 180, Exact ALU 165
 Exact Diamond X 180, Exact Diamond X 165
 Exact Cermet X 180, Exact Cermet X 165

Do not use other manufacturers' blades. Exact Tools blades are high quality and have been designed specifically for the Exact PipeCut AIR 360 pipe saw.

⚠ NOTICE: Check the condition of the blade. Cutting with a dull blade causes extra strain on the machine and can lead to a significantly poorer sawing result. A dull or damaged blade must be immediately replaced by a new or sharpened blade. Sawing with a dull or damaged blade can cause extra sparking, detached saw teeth, and thus a hazardous situation to persons and/or materials.

Never saw with a bent or damaged blade.

The tools used to change blades are supplied with the machine. A blade can also be changed with other correctly-sized hex socket keys and open-end wrenches. PipeCut AIR 360 pipe saw's blades can be changed in job site conditions.

Open the blade guard (Picture C / C1) with the supplied hex socket key. After setting the blade guard aside, open the blade screw (Picture C / C2) with the hex socket key and open-end wrench. Use the open-end wrench as a counterforce to prevent a turning motion by setting the pulling flange washer securely in the place designed for it, after which the blade screw will open by turning the hex socket key. Use force if the screw is tight. Remove the pulling flange washer (Picture C / C3) and the attachment flange (Picture C / C4), after which you can set the blade (Picture C / C5) in place. Make sure that the blade flange located under the blade (Picture C / C6) is securely in place and that there are no shavings, debris, sand or other functionally detrimental materials between the blade flange and the newly installed blade. Also check that there are no shavings, debris, sand, or other functionally detrimental materials in the attachment flange, screws, or pulling flange washer.

If there is unwanted matter in the blade or other parts, the parts must be cleaned before their installation. When the new blade has been securely placed over the blade flange, set the attachment flange carefully over the blade, then re-attach the pulling flange washer and screw. Tighten the screw with the open-end wrench by using the pulling flange washer as a counterforce.

Theoretical maximum cutting depths

Pipe diameter DN mm/inch	Cutting depth mm/inch blade 180 mm/7"	Cutting depth mm/inch blade 165 mm/6.5"
150/6	33.7/1.35	26.2/1.03
200/8	35.8/1.40	28.3/1.11
250/10	39.0/1.55	31.5/1.24
300/12	42.3/1.70	34.8/1.37
350/14	45.0/1.80	37.5/1.47

THE EXACT PIPECUT AIR 360 MACHINE CUTS ALL KNOWN PIPE GRADES AND WITH THE FOLLOWING BLADES:

- Exact Diamond X 180 and X 165 Discs, for cutting cast iron only.
- Exact ALU 180 and 165, aluminum and all kinds of plastics.
- Exact Cermet 180 and 165, for cutting steel and stainless steel.

ATTENTION! Do not cut pipes with thicker than the above mentioned wall thickness.

ATTENTION! Check the status and condition of the blade before cutting