

exact

PipeCut V800E Ventilation System

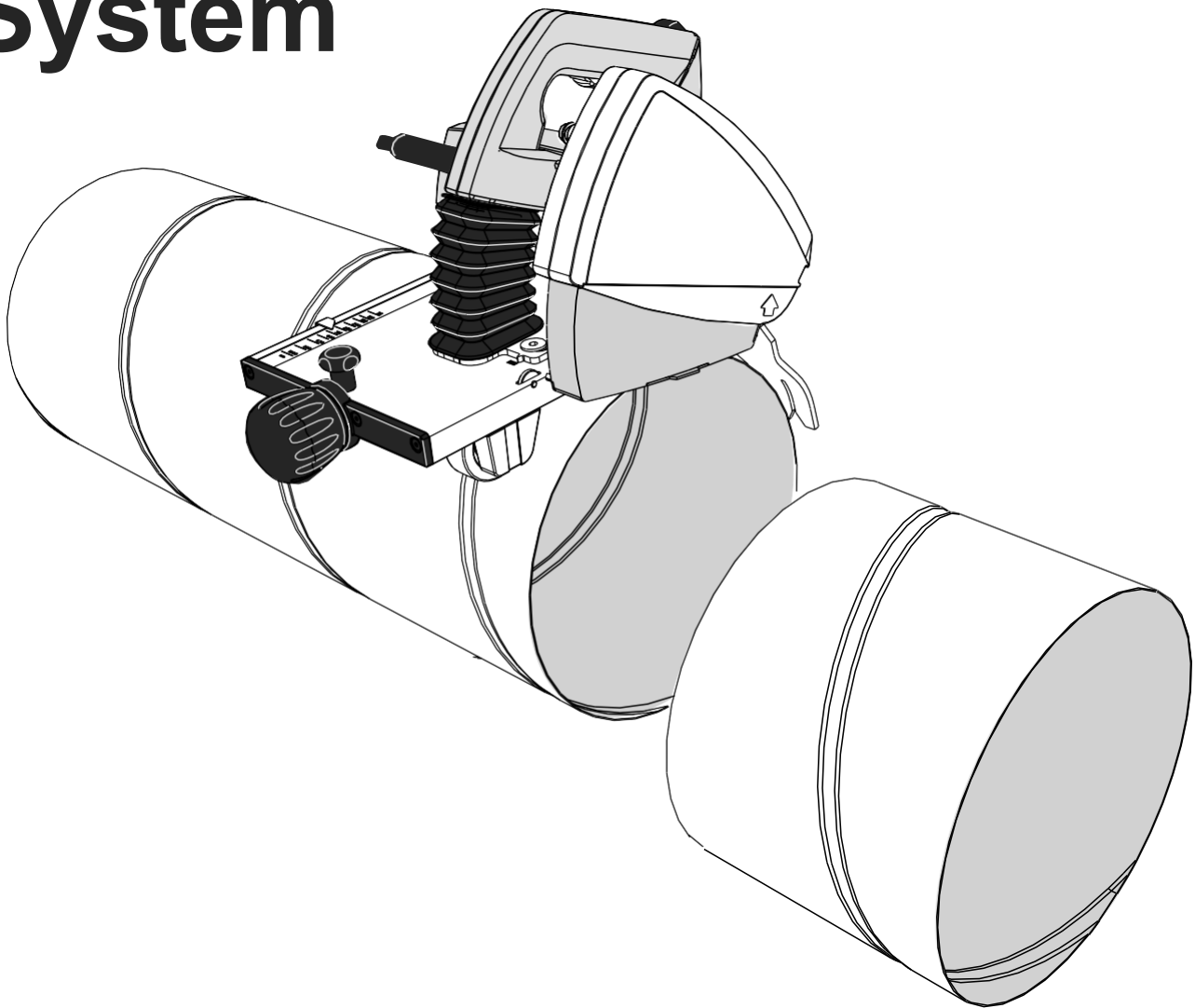

EN Operating manual

5-16

Exact PipeCut V800E

Blade information for Exact PipeCut saws

Cermet (ceramic alloy tip) saw blades are very durable special saw blades. Cermet V155 is designed especially for cutting thin sheet materials such as spiral ducts. Cermet blades can be sharpened a few times.

Pipe Support V1000

We recommend to use Exact Pipe Support V1000 for to support the pipes when using Exact Pipecut V800E pipe saw. These pipe holders are specially designed to be used with Exact Pipecut V800E pipe saw. They can be used with pipes from 3' (75 mm) up to 32' (800 mm).

Declaration of Conformity



We declare under our sole responsibility that the products described under "Technical Data" are in conformity with the following standards or standardization documents:

EN 62841-1:2015 + A11:2022, EN 62841-2-5:2014, EN 55014-1:2017 + A11:2020, EN 55014-2:1997 + A2:2008, EN 61000-3-2:2014, EN 61000-3-3:2013,

according to the technical provisions of the directives 2006/42/EC and 2014/30/EU

For more information, please contact Exact Tools at the following address.

The technical file is available at the address underneath.

The person authorized to compile the technical file:

Marko Törrönen, Chief Technology Officer, Exact Tools Oy (marko.torronen@exacttools.com)

Helsinki, 21.01.2026

A handwritten signature in black ink, appearing to read 'Sami Simula'.

Sami Simula
CEO
Exact Tools Oy
Martinkyläntie 41
FI-01720 Vantaa
Finland

A

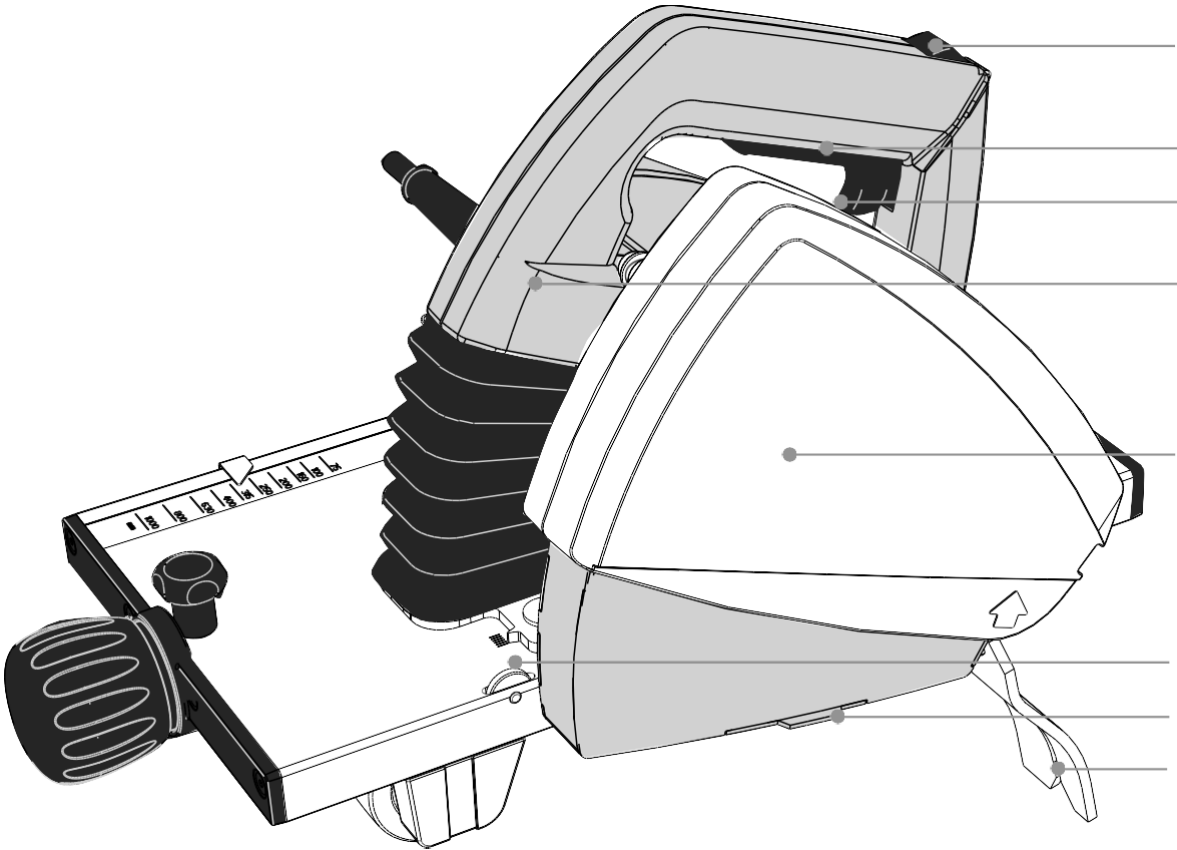

- 1.
- 2.
- 3.
- 4.
- 5.
- 6.
- 7.
- 8.

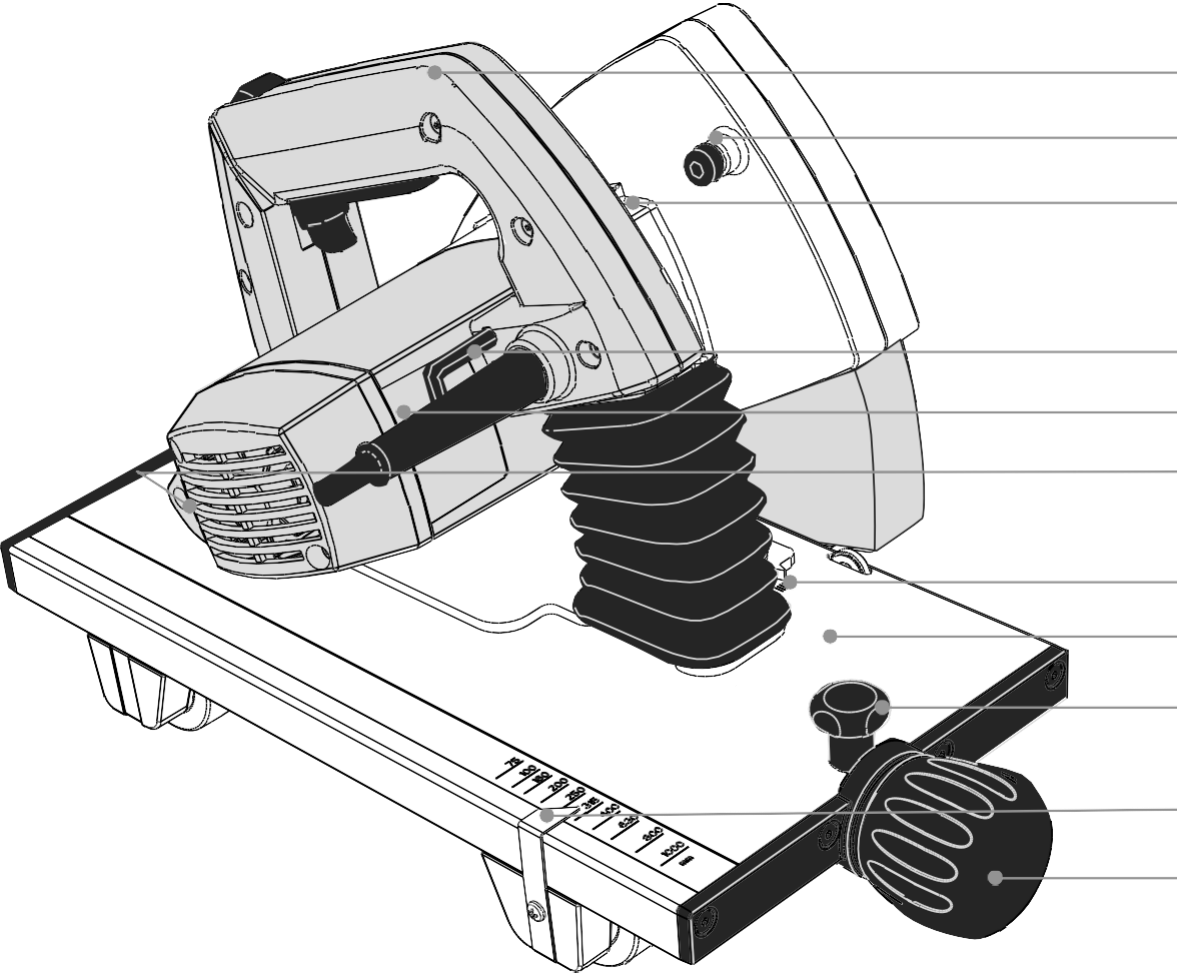

- 9.
- 10.
- 11.
- 12.
- 13.
- 14.
- 15.
- 16.
- 17.
- 18.
- 19.

Contents

exact
Pipe Cutting System

- 6. Technical data
- 6. Package contents

Safety

- 7. Safety instructions

Operation

- 10. Functional description
- 10. Product features
- 11. Before operating the tool
- 11. Connection to the mains power supply
- 11. Precise setting of the cutting point
- 11. Setting the pipe on supports
- 12. Attaching the pipe saw to the pipe
- 12. Piercing the pipe wall
- 12. Sawing around a pipe
- 13. Blade speed selector
- 13. Straightness of cut and adjusting wheel
- 14. **Installing and changing the saw blade**
- 14. **Service and maintenance instructions**
- 16. **Environment/Disposal**
- 16. **Guarantee/Guarantee conditions**
- 16. **Tips for users**

Definitions: Safety guidelines

The definitions below describe the level of severity for each signal word. Please read the manual and pay attention to these symbols.



DANGER: Indicates an imminently hazardous situation which, if not avoided, **will** result in **death or serious injury**.



WARNING: Indicates a potentially hazardous situation which, if not avoided, **could** result in **death or serious injury**.



CAUTION: Indicates a potentially hazardous situation which, if not avoided, **may** result in **minor or moderate injury**.



NOTICE: Indicates a practice **not related to personal injury** which, if not avoided, **may** result in **property damage**.



Denotes risk of electric shock.

Operating, safety, and servicing instructions

Please read this operating, safety, and servicing instructions carefully before using the pipe saw. Also store this instruction book somewhere accessible to everyone using the pipe saw. In addition to these instructions, always follow the official work, health and safety regulations. The Exact PipeCut is meant for professional use only.

Technical data

	Pipecut V800E
Voltage	230 V / 50 Hz or 120 V / 60Hz
Power	1200 W (230 V) / 9.2 A (120 V)
No-Load speed	3500 r/min
Intermittent operation	S3 25% 10min (2,5 min ON /7,5 min OFF)
Blade diameter	155 mm
Mounting bore	65 mm
Weight	6,6 kg
Range of use Ø	75 mm – 800 mm
Max. pipe wall steel	1,5 / 6 mm
Protection class	▣ / II
Spindle lock	YES
Speed preselection	YES
Constant electronic control	YES
Overload Protection	YES
Reduced starting current	YES
Vibration emission value ah	1.9 m/s ²
Uncertainty of Vibration emission value K	1.5 m/s ²
LWA (sound power)	114 dB
LpA (sound pressure)	103 dB
LpC (highest peak of sound pressure)	<130 dB

The values given are valid for nominal voltages [U] of 230/240V. For lower voltage and models for specific countries, these values can vary.

Please observe the article number on the type plate of your machine. The trade names of the individual machines may vary. Only for power tools without reduced starting current: Starting cycles generate brief voltage drops. Interference with other equipment/machines may occur in case of unfavourable mains system conditions. Malfunctions are not to be expected for system impedances below 0.36 ohm.

Noise/Vibration Information

Measured values determined according to EN60745-1:2009 + A11:210 ja EN60745-2-3:210.

Wear hearing protection!

The test was performed using Ø315 thin wall spiral duct.

The vibration emission level given in this information sheet has been measured in accordance with a standardised test given in EN 60745 and may be used to compare one tool with another. It may be used for a preliminary assessment of exposure.

! **WARNING:** The declared vibration emission level represents the main applications of the tool. However if the tool is used for different applications, with different accessories or poorly maintained, the vibration emission may differ. This may significantly increase the exposure level over the total working period. An estimation of the level of exposure to vibration should also take into account the times when the tool is switched off or when it is running but not actually doing the job. This may significantly reduce the exposure level over the total working period.

Identify additional safety measures to protect the operator from the effects of vibration such as: maintain the tool and the accessories, keep the hands warm, organisation of work patterns.

Exact PipeCut V800E pipe saw

Package contents:

Please check the package contains the following items (page 4):

1. Pipe cutting System case
2. Exact PipeCut V800E pipe saw
3. Operating instructions
4. Allen key 5 mm fixed to the handle
5. Cermet blade 155 x 65 fitted on the machine

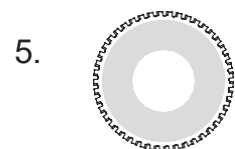
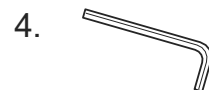
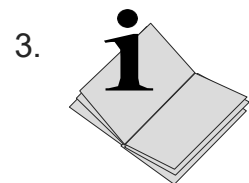
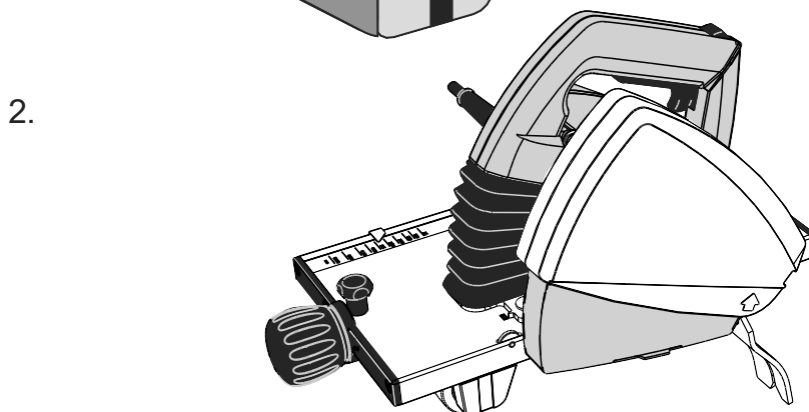
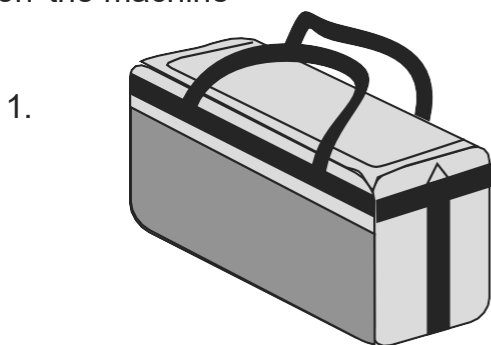

General power tool safety warnings



WARNING: Read all safety warnings and all instructions.

Failure to follow the warnings and instructions may result in electric shock, fire and/or serious injury

Save all warnings and instructions for future reference.

The term “power tool” in the warnings refers to your mains-operated (corded) power tool or batteryoperated (cordless) power tool.

1) Work area safety

- a) **Keep work area clean and well lit.** Cluttered or dark areas invite accidents.
- b) **Do not operate power tools in explosive atmospheres, such as in the presence of flammable liquids, gases or dust.** Power tools create sparks which may ignite the dust or fumes.
- c) **Keep children and bystanders away while operating a power tool.** Distractions can cause you to lose control.

2) Electrical safety

- a) **Power tool plugs must match the outlet. Never modify the plug in any way. Do not use any adapter plugs with earthed (grounded) power tools.** Unmodified plugs and matching outlets will reduce risk of electric shock.
- b) **Avoid body contact with earthed or grounded surfaces, such as pipes, radiators, ranges and refrigerators.** There is an increased risk of electric shock if your body is earthed or grounded.
- c) **Do not expose power tools to rain or wet conditions.** Water entering a power tool will increase the risk of electric shock.
- d) **Do not abuse the cord. Never use the cord for carrying, pulling or unplugging the power tool. Keep cord away from heat, oil, sharp edges and moving parts.** Damaged or entangled cords increase the risk of electric shock.
- e) **When operating a power tool outdoors, use an extension cord suitable for outdoor use.** Use of a cord suitable for outdoor use reduces the risk of electric shock.
- f) **If operating a power tool in a damp location is unavoidable, use a residual current device (RCD) protected supply.** Use of an RCD reduces the risk of electric shock.

3) Personal safety

- a) **Stay alert, watch what you are doing and use common sense when operating a power tool. Do not use a power tool while you are tired or under the influence of drugs, alcohol or medication.** A moment of inattention while operating power tools may result in serious personal injury.

- b) **Use personal protective equipment. Always wear eye protection.** Protective equipment such as dust mask, non-skid safety shoes, hard hat, or hearing protection used for appropriate conditions will reduce personal injuries.
 - c) **Prevent unintentional starting. Ensure the switch is in the off-position before connecting to power source, picking up or carrying the tool.** Carrying power tools with your finger on the switch or energising power tools that have the switch on invites accidents.
 - d) **Remove any adjusting key or wrench before turning the power tool on.** A wrench or a key left attached to a rotating part of the power tool may result in personal injury.
 - e) **Do not overreach. Keep proper footing and balance at all times.** This enables better control of the power tool in unexpected situations.
 - f) **Dress properly. Do not wear loose clothing or jewellery. Keep your hair, clothing and gloves away from moving parts.** Loose clothes, jewellery or long hair can be caught in moving parts.
 - g) **If devices are provided for the connection of dust extraction and collection facilities, ensure these are connected and properly used.** Use of dust collection can reduce dust-related hazards.
 - h) **Do not overreach. Keep proper footing and balance at all times.** This enables better control of the power tool in unexpected situations.
 - i) **Dress properly. Do not wear loose clothing or jewellery. Keep your hair, clothing and gloves away from moving parts.** Loose clothes, jewellery or long hair can be caught in moving parts.
 - j) **If devices are provided for the connection of dust extraction and collection facilities, ensure these are connected and properly used.** Use of dust collection can reduce dust-related hazards.
- ### 4) Power tool use and care
- a) **Do not force the power tool. Use the correct power tool for your application.** The correct power tool will do the job better and safer at the rate for which it was designed.
 - b) **Do not use the power tool if the switch does not turn it on and off.** Any power tool that cannot be controlled with the switch is dangerous and must be repaired.
 - c) **Disconnect the plug from the power source from the power tool before making any adjustments, changing accessories, or storing power tools.** Such preventive safety measures reduce the risk of starting the power tool accidentally.

- d) **Store idle power tools out of the reach of children and do not allow persons unfamiliar operate the power tool.** Power tools are dangerous in the hands of untrained users.
- e) **Maintain power tools. Check for misalignment or binding of moving parts, breakage of parts and any other condition that may affect the power tool's operation. If damaged, have the power tool repaired before use.** Many accidents are caused by poorly maintained power tools.
- f) **Keep cutting tools sharp and clean.** Properly maintained cutting tools with sharp cutting edges are less likely to bind and are easier to control.
- g) **Use the power tool, accessories and tool bits etc. in accordance with these instructions, taking into account the working conditions and the work to be performed.** Use of the power tool for operations different from those intended could result in a hazardous situation.

5. Service

- a) **Have your power tool serviced by a qualified repair person using only identical replacement parts.** This will ensure that the safety of the power tool is maintained.

Safety warnings for circular saws

- a)  **DANGER: Keep hands away from cutting area and the blade. Keep your second hand on motor housing.**
If both hands are holding the saw, they cannot be cut by the blade.
- b) **Do not reach underneath the workpiece.** The guard cannot protect you from the blade below the workpiece.
- c) **Never hold the workpiece being cut in your hands or across your leg. Secure the workpiece to a stable platform.** It is important to support the work properly to minimize body exposure, blade binding, or loss of control.
- d) **Hold the power tool only by the insulated gripping surfaces when performing an operation where the cutting tool may contact hidden wiring or its own cord.** Contact with a "live" wire will also make exposed metal parts of the power tool "live" and shock the operator.
- e) **Always use blades with correct size and shape (diamond versus round) of arbour holes.** Blades that do not match the mounting hardware of the saw will run eccentrically, causing loss of control.
- f) **Never use damaged or incorrect blade washers or bolt.** The blade washers and bolt were specially designed for your saw, for optimum performance and safety of operation.
- g) **When blade is binding, or when interrupting a cut for any reason, release the trigger and hold the saw motionless in the material until the blade comes to a complete stop. Never attempt to remove the saw from the work or pull the saw backward while the blade is in motion.** Investigate and take corrective actions to eliminate the cause of blade binding.
- h) **When restarting a saw in the workpiece, centre the saw blade in the kerf and check that saw teeth are not engaged into the material.** If saw blade is binding, it may walk up from the workpiece as the saw is restarted.
- i) **Do not use dull or damaged blades.** Unsharpened or improperly set blades produce narrow kerf causing excessive friction and blade binding.
- j) **Use extra caution when making a "plunge cut" into existing walls or other blind areas.** The protruding blade may cut objects that can cause kickback.
- k) **Check lower guard for proper closing before each use. Do not operate the saw if lower guard does not move freely and close instantly. Never clamp or tie the lower guard into the open position.** If saw is accidentally dropped, lower guard may be bent. Raise the lower guard with the retracting handle and make sure it moves freely and does not touch the blade or any other part, in all angles and depths of cut.
- l) **Check the operation of the lower guard. If the guard and the spring are not operating properly, they must be serviced before use.** Lower guard may operate sluggishly due to damaged parts, gummy deposits, or a build-up of debris. m) Do not reach into the saw dust ejector with your hands. They could be injured by rotating parts.
- n) **Do not work overhead with the saw.** In this manner you do not have sufficient control over the power tool.
- o) **Do not operate the power tool stationary.** It is not designed for operation with a saw table.
- p) **Do not use high speed steel (HSS) saw blades.** Such saw blades can easily break.
- q) **When working with the machine, always hold it firmly with both hands and provide for a secure stance.** The power tool is guided more secure with both hands.

- r) **Secure the workpiece.** A workpiece supported by pipe holders is held more secure than by hand.
- s) **Always wait until the machine has come to a complete stop before placing it down.** The tool insert can jam and lead to loss of control over the power tool.
- t) **Never use the machine with a damaged cable. Do not touch the damaged cable and pull the mains plug when the cable is damaged while working.** Damaged cables increase the risk of an electric shock.

Additional specific safety rules

The pipe saw must never be used in the following cases, if:

- There is water or another liquid, explosive gases or poisonous chemicals inside the pipe to be cut.
- The power switch is faulty.
- The power cable is faulty,
- The blade is bent.
- The blade is blunt or in poor condition.
- The plastic components are cracked or have parts missing.
- The gripper unit is not properly tightened around the pipe or if it is warped.
- The blade guard cover or moving blade guard has been damaged or removed from the machine.
- The locking mechanisms do not work properly (UNLOCK-button).
- The pipe saw has become wet.

When using the pipe saw, the following factors must always be taken into consideration:

- Support tubes to minimise the risk of blade pinching.
- Ensure that the pipe to be cut is empty.
- Ensure that the blade is correctly installed.
- Ensure that the diameter and thickness of the blade are suitable for the pipe saw and that the blade is suitable for the rpm-range of the machine.
- Never use sideways force to stop the blade, always allow the blade to stop freely.
- Check the attachments of the blade guards.
- Never use excessive force when using the pipe saw.
- Never use the pipe saw to lift the pipe while it is still attached to the pipe.
- Avoid overloading the electric motor.
- Always follow the safety and operating instructions and current regulations.

Functional Description



Read all safety warnings and all instructions. Failure to follow the warnings and instructions may result in electric shock, fire and/or serious injury.

Intended Use

PipeCut V800E:

The Exact Pipe Cut V800E is intended for professional use at any kind of construction sites. The Exact Pipe Cut V800E is designed to be used only for thin walled ventilation ducts with a diameter of 75 mm (3") - 800 mm (32"). The maximum wall thickness that the Exact Pipe Cut V800E can cut through is 0,08" (1,5 mm). With a spiral ventilation duct the maximum thickness of the seam that the Exact Pipe Cut V800 can cut through is 6 mm (0,24"). With the Exact PipeCut V800E you can cut ducts made from the following materials: galvanised steel, stainless steel, aluminium and all kinds of plastic. PipeCut V800E pipe saw is intended for short, intermittent use. The machine may be loaded for 2,5 minutes during a 10-minute period (S3 25 %). PipeCut V800E pipe saw is not intended for use in industrial production.

Figure A

1. UNLOCK button
2. Power switch
3. Power-switch locking lever
4. Motor unit
5. Blade-guard cover
6. Straight adjustment screw
7. Edge of moving blade-guard
8. Sight
9. Operating handle
10. Blade-guard screw
11. Spindle-lock button
12. Allen key
13. Rating-plate
14. Blade speed selector
15. Straight adjustment screw
16. Steering unit
17. Safe for the steering unit
18. Steering unit indicator
19. The knob for the steering unit

Exact PipeCut V800E pipe saw operating instructions



Before use

Check that the motor unit is in the upright position so that the yellow mark on the unlock button is visible.

Check that the blade is suitable for the material of the duct that is intended to be cut.

Check that the blade is correctly in place and that it is in good condition.

Check that the guide wheels are rotating.

Check that the support wheels are rotating.

Check that the lower blade guard is moving correctly up and down.

Check that the duct intended to be cut is empty.

Connecting the Exact Pipe Cut V800E to the main power supply

Ensure that the mains voltage is the same as indicated on the rating plate (**Figure A/13**)

Connect the Exact Pipe Cut V800E to the power outlet only after having checked these operating instructions.

Setting and marking the cutting point

Mark the cutting point but remember that you have to cut the duct so that you approach the duct seam towards the closed side of it (**Figure C**). One mark is enough. You do not need to mark all the way around the duct.

Setting the supports for the duct to be cut

The supports for the duct are not delivered with the Exact Pipe Cut V800E but they are recommended accessories. The supports maximise safety and optimise the cutting result. They also reduce the size of the required space for cutting the duct. The cutting should always be done on a flat surface.

Place the duct on three supports so that the middle support is directly beneath where the duct is intended to be cut (**Figure B**). Make sure that all of the supports are in contact with the duct. Proper arrangements prevent the saw blade from jamming in the duct in the final stage of the cutting process.

In case you are not using the supports you need to do the following. Make sure that there is enough space for the duct to rotate a full circle. Place the Exact Pipe Cut V800E so that the electric cord is hanging in front of the duct from where you are standing (**Figure C**). Also make sure that there is enough loose cord to ensure free movement for the duct. If necessary, use a suitable extension cord.

To start sawing

Open the safety screw (**Figure D1**) and adjust the wheel pairs in the Pipe Cut steering device according to the diameter of the duct by rotating the adjustment knob on the back of the Pipe Cut (**Fig. D2**)

Fig B

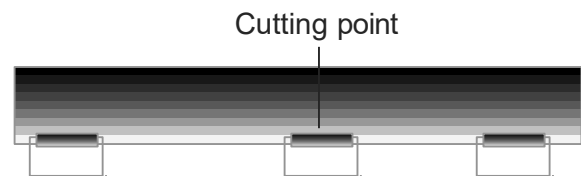

Fig C

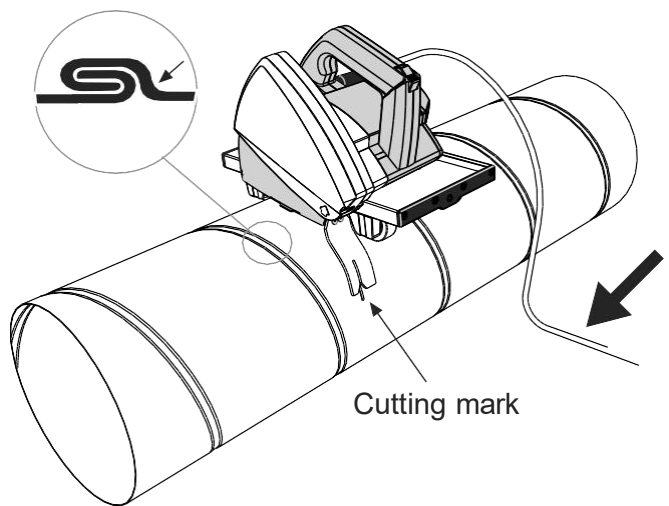
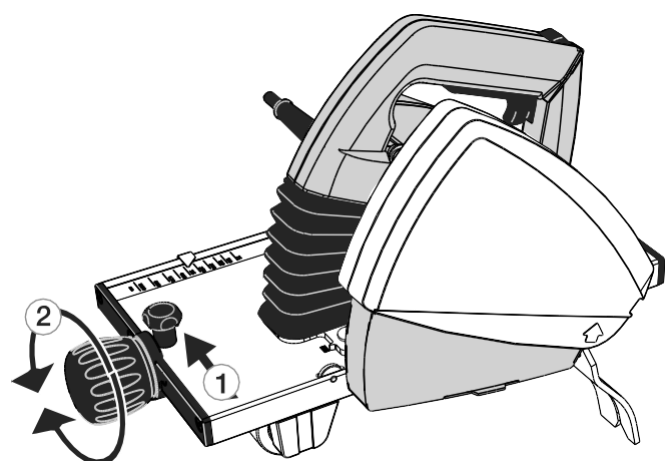

Fig D



If you follow the scale of the Pipe Cut the cutting depth is normally 10 - 15 mm as the Pipe Cut locks into the correct sawing position. Finally lock the adjustment with the safety screw so that the adjusted position does not alter during sawing.

Position the PipeCut V800E horizontally on top of the duct so that the sight of the PipeCut V800E is placed on the cutting point (**Fig E**). Hold the duct in place and ensure that the PipeCut V800E moves freely in the direction the duct is fed. To ensure safety the PipeCut V800E leads should be to the left and front of the duct. The PipeCut V800E is now ready for use.

The scale on the Pipe Cut indicating duct diameters is approximate. If the thickness of the duct wall intended to be sawn is exceptionally thin or the length of the duct is short, the weight of the Pipe Cut might flatten the duct so the diameter is enlarged. The wheel pairs must then be adjusted further apart from each other. This will ensure sufficient cutting depth for the blade.

Piercing the duct wall

Strive to keep the Pipe Cut in a horizontal position on top of the duct during the entire sawing process. Take a firm hold of the operating handle with your right hand, start the motor by releasing the locking lever on the power switch (**Fig. F/1**) and push the power switch all the way down (**Fig. F/2**). Before starting to saw wait until the blade reaches full speed. Pierce the duct wall by pressing the operating handle down slowly until the blade has cut through the duct wall (at this stage the pipe must not rotate) When the UNLOCK button is locked, i.e. the yellow mark disappears (**Fig. G**), the Pipe Cut is locked and you can safely start sawing around the duct.

Sawing around the pipe

Start sawing by rotating the pipe with your left hand towards yourself (**Fig. H**) and keep the pipe saw stable and in a horizontal position in relation to the duct (**Fig. J**). Continue sawing by rotating the duct calmly and at the most even speed possible towards yourself until the duct is cut off. If you are not using the PipeHolders the pipe will roll backwards while cutting. However, reduce sawing speed as soon as you reach the duct seam.

Fig E

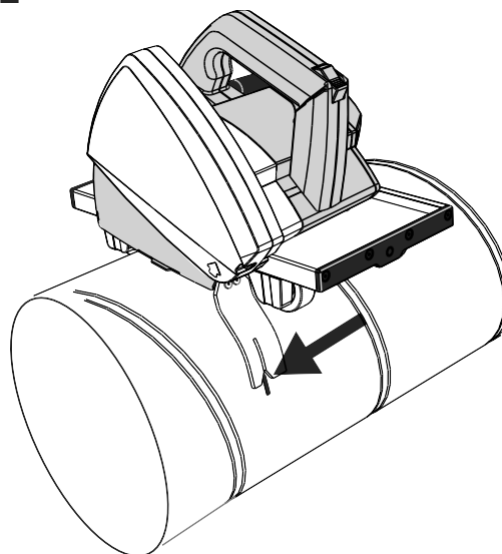

Fig F

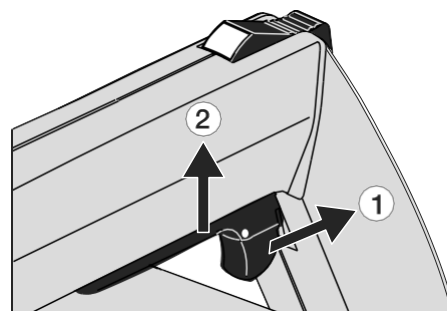

Fig G

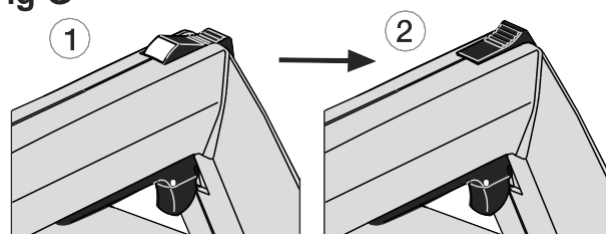
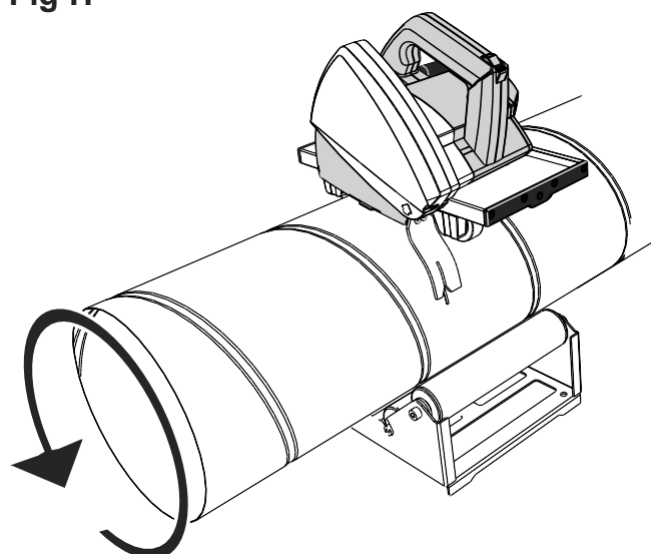

Fig H



The saw can also be steered manually if the sight does not coincide with the starting point of the cut. Follow the sight of the Pipe Cut with your eye until you see the starting point of the cut, turn the saw at a gentle angle towards the initial cut until the duct is cut off (**Fig. K**) (Tip: If the duct is not cut through clean the resulting batten can be snipped off with a pair of plate shears.)

Because the duct has a spiral seam, the rotation of it creates an illusion of the pipe moving in relation to the pipe saw. Anyway, if the pipe saw is adjusted correctly to go straight, the wheels will steer the cut straight.

When the duct is cut off, push the UNLOCK button forward until the yellow mark is visible and the locking is released (**Fig. L**). Now raise the motor unit to starting position. Release the power switch. Ensure finally that the moving lower blade guard is lowered into safety position (**Fig. M**).

Use correct feeding speed for the pipe material and the thickness of the pipe wall. Too high speed can damage the blade, overload the pipe saw and give a poor sawing result. Slow down the feeding speed once you reach the seam.

There shouldn't be any problems during piercing or sawing, abnormal sounds or vibrations due to which you have to interrupt sawing before the pipe is cut through, then release the blade by pushing the UNLOCK button forward until the UNLOCK button is released and lift the motor unit up. Once the problem is cleared, start sawing again.

Never start the motor, when the motor unit is locked in the sawing position or teeth of the blade contact the duct to be sawn.

Blade speed selector

There is a blade speed selector in the V800E. A suitable blade speed is selected, determined by the material to be sawed. There is also an automatic overload protection in the regulator.

The electronics circuit limits the current and stops the motor. When the motor stops due to overload, the red light on the pipe cutter is turned on. The pipe cutter must cool down while the electronics dissipates the internal temperature. The motor will not start (even the red light turned off) until the switch is released and pressed once more time or plug disconnect and reconnect. The red light indicates to the user that the machine was overloaded.

The indicator light in question turns on for a moment every time the motor is started. This is normal and does not require any actions.

Straightness of the cut and the adjustment feature

Sometimes the cut does not meet the starting point (**Fig N**). The cut is affected by many factors, e.g. the size of the duct, the material, the wall thickness, the quality of the duct's surface, the roundness, welded seams, blade condition, feed rate, the operator's experience. The cutting result may vary and especially so with larger ducts where it can be hard to reach the starting point.

Fig J

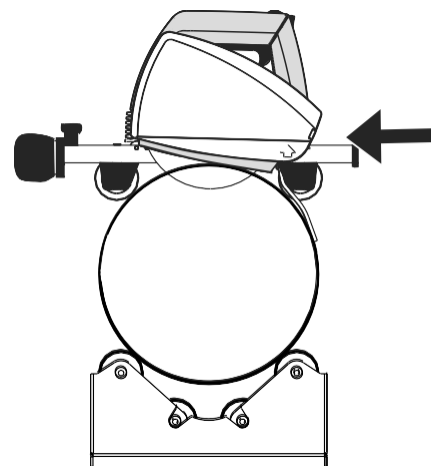

Fig K

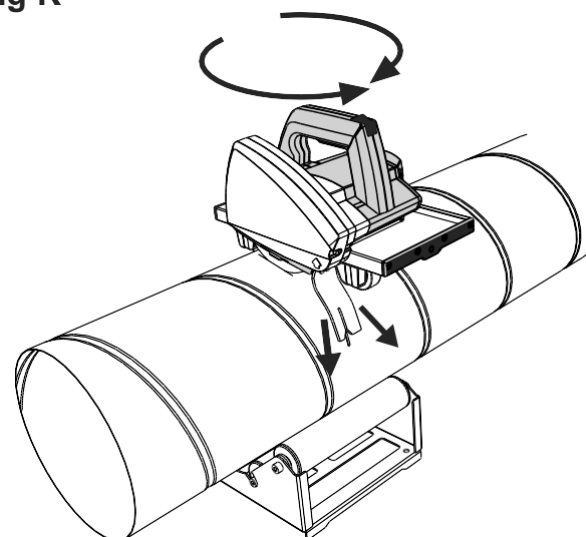

Fig L

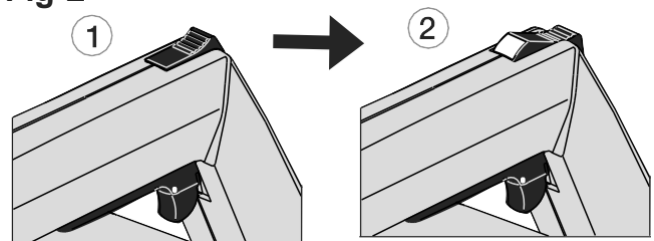
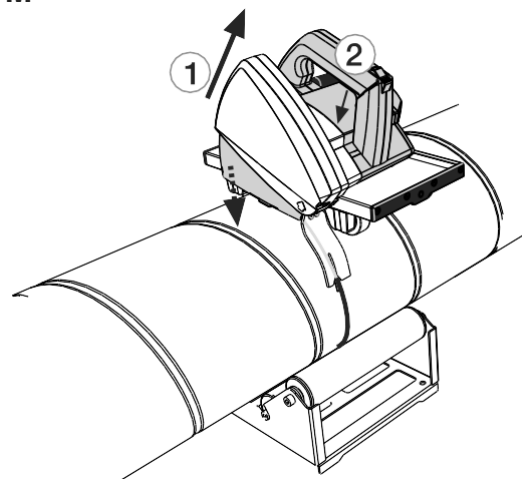

Fig M



There is a feature in the steering device of the Exact Pipe Cut V800E (**Fig.A/6**) which, if needed, can improve the sawing result and facilitate to reach the starting point.

Loosen the locking screw (**Fig.O/1**) with the M5 allen key that is attached to the handle of the pipe saw. There is an adjustment wheel on the right hand side of the steering device (**Fig.O/2**). Turn the wheel with your finger either clockwise or anti clockwise. The direction depends on the direction of the misalignment. This adjustment turns the entire motor unit in relation to the steering device. There is also an arrow and a dial on the steering device (**Fig.O/3**). These will help to gauge the extent of the adjustment. Adjust the motor unit to the desired direction to correct the sawn alignment error. The arrow indicator must move to the direction of the error. The extent of the adjustment depends on the extent of the error, duct diameter as well as the strength and material of the duct wall. Tighten the locking screw after the adjustment.

Fig N

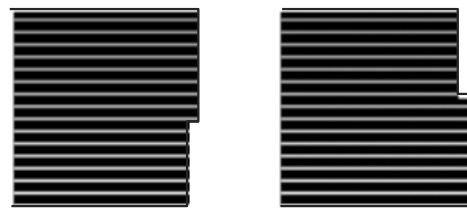
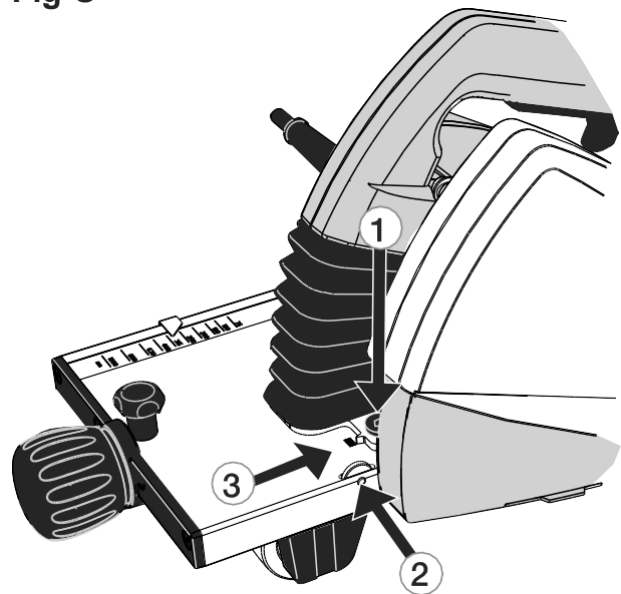

Fig O



Installing and changing the saw blade

! WARNING: To reduce the risk of injury, turn unit off and disconnect it from power source before installing and removing accessories, before adjusting or when making repairs. An accidental start-up can cause injury. Remove the power plug from the socket. Check that the motor unit is locked in the upper position.

Remove the blade guard cover (**Fig. P/1**) by opening the screw (**Fig. P/2**). Press the spindle-lock button (**Fig. A/11**) and simultaneously rotate the blade by hand until the spindle-lock button drops a further distance of about 4 mm. Now the rotation of the blade is prevented. Use the blade key to open the blade attachment bolt. Remove the blade screw (**Fig. P/3**), the washer (**Fig.P/4**), the blade flange disc (**Fig. P/5**), and the blade (**Fig. P/6**).

Before installing a new blade, check that both blade flange discs are clean. Place a new or sharpened blade on the back flange disc (**Fig. P/7**), so that the marked side of the blade is facing outwards and the arrows on the blade are facing in the same direction as the rotation direction markings on the inside of the blade case. Ensure that the new blade goes right to the bottom in the back flange disc. Put the blade flange disc, the washer, and the securing bolt back in place. Press the spindle lock button and tighten the blade securing bolt. Put the blade guard cover back in place and tighten the screw.

Fig P

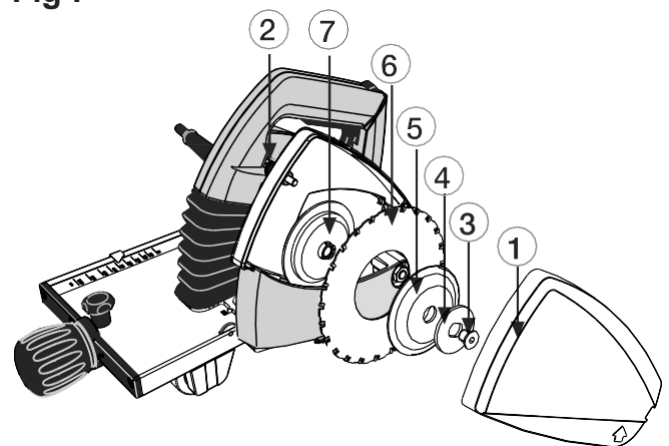

Maintenance and servicing instructions

Remove the power plug from the socket before servicing or cleaning the pipe saw. All maintenance operations carried out on the pipe saw's electrical components must be carried out at an approved service agency.

Blade

Check the condition of the blade. Replace a bent, blunt, or otherwise damaged blade with a new one. Using a blunt blade can overload the pipe saw's electric motor. When you notice that the blade is blunt, do not continue sawing with it, as the blade may become so badly damaged that it will not be worth sharpening. A blade in sufficiently good condition can be sharpened a few times by a professional sharpening company.

Steering unit

Clean the steering unit regularly with compressed air. Lubricate the steering unit's wheel axles and its joints. Also clean and lubricate the steering unit's trapezoidal screw and the two worm screws on it.

Blade guard

Make it a rule to clean the blade guard regularly, and pay special attention to keep the moving blade guard movement from becoming hampered. Lubricate the axis of the moving blade guard regularly.

Motor

Keep the motors cooling vents clean.

Plastic parts

Clean the plastic parts with a soft rag. Only use mild detergents. Do not use solvents or other strong detergents as they may damage the plastic parts and paint surfaces.



Power cable

Check the condition of the power cable regularly. A faulty power cable should always be replaced at an approved service agency.

Correct use and regular servicing and cleaning will ensure the continued operation of the pipe saw.

Environment



Separate collection. This product must not be disposed of with normal household waste. When your Exact PipeCut machine is worn out, do not dispose of it with normal household waste. This product must be recycled separately. Separate recycling of used products and packaging facilitate recycling and recovery of materials. Reusing of recycled materials helps prevent pollution of environment. According to local regulations it is possible to deliver household appliances to municipal rubbish depositories or to the dealer when buying a new product.

Guarantee

Warranty terms valid from 01.01.2015

If the Exact PipeCut Saw becomes unusable due to material or manufacturing defects within the Warranty Term at our discretion we will repair the Exact PipeCut Saw or supply an entirely new or factory reconditioned Exact PipeCut Saw at no charge.

Warranty Term / *Extended Warranty Term

The Exact Tools Warranty Term is for 12 months from date of purchase.

The Warranty is only valid if:

- 1.) Copy of a dated purchase receipt is returned to the Authorized Warranty Repair Center or has been uploaded to our website at the time of warranty registration.
- 2.) The Exact PipeCut Saw has not been misused.
- 3.) No attempt has been made by non-approved persons to repair the saw.
- 4.) The Exact PipeCut Saw has been used in accordance with the operating, safety, and servicing instructions provide in the manual.
- 5.) The Exact PipeCut Saw has been delivered to an Authorized Warranty Repair Center within the term of the warranty.

Note: The Exact PipeCut Saw is to be shipped to the Authorized Warranty Repair Center freight prepaid. If the Exact PipeCut Saw is repaired under Warranty the return shipment will be made freight prepaid. If the Exact PipeCut Saw is not repaired under Warranty the return shipment will be made freight collect.

Please Note: The following items or services are excluded from Warranty claims:

- Saw Blades
- Overload Protection Fuse
- Carbon Brushes
- Gripping Unit Wheels
- Blade Flange
- Attachment Flange
- Pulling Flange Washer
- Normal Wear and Tear
- Errors Due to Misuse or Accident
- Water, Fire and Physical Damage
- Power Cords
- Adjustment of Adjustment Wheel

Due to continuous product development, the information in this instruction book may change. We do not give separate notification of changes.

Tips for using Exact PipeCut saws

Diamond blade should only be used for cutting cast iron pipe. It is not recommended to cut cast iron with TCT or Cermet blades.

Clean the inside of the blade guards after cutting plastic pipe.

Smaller pipe is easily cut by rotating the pipe by hand either on a table or on the floor. Please note: rotate pipe towards you when rotating by hand and be careful not to rotate too fast.

Check the condition of the blade regularly.

The cutting procedure is divided into two stages; first saw through the pipe wall, then complete the cut by sawing around it.

Do not overload the saw by cutting continuously. The saw will be overheated, and the metal parts can become burning hot. This will also damage the motor and the blade. The rule is 2.5 minutes in use and 7.5 minutes rest.

Keep the feeding speed constant. This will extend the lifetime of the blade. For example cutting time for a steel pipe diameter of 6" (170mm), and a wall thickness of 1/5" (5mm), is 15-20 seconds, and for a cast-iron pipe diameter of 4" (110mm), with a wall thickness of 1/6" (4mm) is 20 to 25 seconds.

Always keep the motor unit in the upright position. The yellow mark of the unlock button is then visible. Never place the Pipe Cut Saw on the pipe in the locked / cutting position.

Factors that affect the lifetime of the saw blade:

- material of the pipe
- correct blade type for material being cut
- correct motor speed setting (model V800E)
- wall thickness of the pipe
- feeding speed
- smoothness of the pipe
- user's general skills
- cleanness of the pipe
- rust on the pipe
- welded seam in the pipe
- blade speed

Factors that affect the straightness of the cut:

- condition of the saw blade
- wall thickness of the pipe
- feeding speed
- smoothness of the feed
- user's general skills
- cleanness of the pipe
- roundness of the pipe
- gripper unit too loose or too tight
- blade assembled too tight

Please see more information at our website

www.exacttools.com

exact
Pipe Cutting System

Exact Tools Oy
Martinkylantie 41
01720 Vantaa
Finland
Tel +358 9 4366750
exact@exacttools.com
www.exacttools.com