

exact

EN Operating Instructions

PipeCut 360 Pro Series 2.0 PipeCut 460 Pro Series 2.0

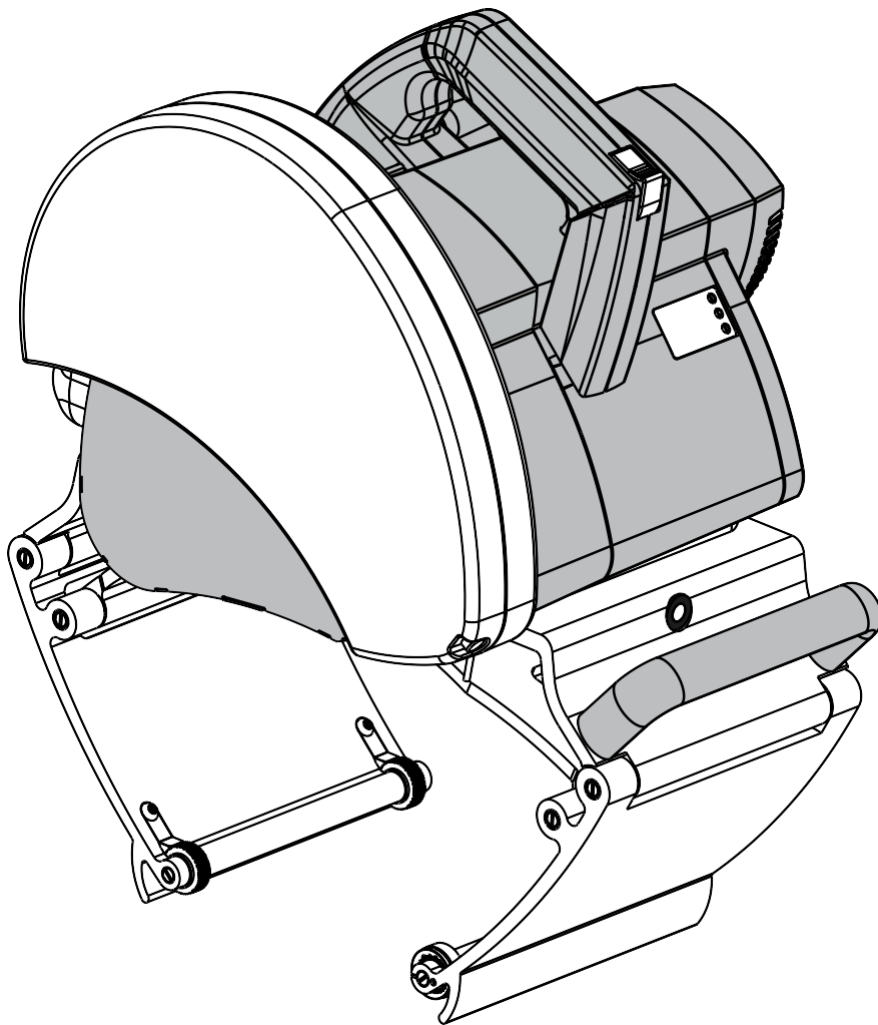

These are the translated instructions from the original instructions written in English.
All instructions are available on web-site: exacttools.com/manuals

exact Patent pending

Exact PipeCut 360 / 460 Pro Series 2.0

Data of Exact PipeCut saw blades

1. Exact TCT saw blades are for cutting steel, copper, aluminum and all kinds of plastics pipe materials. Exact TCT saw blades can be sharpened.
2. Exact CERMET saw blades are for cutting stainless steel, acid proof materials, steel, copper, aluminum and all kind of plastic pipe materials. Exact CERMET saw blades can be sharpened.
3. Exact CERMET ALU saw blades are for cutting all kind of aluminum and plastic pipe materials. Exact CERMET ALU saw blades can be sharpened.
4. Exact TCT P blades are for cutting all kinds of plastic pipe materials. Exact TCT P saw blades can be sharpened.
5. Exact INOX blades are for cutting the hardest stainless steel and acid proof steel. EXACT INOX saw blades can be sharpened.
6. Exact DIAMOND X discs are for cutting Cast or Ductile Iron only. Exact DIAMOND X discs cannot be sharpened.

360 Pro Series 2.0 / 460 Pro Series 2.0 speed control recommendations:

Stainless steel	I
Steel	II
Cast-iron	II
Plastics	II

Declaration of Conformity

We declare under our sole responsibility that the pipe cutting machines Exact PipeCut 360 / 460 Pro Series 2.0 Described under "Technical Data" are in conformity with the following standards or standardization documents:
IEC 62841-1:2014, IEC 62841-2-5:2014, EN 62841-1:2015, EN 62841-2-5:2014, EN 55014-1, EN 55014-2, EN 61000-3-2, EN 61000-3-3
according to the technical provisions of the directive 2006/42/EC

These are the original instructions written in English.

For more information, please contact Exact Tools at the following address:
The technical file is available at the address underneath:
The person authorized to compile the technical file:

Marko Törrönen, Chief Technology Officer (marko.torronen@exacttools.com)

Helsinki, 01.10.2024

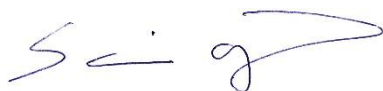

Sami Ojamo
CEO
Exact Tools Oy
Martinkyläntie 41
FI-01720 Vantaa, Finland

FIGURE A

- 1 Unlocking switch
- 2 Power switch
- 3 Power switch locking lever (in front of the switch)
- 4 Blade guard cover
- 5 Overload indicator light
- 6 Moving blade-guard
- 7 Adjusting screw
- 8 Laser pointer box
- 9 Adjusting wheel (360PS 2.0)
- 10 Handle
- 11 Blade guard screw
- 12 Lock pin
- 13 Rating plate
- 14 Motor unit
- 15 Blade RPM speed control
- 16 Adjustment arrow
- 17 Adjustment slot
- 18 Gripping device adjusting knob
- 19 Gripping device locking collar
- 20 Gripping device
- 21 Laser pointer batteries (inside the blade protection)
- 22 Battery seat cover (inside the blade protection)
- 23 Laser Pointer (inside the blade protection)
- 24 Handle to carry the saw
- 25 Laser switch
- 26 Adjusting plate
- 27 Depth adjustment roller
- 28 Adjusting wheel (460PS 2.0)

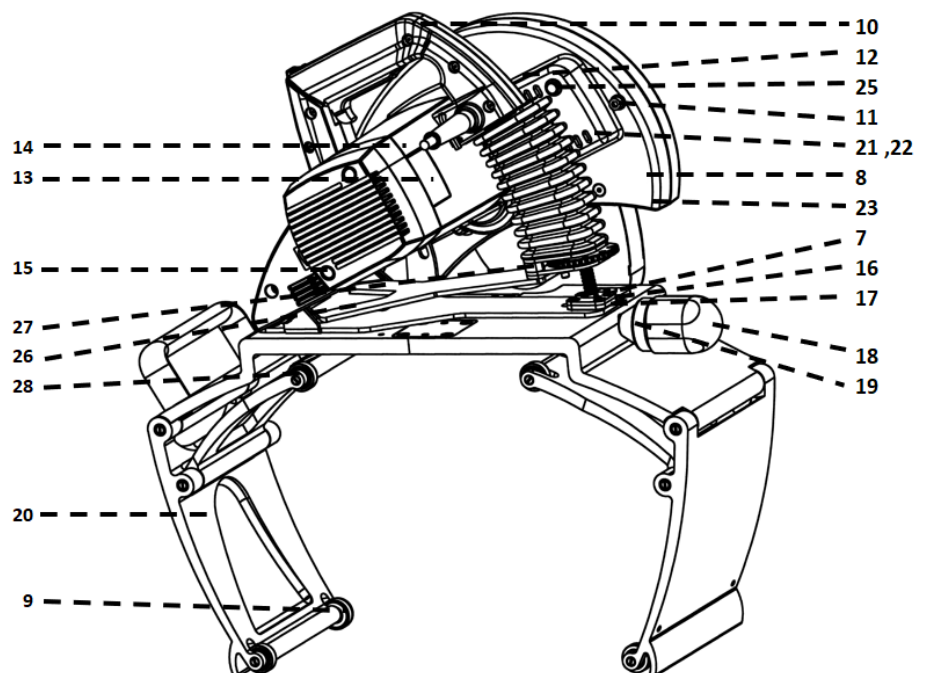
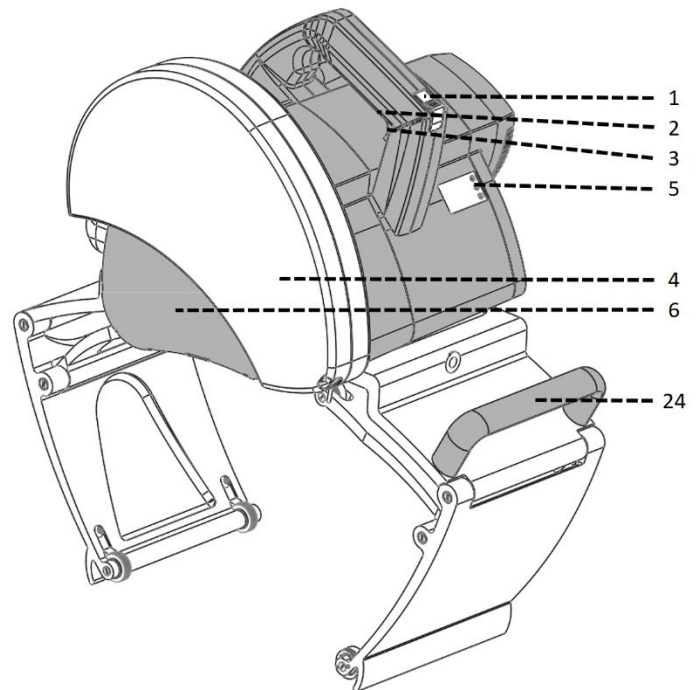

WITH THE CUT+BEVEL PACKAGE (SOLD SEPARATELY):

FIGURE A2

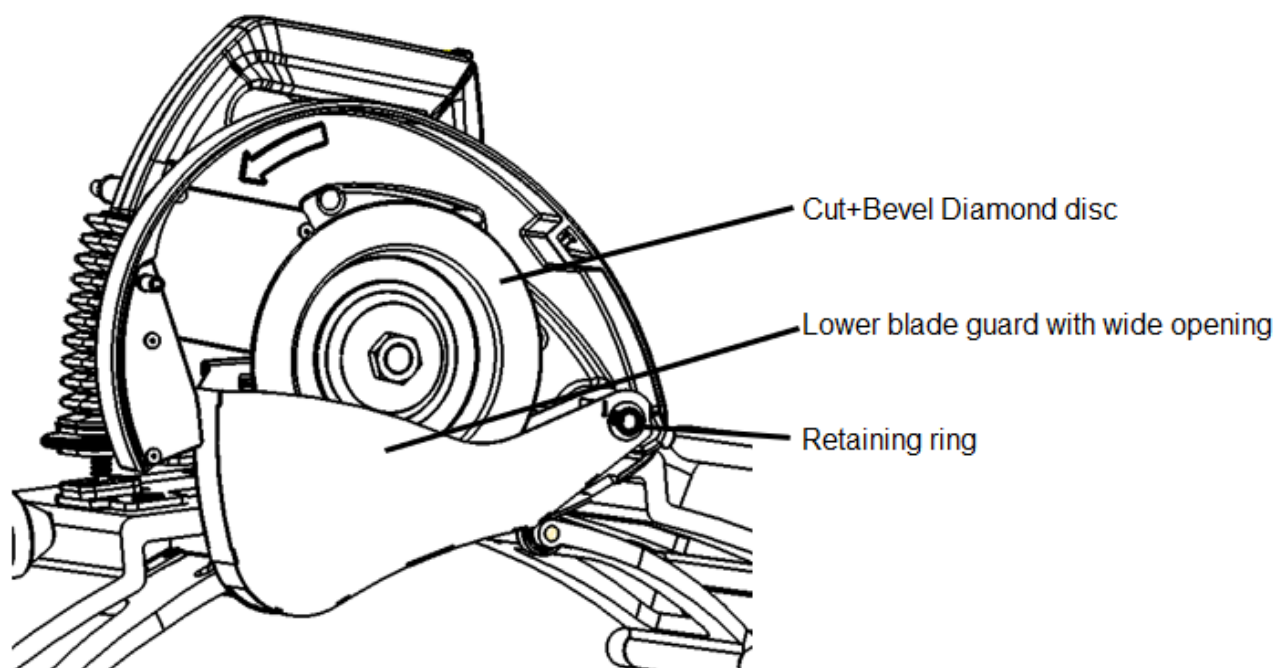

Information

Technical data	6
Package contents	7

Safety

Safety instructions	8
---------------------	---

Operation

Functional description	10
Product features	11
Before operating the tool	12
Connection to mains power supply	12
Setting the pipe on supports	12
Attaching the pipe saw to pipe	12
Piercing the pipe wall	12
Cutting around the pipe	13
Overload protection and RPM adjustment	14
Explanation if indicator lights	14
Error code display	15
Improving possible misalignment of the cut	15
Cutting result adjustment	16
Installing and changing the blade	17
Maintenance and servicing instructions	17
Environment / disposal	18
Guarantee / guarantee conditions	18
Tips for using Exact PipeCut saws	18
Extra equipment	19
Changing the lower blade guard	20
Blade suitability	21
Theoretical cutting depths	22

Exact PipeCut 360 / 460 Pro Series 2.0

Voltage	230 V / 50–60 Hz / 120 V 50–60Hz
Power	2500 W – 230 V / 15 A – 120 V
No-load speed	I (low) = 1900/min, II (high) = 2885 /min
Blade diameter	140 – 190 mm (5.6" – 7.6")
Mounting bore	62 mm (2.44")
Weight	PipeCut 360 Pro Series 2.0: 17,5 kg (40 lbs), PipeCut 460 Pro Series 2.0: 18,5 kg (42 lbs)
Range of PipeCut 360 Pro Series 2.0	75 mm–360 mm (3.0"–14")
Range of use PipeCut 460 Pro Series 2.0	100 mm–460 mm (4"–18")
Max. pipe wall, plastics and other soft materials	50 mm (2.0")
Max. Pipe wall 230V, steel, iron	20 mm / 0.78"
Max. Pipe wall 120V, steel, iron	12 mm / 0.5"
Protection class	□ / II
Spindle lock	Yes
Speed preselection	Yes
Constant electronic control	Yes
Overload Protection	Yes
Reduced starting current	Yes
Vibration, $A_{h,M}$ "cutting metal"	3,2 m/s ²
Vibration uncertainty, K	0,3 m/s ²
LpA (sound pressure)	101,0 dB(A)
KpA (sound pressure uncertainty)	3 dB(A)
LWA (acoustic power)	112,0 dB(A)
KWA (acoustic power uncertainty)	3 dB(A)
Recommended generator capacity	4,9kVA for 230V, 3kVA for 100 V-120V

The values given are valid for nominal voltages [U] of 230/240 V. For lower voltage and models for specific countries, these values can vary.

Exact PipeCut 360 / 460 Pro Series 2.0 pipe cutting systems

Package contents, please check that the package contains the following items:

1. Exact PipeCut System Shoulder Bag
2. Exact PipeCut 360 / 460 Pro Series 2.0 pipe saw
3. Pipe Cutting supports 1 + 2 pcs.
4. Operating instructions
5. Allen key 2 pcs (5 mm and 2 mm)
6. Cermet 165 saw blade installed to the pipe saw

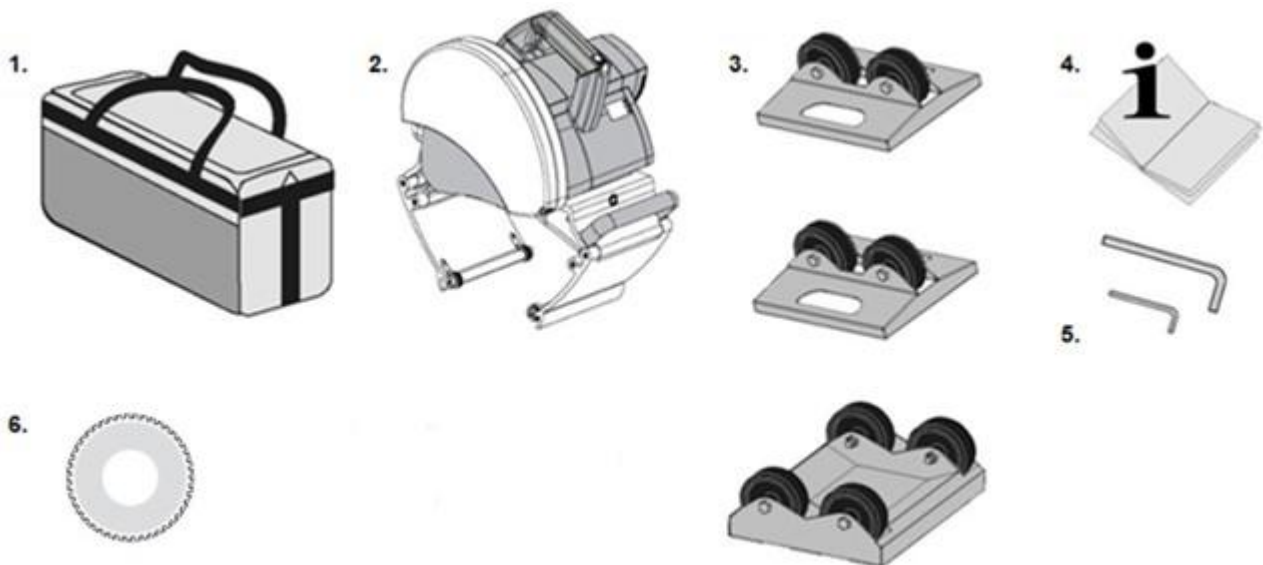



Definitions: Safety instructions

The definitions below describe the level of severity for each signal word. Please read the manual and pay attention to these symbols

 **DANGER:** Indicates an imminently hazardous situation which, if not avoided, will result in serious injury or in extreme cases a fatality

 **WARNING:** Indicates a potentially hazardous situation which, if not avoided, could result in serious injury or in extreme cases a fatality

 **CAUTION:** Indicates a potentially hazardous situation which, if not avoided, may result in minor or moderate injury.

 **NOTICE:** Indicates a practice not related to personal injury which, if not avoided, may result in property damage.

 **Denotes risk of electric shock.**

Symbols found on the machine.

 **Use ear protection.**

 **Use gloves.**

 **Read instructions before use.**

 **Laser radiation:** Do not look directly into beam.



Saw blade: Saw blade behind this cover, do not insert fingers or other body parts inside this cover.

Operating, safety and service instructions

Read these operating, safety and service instructions carefully before operating the pipe saw.

Store these instructions in a place where all pipe saw operators have access. In addition to these instructions official work, health and safety rules must be followed. Exact PipeCut is for professional use only.

Please notice the article number on the type plate of your machine. The trade names of the individual machines may vary.

Only for power tools without reduced starting current: Starting cycles generate brief voltage drops. Interference with other equipment/machines may occur in case of unfavorable mains system conditions. Malfunctions are not to be expected for system impedances below 0.36 ohm.

Noise/vibration Information

The vibration emission level given in this information sheet has been measured in accordance with a standardized test given in EN62481-2-5:2014

Use ear protection!

Vibration level values (sum of vectors of three directions) are defined in accordance with standard EN62841-2-5:2014:

Vibration rate $a_{h,M}$ "cutting metal" = 3.2 m/s²,
Uncertainty K = 0,3 m/s².

The vibration emission level given in this information sheet has been measured in accordance with a standardized test given in EN62841-2-5:2014 and may be used to compare one tool with another. It may be used for a preliminary assessment of exposure.

 **WARNING:** The declared vibration emission level represents the level during main applications of the tool.

However, if the tool is used for different applications, with different accessories or poorly maintained, the vibration emission may differ. This may significantly increase the exposure level over the total working period.

An estimation of the level of exposure to vibration should also take into account the times when the tool is switched off or when it is running but not actually doing the job. This may significantly reduce the exposure level over the total working period.

Identify additional safety measures to protect the operator from the effects of vibration such as: maintain the tool and the accessories, keep the hands warm, organize work patterns.

 **WARNING:**

If Exact PipeCut 360 / 460 Pro Series 2.0 tool is used with generator or extension cords, their minimum requirements are as follows:

Generator: minimum power of 3500 watts, if other electrical equipment is not used at the same time.

Extension cords 230 V: The maximum length - 25 meters. Cable cross section - not less than 2,5mm².

Extension cords 120 V: The maximum length – 82 Feet Extra Heavy Duty

General power tool safety warnings



WARNING: Read all safety warnings, illustrations and specifications provided with this power tool. Failure to follow all instructions listed below may result in electric shock, fire and/or serious injury

Save all warnings and instructions for future reference.

The term “power tool” in the warnings refers to your mains operated (corded) power tool or battery-operated (cordless) power tool.

1 Work area safety

- a) **Keep work area clean and well lit.** Cluttered or dark areas invite accidents.
- b) **Do not operate power tools in explosive atmospheres, such as in the presence of flammable liquids, gases or dust.** Power tools create sparks which may ignite the dust or fumes.
- c) **Keep children and bystanders away while operating a power tool.** Distractions can cause you to lose control.

2 Electrical safety

- a) **Power tool plugs must match the outlet. Never modify the plug in any way. Do not use any adapter plugs with earthed (grounded) power tools.** Unmodified plugs and matching outlets will reduce risk of electric shock.
- b) **Avoid body contact with earthed or grounded surfaces, such as pipes, radiators, ranges and refrigerators.** There is an increased risk of electric shock if your body is earthed or grounded.
- c) **Do not expose power tools to rain or wet conditions.** Water entering a power tool will increase the risk of electric shock
- d) **Do not abuse the cord. Never use the cord for carrying, pulling or unplugging the power tool. Keep cord away from heat, oil, sharp edges or moving parts.** Damaged or entangled cords increase the risk of electric shock
- e) **Damaged cable should be changed in the authorized service center.**
- f) **When operating a power tool outdoors, use an extension cord suitable for outdoor use.** Use of a cord suitable for outdoor use reduces the risk of electric shock.
- g) **If operating a power tool in a damp location is unavoidable, use a residual current device (RCD) protected supply.** Use of an RCD reduces the risk of electric shock
- h) **Hold electric tools by isolated handles, because during the operation it can connect to flush conductor or its own cord.** If tool connects to voltage-carrying cables, voltage can pass to metal parts and it increases the risk of electric shock.

3 Personal safety

- a) **Stay alert, watch what you are doing and use common sense when operating a power tool. Do not use a power tool while you are tired or under the influence of drugs, alcohol or medication.** A moment of inattention while operating power tools may result in serious personal injury.
- b) **Use personal protective equipment. Always wear eye protection.** Protective equipment such as dust mask, non-skid safety shoes, hard hat, or hearing protection used for appropriate conditions will reduce personal injuries.
- c) **Prevent unintentional starting. Ensure the switch is in the off-position before connecting to power source and/or battery pack, picking up or carrying the tool.** Carrying power tools with your finger on the switch or energizing power tools that have the switch on invites accidents.
- d) **Never operate the tool, if blade covers are not in place.**
- e) **Remove any adjusting key or wrench before turning the power tool on.** A wrench or a key left attached to a rotating part of the power tool may result in personal injury.
- f) **Do not overreach. Keep proper footing and balance at all times.** This enables better control of the power tool in unexpected situations.
- g) **Dress properly. Do not wear loose clothing or jewelry. Keep your hair and clothing away from moving parts.** Loose clothes, jewelry or long hair can be caught in moving parts.
- h) **Do not put your hands inside the pipe during the operation.** Take care, that no one will put anything inside the pipe during the operation.
- i) **Do not let familiarity gained from frequent use of tools allow you to become complacent and ignore tool safety principles.** A careless action can cause severe injury within a fraction of a second.
- j) **Support the pipe to cut securely.** Pipe supports are more reliable for holding the pipe than bare hands.
- k) **If devices are provided for the connection of dust extraction and collection facilities, ensure these are connected and properly used.** Use of dust collection can reduce dust-related hazards.

4 Cutting procedures

- a)  **DANGER: Keep hands away from cutting area and the blade. Keep your second hand on auxiliary handle, or motor housing.** If both hands are holding the saw, they cannot be cut by the blade.
- b) **Do not reach underneath the workpiece.** The guard cannot protect you from the blade below the workpiece.
- c) **Adjust the cutting depth to the thickness of the workpiece.** Less than a full tooth of the blade teeth should be visible below the workpiece.
- d) **Never hold the workpiece in your hands or across your leg while cutting. Secure the workpiece to a stable platform.** It is important to support the work properly to minimize body exposure, blade binding, or loss of control.
- e) **Hold the power tool by insulated gripping surfaces, when performing an operation where the cutting tool may contact hidden wiring or its own cord.** Contact with a "live" wire will also make exposed metal parts of the power tool "live" and could give the operator an electric shock.
- f) **When ripping, always use a rip fence or straight edge guide.** This improves the accuracy of cut and reduces the chance of blade binding.
- g) **Always use blades with correct size and shape (diamond versus round) of arbour holes.** Blades that do not match the mounting hardware of the saw will run off-centre, causing loss of control.
- h) **Never use damaged or incorrect blade washers or bolt.** The blade washers and bolt were specially designed for your saw, for optimum performance and safety of operation.

5 Lower guard function

- a) **Check the lower guard for proper closing before each use. Do not operate the saw if the lower guard does not move freely and close instantly. Never clamp or tie the lower guard into the open position.** If the saw is accidentally dropped, the lower guard may be bent. Raise the lower guard with the retracting handle and make sure it moves freely and does not touch the blade or any other part, in all angles and depths of cut.
- b) **Check the operation of the lower guard spring. If the guard and the spring are not operating properly, they must be serviced before use.** Lower guard may operate sluggishly due to damaged parts, gummy deposits, or a build-up of debris.
- c) **The lower guard may be retracted manually only for special cuts such as "plunge cuts" and "compound cuts". Raise the lower guard by the retracting handle and as soon as the blade enters the material, the lower guard must be released.** For all other sawing, the lower guard should operate automatically.

d) **Always observe that the lower guard is covering the blade before placing the saw down on bench or floor.** An unprotected, coasting blade will cause the saw to walk backwards, cutting whatever is in its path. Be aware of the time it takes for the blade to stop after switch is released.

6 Power tool use and care

- a) **Do not force the power tool. Use the correct power tool for your application.** The correct power tool will do the job better and safer at the rate for which it was designed.
- b) **Do not use the power tool if the switch does not turn it on and off.** Any power tool that cannot be controlled with the switch is dangerous and must be repaired.
- c) **Disconnect the plug from the power source and/or remove the battery pack, if detachable, from the power tool before making any adjustments, changing accessories, or storing power tools.** Such preventive safety measures reduce the risk of starting the power tool accidentally.
- d) **Store idle power tools out of the reach of children and do not allow persons unfamiliar with the power tool or these instructions to operate the power tool.** Power tools are dangerous in the hands of untrained users.
- e) **Maintain power tools and accessories. Check for misalignment or binding of moving parts, breakage of parts and any other condition that may affect the power tool's operation. If damaged, have the power tool repaired before use.** Many accidents are caused by poorly maintained power tools.
- f) **Keep cutting tools sharp and clean.** Properly maintained cutting tools with sharp cutting edges are less likely to bind and are easier to control.
- g) **Use the power tool, accessories and tool bits etc. in accordance with these instructions, taking into account the working conditions and the work to be performed.** Use of the power tool for operations different from those intended could result in a hazardous situation.
- h) **Keep handles and grasping surfaces dry, clean and free from oil and grease.** Slippery handles and grasping surfaces do not allow for safe handling and control of the tool in unexpected situations.
- i) **Do not use damaged or faulty blades or blade flanges.** Blade flanges and nuts are custom made for this tool to ensure optimum operating performance and safety.

7 Service

Have your power tool serviced by a qualified repair center using only identical replacement parts. This will ensure that the safety of the power tool is maintained.

Further safety instructions

The pipe saw must never be used in the following cases, if:

- There is water or another liquid, explosive gases or poisonous chemicals inside the pipe to be cut.
- The power switch is faulty.
- The power cable is faulty.
- The blade is bent.
- The blade is dull or in poor condition.
- The plastic components are cracked or have parts missing.
- The gripper unit is not properly tightened around the pipe or if it is warped.
- The blade guard cover or moving blade guard has been damaged or removed from the machine.
- The locking mechanisms do not work properly (UNLOCK - SWITCH).
- The pipe saw has become wet.

When you use the saw, the following factors shall be considered:

- Fasten the pipes to be cut properly so that the blade is not clamped between the ends of the pipes.
- Make sure that the pipe to be cut is empty.
- Make sure that the pipe is installed correctly.
- Make sure that the diameter and thickness of the blade is suitable for the saw and that the blade is suitable for rotational speed selected
- Never use axial friction force to stop the blade, let it stop freely.
- Check the parts of the blade protection.
- Never apply excessive force when using the pipecut.
- Never use the pipecut to lift the pipe when fixed on the pipe.
- Avoid excessive load on the electric motor.
- Always follow safety and operation manual and applicable regulations.

Description of the work

Read all manuals and warnings carefully. If warnings and instructions are not complied with, the risk of electric shock, fire and/or severe damage to life may occur.

Intended Use

PipeCut 360 / 460 Pro Series 2.0

PipeCut 360 / 460 Pro Series 2.0 pipe saw to be used as a pipe fitter's tool at the job site.

PipeCut 360 / 460 Pro Series 2.0 pipe saw is not intended for use in industrial production.

PipeCut 360 / 460 Pro Series 2.0 can only be used to cut round pipes, with a diameter of:

360 Pro Series 2.0: 75 mm–360 mm (3"–14")
460 Pro Series 2.0: 100 mm–460 mm (4"–18")

Maximum wall thickness:

Steel 20 mm (0.8"), 230V

12 mm (0,5"), 120V

Plastic 50mm (2")

PipeCut 360 / 460 Pro Series 2.0 pipe saw can be used to cut all normal pipe materials, such as steel, stainless steel, cast/ductile iron, copper, aluminum and plastic. Use a specific blade for each pipe material.

See the cutting depth table on page 22.

With additional accessories PipeCut 360 / 460 can also be used for simultaneous cutting and beveling of cast or ductile iron pipes. See page 20 for more information.

Use pipe holders to support the pipe being cut.

Before operating the tool

- Ensure that the motor unit is in the upright position.
- Check that the disc is correctly fitted, in good condition and suitable for the material to be cut.
- Ensure the pipe saw guide wheels rotate.
- Ensure the support wheels rotate.
- Check the operation of the lower blade guard.
- Ensure the pipe is empty.
- If making Cut+Bevel to cast iron, ensure that the Cut+Bevel Diamond disc is installed to the saw.
- Make sure that wide lower blade guard is installed with the Cut+Bevel Diamond disc. Regular blade cover does not have big enough opening for the Cut+Bevel Diamond disc.

⚠ WARNING: Regular lower blade cover **must** be installed if saw is used with regular saw blade with cutting teeth.

Connection to the mains power supply

Ensure that the mains voltage is the same as indicated on the rating plate (Fig A / 13). Connect the pipe saw to the power outlet only after having checked the above points first.

Setting the pipe on supports

Use the system supports when cutting pipes. This will ensure safe working and optimum results. Work on flat surface. Place the pipe on two supports so that the cutting point is between the supports. Place two more supports under both ends of the pipe. Check that all support wheels contact the pipe (adjust if required e.g. with pieces of lumber) (Fig B1). When cutting short and light weight pipes, place the supports so that the cutting point is outside supports (Fig B2). Support the pipe with your left leg, if required. Proper arrangements will prevent the blade from jamming as the pipe is cut through.

Attaching the pipe saw to the pipe

Open the pipe saw's gripper unit enough to go over the pipe by rotating the adjustment handle located at the rear of the saw (Fig C / 1). If you are using laser pointer for position, Cut+Bevel Diamond disc 165 will cut the pipe 15mm to the right of the laser line. Fasten the pipe saw to the pipe by turning the gripper adjustment handle until the gripper grips firmly the pipe to be cut (Fig C / 2).

Lock the mechanism by turning the gripper locking collar (Fig C / 3). Hold the pipe in place and ensure that pipe saw moves freely in the direction the pipe is fed. For sake of safety ensure the pipe saw power cord is on the left side of the pipe saw.

Now you are ready for cutting.

FIGURE B1

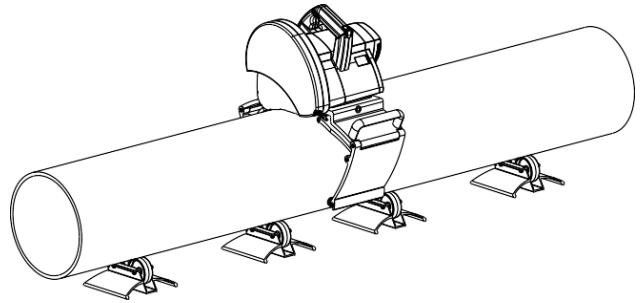

FIGURE B2

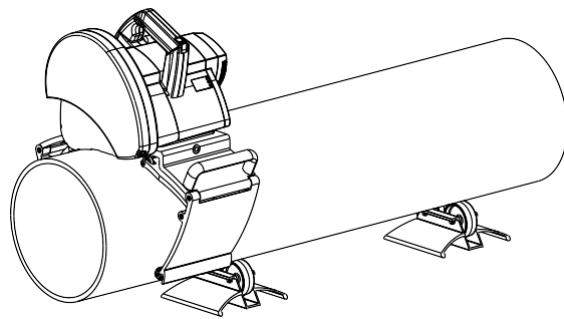
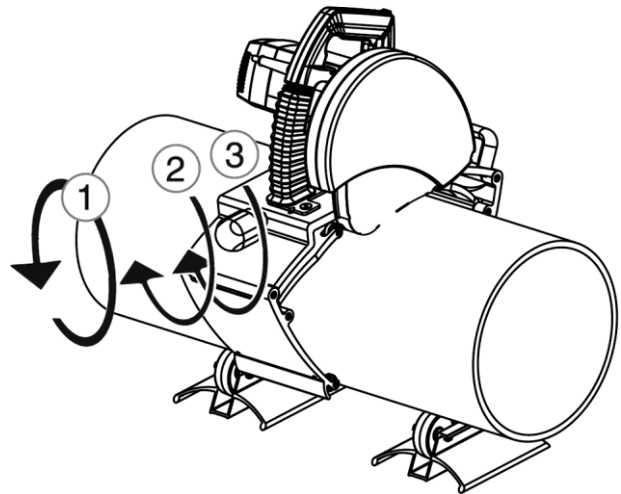

FIGURE C



Piercing the pipe wall

Grip the handle firmly with your right hand and place your left foot on top of the pipe left from the pipe saw. Turn the saw until it leans slightly forward (Figure F). To start the motor, push the power-switch locking lever forwards (Fig D/1) and push the power switch all the way down (Fig D/2).

Before starting to cut, wait until the blade reaches full speed. Pierce the pipe wall by pressing pipe saw operating handle downwards slowly and evenly. At this stage prevent the pipe from rotating with your left foot.

Look at the UNLOCK SWITCH during the piercing operation. When the yellow mark disappears on UNLOCK SWITCH (Fig E / 1-2), the blade has pierced the pipe wall and the saw is locked in the cutting position (Fig F/1).

You can safely start cutting around the pipe.

You can use the upper position to cut multi-layered pipes made of multiple materials. Adjust contact length as needed with depth adjustment dial (Fig A).

Cutting around the pipe

Start cutting by feeding the pipe saw forward while keeping the pipe from rotating with your left foot (Fig F / 2).

After feeding movement lift your foot from the pipe and pull the pipe saw towards you. The pipe will rotate backwards with the saw (Fig G). Start a new feeding movement, and feed continuously forward roughly 1/6 of the pipe's circumference (Fig H). Repeat until the pipe is cut off.

Use feeding speed suitable for the material and the thickness of the wall. Indicator lights (Fig J) will guide you to reach the correct feed rate. While green is lit, you can continue cutting with current feed rate or even push more. When yellow starts to blink, slow down.

When the pipe is cut off, push the UNLOCK SWITCH forward until the yellow mark is visible and the locking is released (Fig I / 1). Now raise the motor unit to the up position (Fig I / 2) and release the power switch (Fig I / 3). Ensure that the moving lower blade-guard is lowered and covers the blade completely.

After the blade has stopped, release the gripper locking collar (Fig I / 4) and release the pipe saw from the pipe by loosening the gripper adjustment handle (Fig I / 5).

If there is any problems, abnormal sounds or vibrations during piercing or cutting and you need to interrupt cutting before the pipe is cut through, release the motor unit locking by pushing the UNLOCK SWITCH forward until the UNLOCK SWITCH is released and lift the motor unit up. Once the problem is cleared, start cutting again.

Never start the motor, when the motor unit is in cutting position or teeth of the blade are in contact with the pipe.

FIGURE D

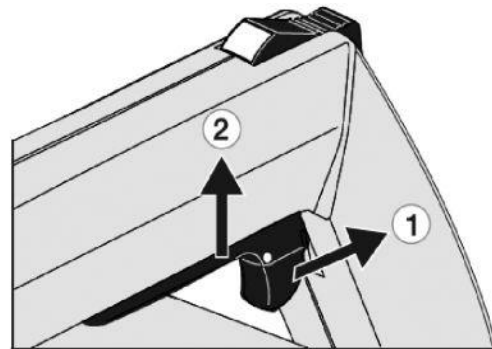

FIGURE E

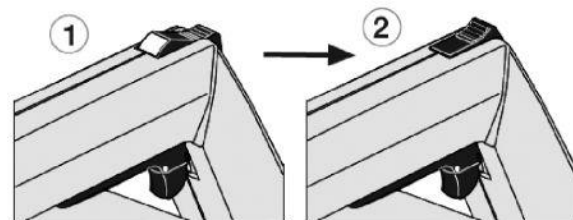

FIGURE F

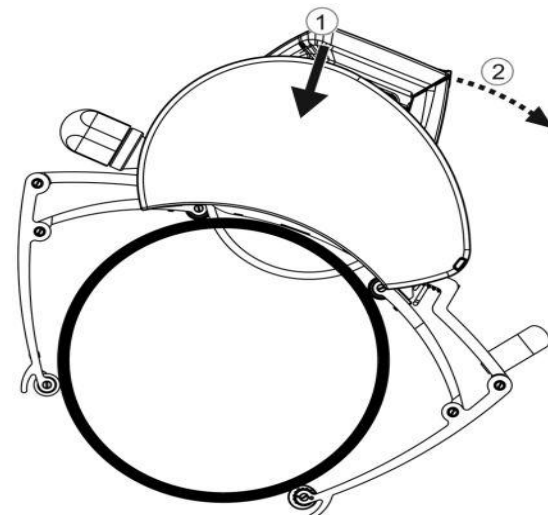
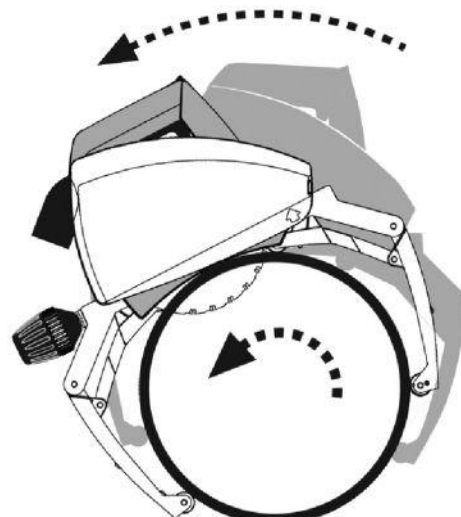

FIGURE G



Overload protector and blade RPM speed control

The saw has a two-speed blade RPM speed control (Fig A / 15). When cutting stainless or acid-proof steel use the lower RPM setting I. When cutting other materials use the faster RPM setting II.

The saw has overload protection circuit and displays motor load with three indicator lights (Fig A / 5).

Explanation of indicator lights (FIGURE J)

Normal operation	Green: ON Yellow: OFF Red: OFF
Normal power output	
WARNING Motor temperature rising	Green: OFF Yellow: Blinking Red: OFF
Normal power output	
WARNING Motor current high	Green: OFF Yellow: Blinking Red: OFF
Normal power output	
STOP! Motor temperature too high	Green: OFF Yellow: OFF Red: Blinking
Power output very low, enough for cooling with free running	
WARNING Temperature sensor faulty	Green: OFF Yellow: ON Red: OFF
Power output low to finish the work	

GREEN If green light is on, the motor temperature and power output are normal.

➔ **You can continue cutting and try to increase feed rate**

YELLOW If yellow light begins to flash, the motor is overloaded, or the temperature is rising.

➔ **You should slow down the cutting speed** (It is possible, that you are using a worn-out blade)

RED If the red light begins to flash, motor power is automatically reduced to the minimum to protect the motor. Cutting is not possible.

➔ **Lift the motor unit up so that the blade is not in contact with the pipe. Keep the motor running and let it run freely (UNDER NO LOAD) until the green light is on.**

ATTENTION!

If the yellow light turns on before starting cutting, it indicates that the motor temperature sensor has been damaged and overload protection does not work.

You can finish the sawing, but the saw needs to be taken to service.

If the problem is not solved, the motor will get damaged.

FIGURE H

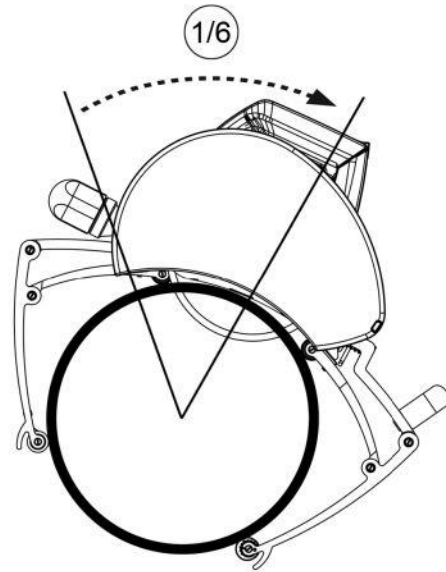

FIGURE I

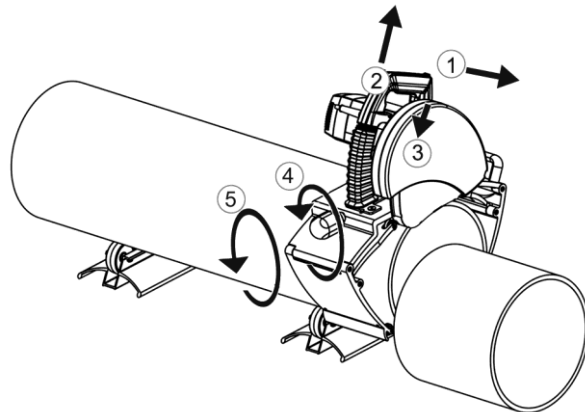

FIGURE J

	GO AHEAD
	WARNING
	RUN THE MOTOR UNTIL GREEN LIGHT IS ON

Error code display

If the electronic control unit senses an error situation, it will give an error code indicating the fault. This error code is given by blinking the green light.

Code will consist of blinks followed by a short pause. Longer pauses are kept between the codes.

To be able to read the codes, the main switch needs to be kept on after the motor has stopped.

The buzzing sound you may hear is not an indication of a possible short-circuit.

List of error codes can be found below.

No. of blinks	Error description
1	Mains frequency too high
2	Mains frequency too low
3	Mains voltage malformed
4	Mains voltage too high
5	Internal reference error
6	Current too high or too low during soft-start
7	No speed signal during soft-start
8	Speed sensor open during soft-start
9	Speed sensor signal invalid during soft-start
10	Motor overload during operation
11	Motor overload during cooling free run
12	Motor overload during temperature sensor error
13	No speed signal during operation
14	Speed sensor open during operation
15	Speed sensor signal invalid during operation

Cutting result adjustment for models Exact PipeCut 360 / 460 Pro Series 2.0:

Improving possible misalignment of the cut

The cut is affected by many factors, e.g. the size of the pipe, the material, the wall thickness, the quality of the pipe's surface, the roundness, welded seams, blade condition, feed rate, operator's experience. For this reason, the saw may move to left or right causing unperfect cut (see Fig K).

FIGURE K

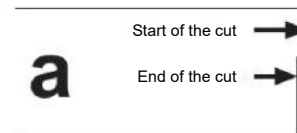

Saw has moved from right to left

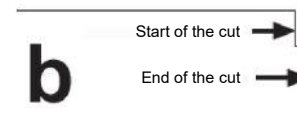

Saw has moved from left to right

Adjustment wheel

There are eight wheels on the gripping units of models 360 Pro Series 2.0 and 460 Pro Series 2.0 and one of them is the adjustment wheel. On 360 Pro Series 2.0 this wheel is one of the lower wheels (Fig A/9) and on 460 Pro Series 2.0 the adjustment wheel is one of the upper wheels.

Please note that adjustment by this wheel might be valid only one pipe size and the wheel may need to be adjusted again for different pipe sizes.

Adjust the wheel by releasing the locking screw (Fig L / 1) and turning the central part of the wheel **CLOCKWISE** or **ANTICLOCKWISE** to obtain the desired position (Fig L / 2) and lock the wheel again (Fig L/3).

If the saw is moving from right to left (FIG K/a), turn the central part of the adjustment wheel so that "d" is smaller (FIGURE L/a).

If the saw is moving from left to right (FIG K/b), turn the central part of the adjustment wheel so that "d" is bigger (Fig L/b).

It is recommended to lubricate the adjusting wheel periodically.

Motor unit adjustment

In these models the angle of the entire motor unit can be adjusted left or right. This adjusts the blade angle related to the pipe. The laser beam can be used to aid in correct adjustment.

Adjustment steps

1. Mark the reference line precisely on the pipe at an angle of 90 degrees in the longitudinal direction.
2. Place the saw on the pipe so that the red line of the laser is next to the reference line at an angle of 90 degrees. Tighten the griper to the normal tension level. Check if the laser line and reference line are parallel. In Fig M/a the laser beam is not parallel with the reference line.
3. Release the two locking screws of the adjustment plate (Fig M/b 1 and 2).
4. Adjust the motor unit to the left or right as needed to get the laser beam and the reference line parallel. In Fig M/c the laser beam is parallel with the reference line.
5. Tighten the locking screws of the adjustment plate tightly to keep the adjustment in place.

CAUTION The adjustment indicator located in the back of the adjustment plate does not give the exact measurement to adjust. The indicator shows only the direction of adjustment and magnitude.

CAUTION If the motor unit is adjusted with the laser, the gripping device must be attached to the pipe with normal tension. This ensures that the saw fastening corresponds to the normal condition of operation.

If you are not satisfied with the cutting result of your saw and you need to adjust it again then always start by adjusting the eccentric adjustment wheel.

FIGURE L

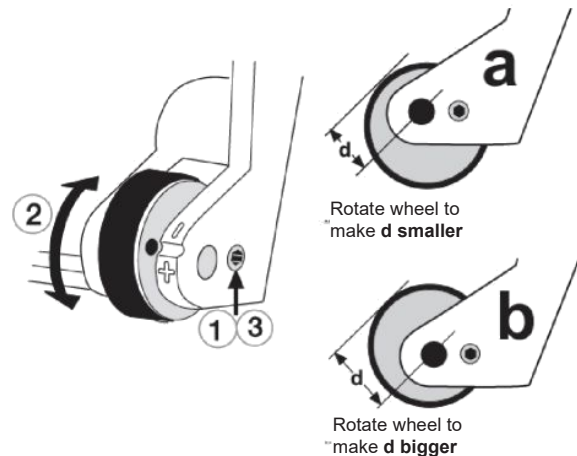

FIGURE M /a

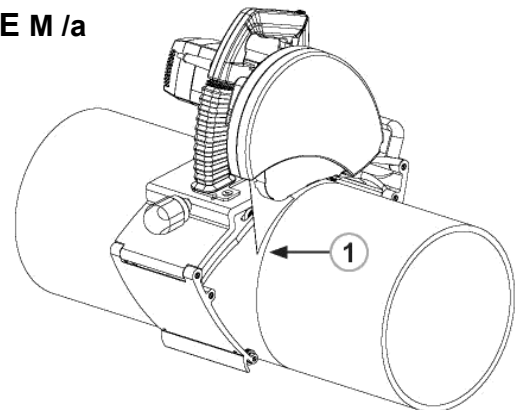

FIGURE M /b

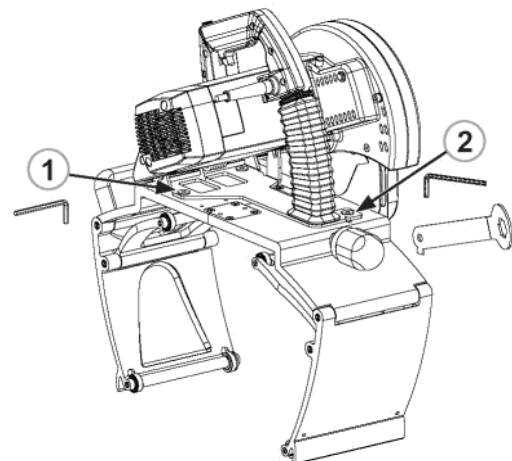
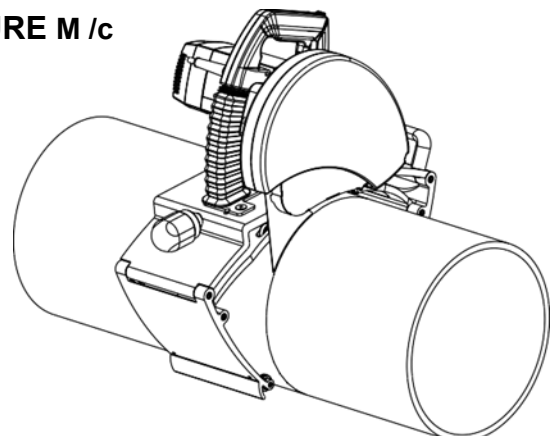

FIGURE M /c



Installing and changing the saw blade

⚠ WARNING: To reduce the risk of injury, disconnect the saw from the power source before installing and removing accessories, before adjusting or when making repairs. An accidental start-up can cause injury.

Remove the blade guard cover (Fig N / 1) by opening the blade guard screw (Fig N / 2). Press the spindle-lock button (Fig A / 12) and at the same time rotate the blade by hand until the spindle-lock button goes further down locking the blade rotation.

Use the 5mm hex key to open the blade bolt. Remove the blade bolt, washer and pulling flange washer (Fig N / 3). Take out the outer blade flange (Fig N / 4) and the blade (Fig N / 5).

Before installing a new blade, check that both blade flanges are clean. Place a new or sharpened blade on the inner blade flange (Fig N / 6), so that the marked side of the blade is facing outwards and the arrows on the blade are facing in the same direction as the rotation direction markings on the inside of the blade cover. Ensure that the new blade sits tight on the bottom of the inner blade flange. Put the outer blade flange, the pulling flange washer, washer and blade bolt in place. Press the spindle lock button and tighten the blade bolt. Put the blade guard cover back in place and tighten the blade cover bolt.

When changing to Cut+Bevel Diamond disc, before attaching the diamond disc, change also the lower blade cover. Lower blade guard with wide opening is needed to clear Cut+Bevel Diamond disc. Refer to instructions on page 20.

⚠ WARNING: Regular lower blade cover **must** be installed if saw is used with regular saw blade with cutting teeth.

FIGURE N

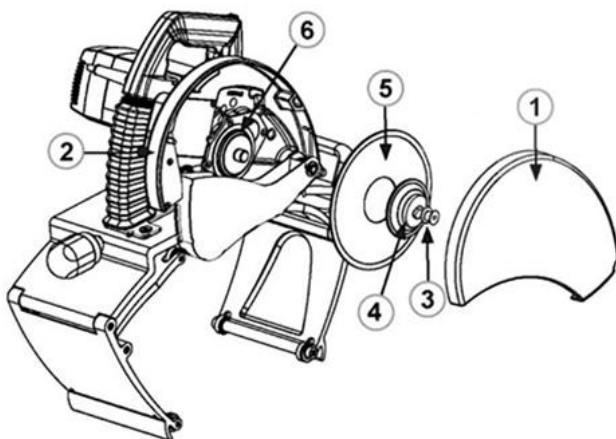

Maintenance and servicing instructions

Disconnect the saw from the power source before servicing or cleaning the pipe saw. All maintenance operations carried out on the pipe saw's electrical components must be carried out by an approved service center or engineer.

Blade

Check the condition of the blade. Replace a bent, blunt, or otherwise damaged blade with a new one. Using a blunt blade can overload the pipe saw's electric motor and gearbox. When you notice that the blade is blunt, do not continue cutting with it, as the blade may become so badly damaged that it will not be worth sharpening. A blade in sufficiently good condition can be sharpened a few times by a professional sharpening company. Diamond X Discs cannot be sharpened.

Gripper unit

Clean the gripper unit regularly with compressed air. Pay attention to trapezoidal screw threads (Fig O / 4).

Lubricate the gripper's wheels, axles (Fig O / 1 and 3) and joints (Fig O / 2).

Blade guard

When you have cut plastic pipes and then intend to start cutting metal pipes always clean the inside of the blade guards. Hot metal particles originating from metal cutting will heat up plastic debris, which may release toxic smoke.

Make it a rule to clean the blade guard regularly and pay special attention to keep the lower blade guard moving as freely. Lubricate the axis of the moving blade guard regularly.

As an extra equipment you can buy outer blade guard with connection for vacuum cleaner. For extra equipment see page 19.

Motor

Keep motor air vents clean to allow free airflow.

FIGURE O

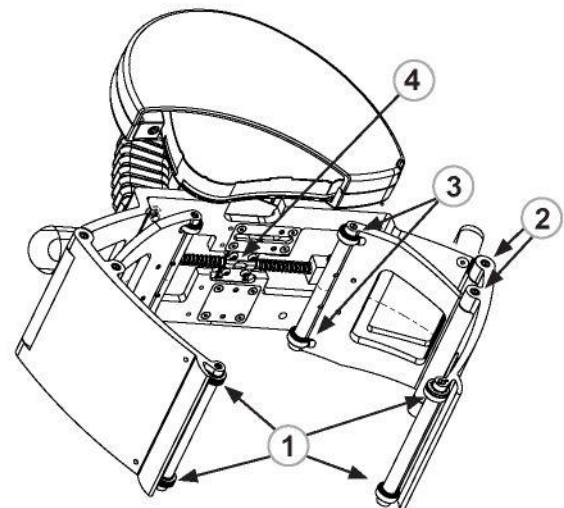

Plastic parts

Clean the plastic parts with a soft rag. Use only mild detergents. Do not use solvents or other strong detergents as they may damage the plastic parts and painted surfaces

Power cable

Check the condition of the power cable regularly. A faulty power cable should always be replaced at an approved service center. Correct use and regular servicing and cleaning will ensure the reliable operation of the pipe saw.

Environment / disposal

Separate collection. This product must not be disposed with normal household waste. When your Exact PipeCut machine is worn out, do not dispose it with normal household waste. This product must be recycled separately.

Separate recycling of used products and packaging support recycling and recovery of materials. Reusing recycled materials helps preventing the pollution of the environment.

According to local regulations it is possible to deliver household appliances to municipal waste depositories or to the dealer when purchasing a new product.

Guarantee

Warranty terms valid from 01.01.2025.

If the Exact PipeCut saw becomes unusable due to material or manufacturing defects within the Warranty Term, at our discretion we will repair the Exact PipeCut Saw or supply an entirely new or factory reconditioned Exact PipeCut Saw at no charge.

For Pro Series models the Exact Tools Warranty Term is for 24 months from date of purchase.

The Warranty is only valid if:

- 1.) Copy of a dated purchase receipt is returned to the Authorized Warranty Repair Center or has been uploaded to our website at the time of warranty registration.
- 2.) The Exact PipeCut Saw has not been misused.
- 3.) No attempt has been made by non-approved persons to repair the saw.
- 4.) The Exact PipeCut Saw has been used in accordance with the operating, safety, and servicing instructions provide in these instructions.
- 5.) The Exact PipeCut Saw has been delivered to an Authorized Warranty Repair Center within the warranty period.

NOTICE! The Exact PipeCut Saw is to be shipped to the Authorized Warranty Repair Center freight prepaid. If the Exact PipeCut Saw is repaired under Warranty, the return shipment will be made freight prepaid.

CAUTION!

The following items or services are excluded for Warranty claims:

- Saw blades
- Carbon brushes
- Blade flanges
- Blade attachment bolt
- Normal wear
- Failures caused by misuse or accident
- Water, fire or physical damage
- Broken wires
- Adjustment of eccentric adjustment wheel
- If a wrong type of generator has been used as a power source.

Exact Pipe Cut operation tips

Diamond blades can be used for cutting cast or ductile iron pipes. This pipe material is not recommended to cut using to a blade of any other type

Clean the inside of the blade guards after cutting plastic pipes.

Check the condition of the blade regularly.

The cutting process is divided into two stages: first you need to cut through the pipe wall and then cut around the pipe.

Avoid overloading the saw while working without interruption. The saw can overheat, and metal parts can become very hot. In this case, red indicator light will come on and motor power is reduced to only allow for cooling with free running.

Maintain a uniform feed rate. This increases the lifespan of the blade. For example, a steel pipe with an outer diameter of 170 mm (6") and wall thickness of 5 mm (1/5"), the cutting time-is 15-20 seconds. Accordingly cast iron pipe with an outer diameter of 4" (110 mm) and wall thickness of 1/6" (4 mm), the cutting time is 20 – 25 seconds.

When not cutting, keep the motor unit in the up position. Never place the tool on the pipe with motor unit in locked down to cutting position.

Factors influencing blade lifespan:

- Pipe material
- Blade suitability for the pipe material
- Correct motor speed setting
- Pipe wall thickness
- Feed rate
- Smoothness of the pipe
- General user knowledge
- Cleanliness of the pipe
- Corrosion on pipe
- Weld seam on the pipe
- Blade speed
- Too tight blade

Factors influencing straightness of cutting:

- Blade condition
- Pipe wall thickness
- Feed rate
- Smoothness of feed
- General user knowledge
- Cleanliness of the pipe
- Pipe circumference
- Too loose or tight gripping device

Extra equipment for 360 – 460 PS 2.0:

Blade cover with vacuum cleaner connection for plastic cutting

FIGURE P

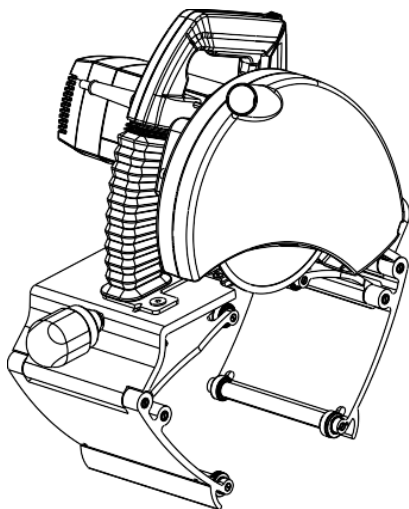

By using this blade guard and vacuum cleaner, most of the plastic chips can be removed from the blade guard and prevent the chips from spreading on the cutting work area.

It is not recommended to use vacuum cleaner connection when cutting metal. Hot metal debris from cutting may cause damage to vacuum unit and / or plastic connection pipes.

Extra equipment for 360 – 460 PS 2.0: Exact Cut+Bevel package for cast iron / ductile pipes

Cut+Bevel features

When using Diamond Cut + Bevel disc, the bevel depth and width is adjusted with depth adjustment dial (page 3, Figure A). Turning the dial clockwise will make deeper and wider bevel and turning it counterclockwise will make smaller and thinner bevel.

Please note that the adjustment dial only affects the position when the motor unit is locked down. It does not move the motor unit if it is not locked down.

When using the machine on a new pipe size, adjust the cutting depth higher than needed prior to cutting. It is easier to make the cut deeper by adjusting the depth adjustment dial during cutting. Correct depth setting is confirmed with visual evaluation of the cutting result.

The depth setting does not change if the depth adjustment dial is not moved. Therefore Cut + Bevel cuts can be made on same size pipes without any additional adjustment.

Beveling forces will push the saw to the right. To compensate these and achieve a straight cut, motor unit needs to be turned counterclockwise. The size of this adjustment depends on the pipe material, wall thickness, and bevel size. Therefore, it is not possible to provide a single optimal adjustment position.

To make the adjustment:

- Loosen the two screws on the body plate
- Turn bodyplate counterclockwise
- Tighten the screws

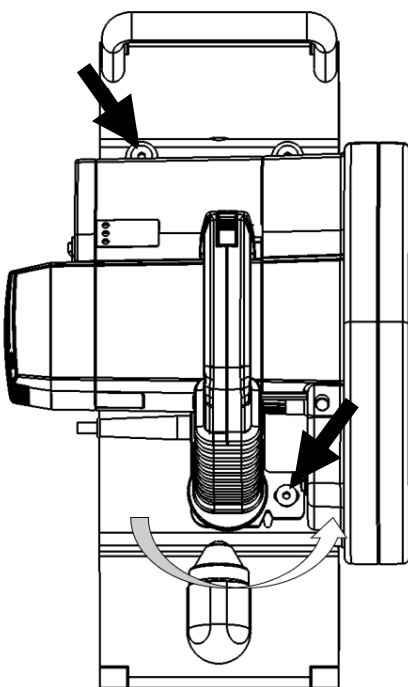

Changing the lower blade guard

When using the Cut+Bevel Diamond disc, be sure to use also the lower blade guard with wider opening on the bottom. Regular lower blade guard does not work with Cut+Bevel Diamond disc.

Lower blade guard is changed as follows (see also figure A2 on page 4):

- Remove blade and blade flanges from the saw if fitted.

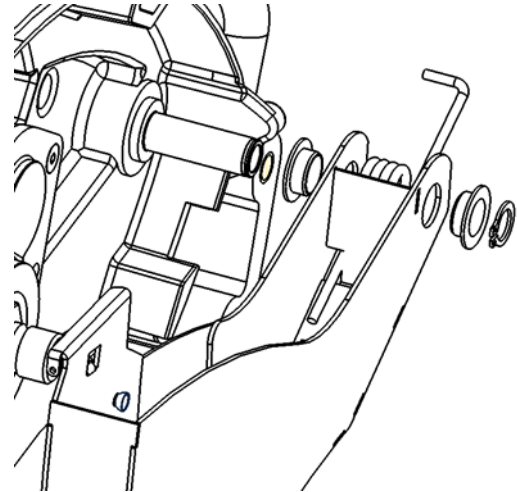

- Remove the retaining ring from the axle.
- Pull the lower blade guard, washer, spring and bushings of the axle. Note the locations of bushings and spring.
- Insert bushings to the lower blade guard to be installed
- Insert the lower blade guard with bushings, washer and spring on the axle. Be sure to locate the spring correctly.
- Test the correct function of the lower blade guard, it will return to low position when released and that it can move without any restriction.

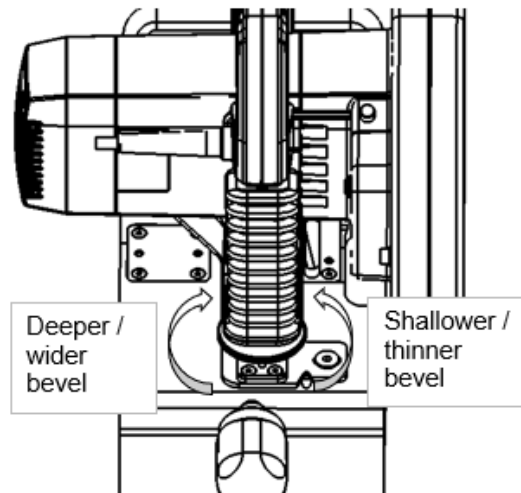

Blade suitability

Exact TCT: Suitable for cutting steel and all kinds of plastic pipe material

Exact Cermet: Suitable for cutting stainless steel and acid proof materials, steel, copper, aluminum and all kind of plastic pipe materials.

Exact INOX: Suitable especially for the hardest stainless steel and acid proof steel.

Exact ALU: Suitable for cutting aluminum and all kinds of plastic.

Exact Diamond: Suitable only for cutting cast and ductile iron pipe materials, also for concrete lined cast iron pipes.

Exact TCT 140
Exact TCT Z140
Exact Cermet 140
Exact Cermet 140 THIN
Exact INOX 140
Exact INOX 140 THIN
Exact ALU 140
Exact Diamond X 140
Exact TCT 165
Exact Cermet 165
Exact ALU165
Exact Diamond X 165
Exact Cermet 180
Exact ALU 180
Exact Diamond X 180
Exact Plastic 190

Exact Cut+Bevel Diamond disc 140
Exact Cut+Bevel Diamond disc 165



Theoretical maximum cutting depths

360 PS 2.0 Max. Pipe wall / mm					460 PS 2.0 Max. Pipe wall / mm				
with different diameter blades					with different diameter blades				
OD [mm]	Blade 140	Blade 165	Blade 180	Blade 190	OD [mm]	Blade 140	Blade 165	Blade 180	Blade 190
50	–	–	–	–	50	–	–	–	–
75	21	34	41	46	75	–	–	–	–
100	16	28	36	41	100	25	37	45	50
110	15	28	35	40	110	22	34	42	47
115	15	27	35	40	115	21	33	41	46
140	14	27	35	40	140	18	31	38	43
165	15	28	35	40	165	17	30	37	42
215	18	30	38	43	215	18	30	37	42
270	21	34	41	46	270	19	32	39	44
320	24	37	44	49	320	21	34	41	46
355	26	39	46	51	355	23	35	43	48
410	–	–	–	–	410	24	37	44	49
460	–	–	–	–	460	25	37	45	50

Maximum recommended pipe wall thicknesses in different pipe materials, which can be cut by Exact PipeCut 360 / 460 Pro Series 2.0 machines
European model 230V / 2500W

Steel pipes	Max.pipe wall thickness 20 mm / 0.78"
Stainless steel pipes	Max.pipe wall thickness 20 mm / 0.78"
Cast or ductile iron pipes	Max.pipe wall thickness 20 mm / 0.78"
Any types of plastic, aluminum, copper	Pipe wall thickness according to tables above

USA model 120V / 15A

Steel pipes	Max.pipe wall thickness 12 mm / 0.5"
Stainless steel pipes	Max.pipe wall thickness 12 mm / 0.5"
Cast or ductile Iron pipes	Max.pipe wall thickness 12 mm / 0.5"
Any types of plastic, aluminum, copper	Pipe wall thickness according to tables above

ATTENTION! Do not cut pipes with thicker than the above-mentioned wall thicknesses.

ATTENTION! Check the status and condition of the blade before cutting

Due to the continuous product development, the present manual may be modified. No changes will be reported separately.

For more information check www.exacttools.com