

## PipeCut 170E/220E System

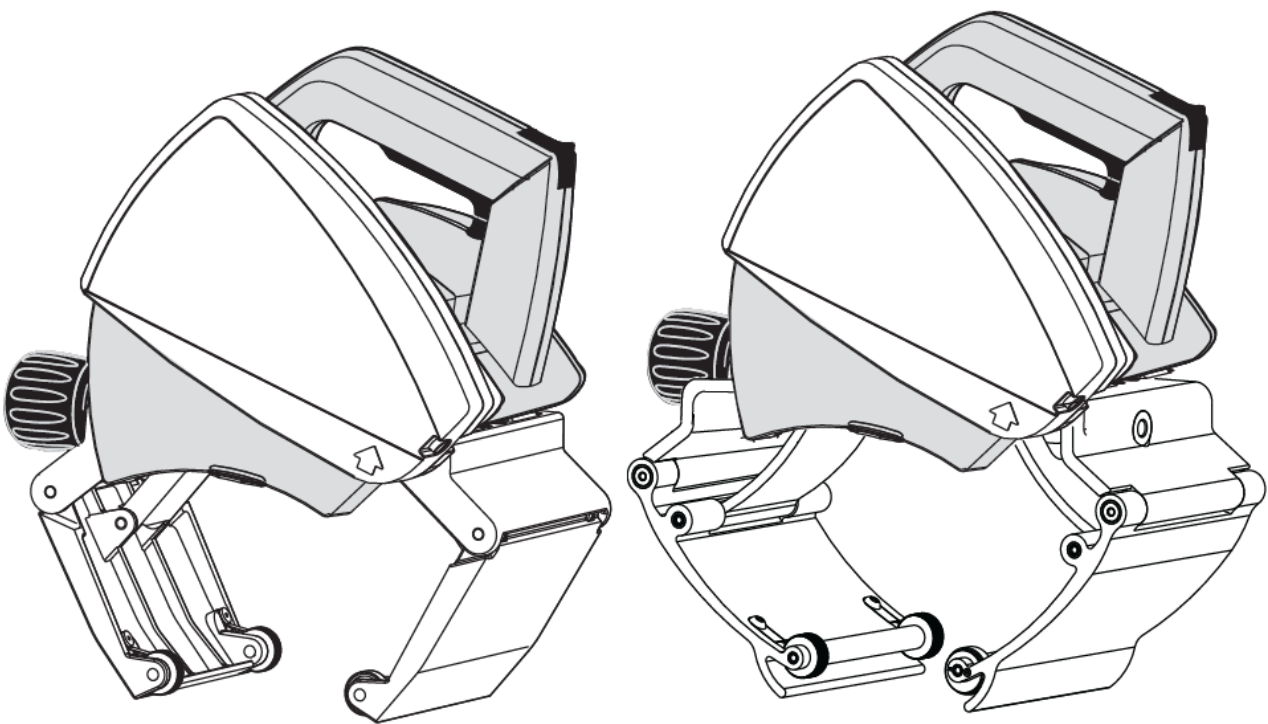

These are the original instructions.

All instructions are available on website: [exacttools.com/manuals](http://exacttools.com/manuals)

## Exact PipeCut 170E/220E

### Blade information for Exact PipeCut saws

**TCT** (tungsten carbide tip) saw blades are for cutting steel, copper, aluminium and all kind of plastics. TCT blades can be sharpened.

**Cermet** (ceramic alloy tip) saw blades are for cutting stainless steel, acid proof materials, steel, copper, aluminium and all kind of plastics. Cermet blades can be sharpened.

**Diamond** blades are for cutting cast iron only. Diamond blades can not be sharpened.

170E/220E speed control recommendations:

Stainless steel 4

Steel 6

Cast-iron 6

## Declaration of Conformity

We declare under our sole responsibility that the pipe cutting machines Exact PipeCut 170E/220E Described under "Technical Data" are in conformity with the following standards or standardization documents:  
EN 62841-1:2015 + A11:2022, EN 62841-2-5:2014,  
EN 55014-1:2017 + A11:2020, EN 55014-2:1997 + A2:2008, EN 61000-3-2:2014, EN 61000-3-3:2013,  
according to the technical provisions of the directives 2006/42/EC and 2014/30/EU

For more information, please contact Exact Tools at the address below.

The technical file is available at the address underneath.

The person authorized to compile the technical file:

Marko Törrönen, Chief Technology Officer, Exact Tools Oy (marko.torronen@exacttools.com)

Helsinki, 02.01.2024

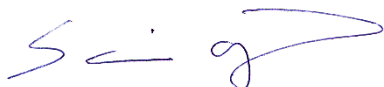

Sami Ojamo  
Managing Director  
Martinkyläntie 41  
FI-01720 Vantaa  
Finland

FIGURE A

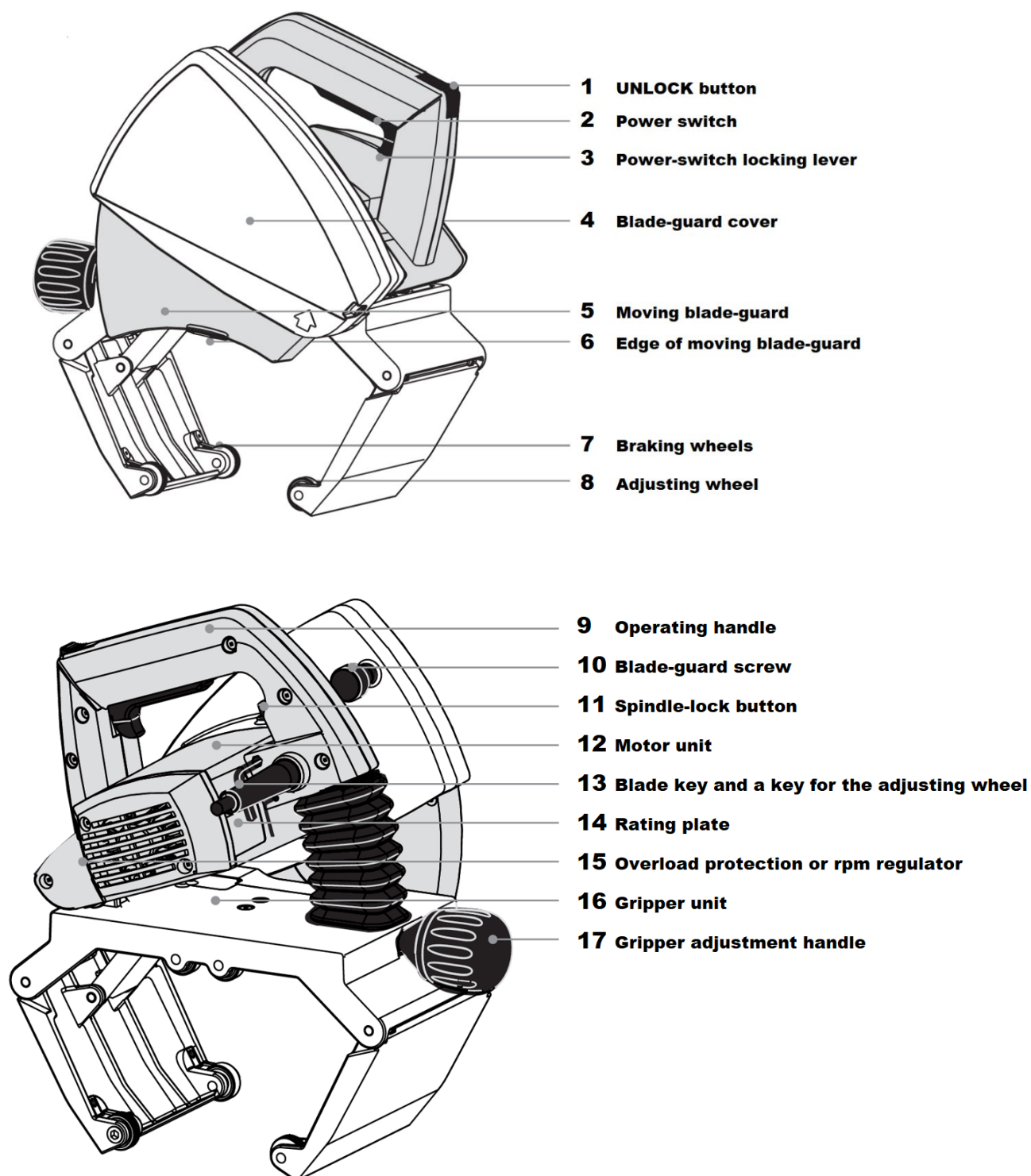

**Contents****Information**

Technical data	5
Package contents	5

**Safety**

Safety instructions	6
---------------------	---

**Operation**

Intended use	9
Before operating the tool	10
Connection to mains power supply	10
Setting the pipe on supports	10
Attaching the pipe saw to the pipe	10
Piercing the pipe wall	11
Sawing around the pipe	11
Overload protection	12
Improving possible misalignment of the cut	12
Installing and changing the blade	13
Maintenance and servicing instructions	14
Environment / disposal	14
Guarantee / guarantee conditions	14
Tips for using Exact PipeCut saws	15
Contact information	16

## Exact PipeCut 170E/220E pipe saw

Voltage	230 V / 50–60 Hz or 120 V 50–60Hz
Power	1200 W - 230 V / 9.2 A - 120 V
No-load speed	1600-35000 r/min
Blade diameter	140 mm (5.51")
Mounting bore	62 mm (2.44")
Weight	5,7 kg (12 lbs) 170E, 5,9 kg (13 lbs) 220E
Range of use Ø 170E/220E	15 mm - 170 mm (0,6" - 6") 170E 15 mm - 220 mm (0.6" - 8.6") 220E
Max. pipe wall, steel	8 mm (0.3")
Max. pipe wall, plastics	15 mm (0.55")
Protection class	□ / II
Spindle lock	Yes
Speed preselection	Yes
Constant electronic control	Yes
Overload Protection	Yes
Reduced starting current	Yes
Vibration, $A_n$	< 2,5 m/s <sup>2</sup>
Vibration uncertainty, K	1,5 m/s <sup>2</sup>
LpA (sound pressure)	92 dB(A)
KpA (sound pressure uncertainty)	2,5 dB(A)
LWA (acoustic power)	103 dB(A)
KWA (acoustic power uncertainty)	2,5 dB(A)
Recommended generator capacity	2500 watts

The values given are valid for nominal voltages [U] of 230 V. For lower voltage and models for specific countries, these values can vary.

## Exact PipeCut 170E/220E pipe cutting system

Package contents, please check that the package contains the following items:

- Exact PipeCut System Shoulder Bag
- Exact PipeCut 170E or 220E pipe saw
- Pipe Cutting supports 4 pcs
- Operating instructions
- 5 mm and 2.5 mm allen keys attached to saw
- TCT blade 140 x 62 fitted on the machine

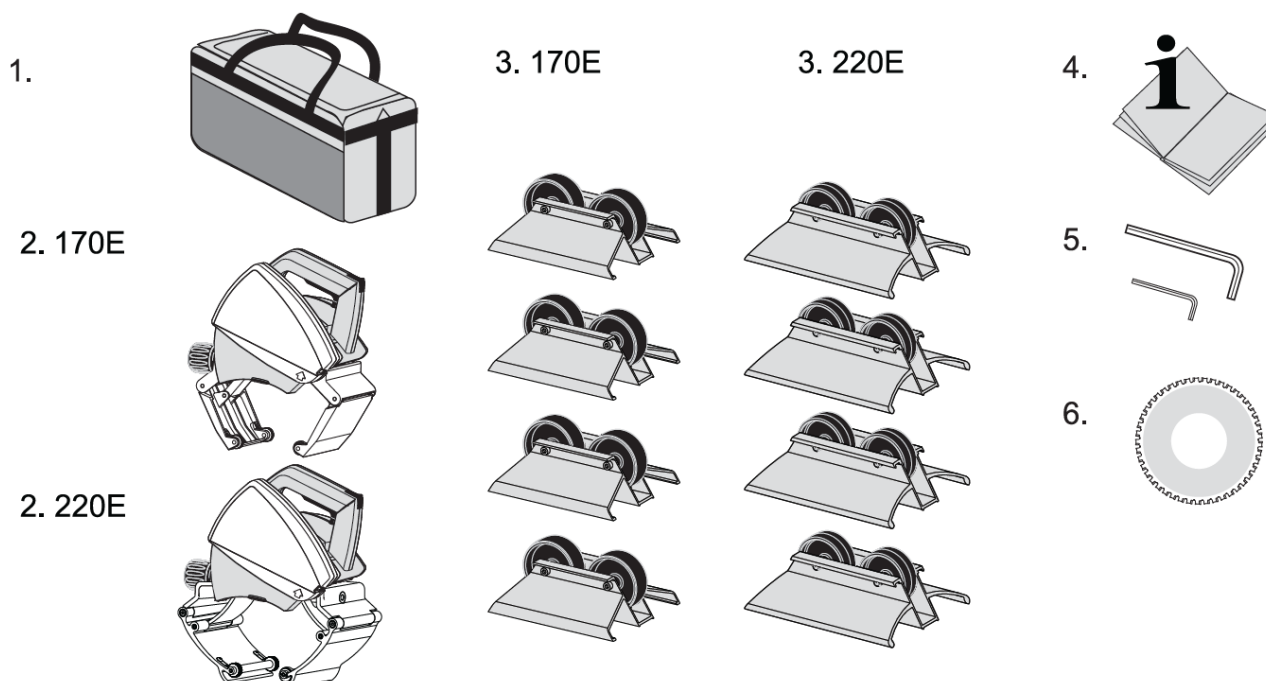



## Definitions: Safety instructions

The definitions below describe the level of severity for each signal word. Please read the manual and pay attention to these symbols

 **DANGER:** Indicates an imminently hazardous situation which, if not avoided, will result in serious injury or in extreme cases a fatality

 **WARNING:** Indicates a potentially hazardous situation which, if not avoided, could result in serious injury or in extreme cases a fatality

 **CAUTION:** Indicates a potentially hazardous situation which, if not avoided, may result in minor or moderate injury.

 **NOTICE:** Indicates a practice not related to personal injury which, if not avoided, may result in property damage.

 **Denotes risk of electric shock.**

### Symbols found on the machine.



Use ear protection.



Use gloves.



Read instructions before use.



**Saw blade:** Saw blade behind this cover, do not insert fingers or other body parts inside this cover.

### Operating, safety and service instructions

Read these operating, safety and service instructions carefully before operating the pipe saw.

Store these instructions in a place where all pipe saw operators have access. In addition to these instructions official work, health and safety rules must be followed. Exact PipeCut is for professional use only.

Please notice the article number on the type plate of your machine. The trade names of the individual machines may vary.

Only for power tools without reduced starting current: Starting cycles generate brief voltage drops. Interference with other equipment/machines may occur in case of unfavorable mains system conditions. Malfunctions are not to be expected for system impedances below 0.36 ohm.

#### Noise/vibration Information

The vibration emission level given in this information sheet has been measured in accordance with a standardized test given in EN62481-2-5:2014

#### Use ear protection!

**Vibration level values** (sum of vectors of three directions) are defined in accordance with standard EN62841-2-5:2014:

Vibration rate  $a_h = < 2,5 \text{ m/s}^2$ ,  
Uncertainty  $K = 1,5 \text{ m/s}^2$ .

The vibration emission level given in this information sheet has been measured in accordance with a standardized test given in EN62841-2-5:2014 and may be used to compare one tool with another. It may be used for a preliminary assessment of exposure.

 **WARNING:** The declared vibration emission level represents the level during main applications of the tool.

However, if the tool is used for different applications, with different accessories or poorly maintained, the vibration emission may differ. This may significantly increase the exposure level over the total working period.

An estimation of the level of exposure to vibration should also take into account the times when the tool is switched off or when it is running but not actually doing the job. This may significantly reduce the exposure level over the total working period.

Identify additional safety measures to protect the operator from the effects of vibration such as: maintain the tool and the accessories, keep the hands warm, organize work patterns.

 **WARNING:**

If Pipecut Exact PipeCut 170E/220E tool is used with generator or extension cords, their minimum requirements are as follows:

Generator: minimum power of 2500 watts, if other electrical equipment is not used at the same time.

Extension cords 230 V: The maximum length - 25 meters. Cable cross section - not less than 1,5mm<sup>2</sup>.

Extension cords 120 V: The maximum length – 82 Feet Heavy Duty

## General power tool safety warnings



**WARNING:** Read all safety warnings, illustrations and specifications provided with this power tool. Failure to follow all instructions listed below may result in electric shock, fire and/or serious injury

**Save all warnings and instructions for future reference.**

The term "power tool" in the warnings refers to your mains operated (corded) power tool or battery-operated (cordless) power tool.

### 1 Work area safety

- a) **Keep work area clean and well lit.** Cluttered or dark areas invite accidents.
- b) **Do not operate power tools in explosive atmospheres, such as in the presence of flammable liquids, gases or dust.** Power tools create sparks which may ignite the dust or fumes.
- c) **Keep children and bystanders away while operating a power tool.** Distractions can cause you to lose control.

### 2 Electrical safety

- a) **Power tool plugs must match the outlet. Never modify the plug in any way. Do not use any adapter plugs with earthed (grounded) power tools.** Unmodified plugs and matching outlets will reduce risk of electric shock.
- b) **Avoid body contact with earthed or grounded surfaces, such as pipes, radiators, ranges and refrigerators.** There is an increased risk of electric shock if your body is earthed or grounded.
- c) **Do not expose power tools to rain or wet conditions.** Water entering a power tool will increase the risk of electric shock
- d) **Do not abuse the cord. Never use the cord for carrying, pulling or unplugging the power tool. Keep cord away from heat, oil, sharp edges or moving parts.** Damaged or entangled cords increase the risk of electric shock
- e) **When operating a power tool outdoors, use an extension cord suitable for outdoor use.** Use of a cord suitable for outdoor use reduces the risk of electric shock.
- f) **If operating a power tool in a damp location is unavoidable, use a residual current device (RCD) protected supply.** Use of an RCD reduces the risk of electric shock

### 3 Personal safety

- a) **Stay alert, watch what you are doing and use common sense when operating a power tool. Do not use a power tool while you are tired or under the influence of drugs, alcohol or medication.** A moment of inattention while operating power tools may result in serious personal injury.

b) **Use personal protective equipment. Always wear eye protection.** Protective equipment such as dust mask, non-skid safety shoes, hard hat, or hearing protection used for appropriate conditions will reduce personal injuries.

c) **Prevent unintentional starting. Ensure the switch is in the off-position before connecting to power source and/or battery pack, picking up or carrying the tool.** Carrying power tools with your finger on the switch or energizing power tools that have the switch on invites accidents.

d) **Remove any adjusting key or wrench before turning the power tool on.** A wrench or a key left attached to a rotating part of the power tool may result in personal injury.

e) **Do not overreach. Keep proper footing and balance at all times.** This enables better control of the power tool in unexpected situations.

f) **Dress properly. Do not wear loose clothing or jewelry. Keep your hair and clothing away from moving parts.** Loose clothes, jewelry or long hair can be caught in moving parts.

g) **If devices are provided for the connection of dust extraction and collection facilities, ensure these are connected and properly used.** Use of dust collection can reduce dust-related hazards.

h) **Do not let familiarity gained from frequent use of tools allow you to become complacent and ignore tool safety principles.** A careless action can cause severe injury within a fraction of a second.

### 4 Power tool use and care

a) **Do not force the power tool. Use the correct power tool for your application.** The correct power tool will do the job better and safer at the rate for which it was designed.

b) **Do not use the power tool if the switch does not turn it on and off.** Any power tool that cannot be controlled with the switch is dangerous and must be repaired.

c) **Disconnect the plug from the power source and/or remove the battery pack, if detachable, from the power tool before making any adjustments, changing accessories, or storing power tools.** Such preventive safety measures reduce the risk of starting the power tool accidentally.

d) **Store idle power tools out of the reach of children and do not allow persons unfamiliar with the power tool or these instructions to operate the power tool.** Power tools are dangerous in the hands of untrained users.

e) **Maintain power tools and accessories. Check for misalignment or binding of moving parts, breakage of parts and any other condition that may affect the power tool's operation. If damaged, have the power tool repaired before use.** Many accidents are caused by poorly maintained power tools.

f) **Keep cutting tools sharp and clean.** Properly maintained cutting tools with sharp cutting edges are less likely to bind and are easier to control.

g) **Use the power tool, accessories and tool bits etc. in accordance with these instructions, taking into account the working conditions and the work to be performed.** Use of the power tool for operations different from those intended could result in a hazardous situation.

h) **Keep handles and grasping surfaces dry, clean and free from oil and grease.** Slippery handles and grasping surfaces do not allow for safe handling and control of the tool in unexpected situations.

## 5 Service

**Have your power tool serviced by a qualified repair center using only identical replacement parts.** This will ensure that the safety of the power tool is maintained.

## Cutting procedures

- a)  **DANGER: Keep hands away from cutting area and the blade. Keep your second hand on auxiliary handle, or motor housing.** If both hands are holding the saw, they cannot be cut by the blade.
- b) **Do not reach underneath the workpiece.** The guard cannot protect you from the blade below the workpiece.
- c) **Adjust the cutting depth to the thickness of the workpiece.** Less than a full tooth of the blade teeth should be visible below the workpiece.
- d) **Never hold the workpiece in your hands or across your leg while cutting. Secure the workpiece to a stable platform.** It is important to support the work properly to minimize body exposure, blade binding, or loss of control.
- e) **Hold the power tool by insulated gripping surfaces, when performing an operation where the cutting tool may contact hidden wiring or its own cord.** Contact with a "live" wire will also make exposed metal parts of the power tool "live" and could give the operator an electric shock.
- f) **When ripping, always use a rip fence or straight edge guide.** This improves the accuracy of cut and reduces the chance of blade binding.
- g) **Always use blades with correct size and shape (diamond versus round) of arbour holes.** Blades that do not match the mounting hardware of the saw will run off-centre, causing loss of control.
- h) **Never use damaged or incorrect blade washers or bolt.** The blade washers and bolt were specially designed for your saw, for optimum performance and safety of operation.

## Further safety instructions

### Kickback causes and related warnings

- kickback is a sudden reaction to a pinched, jammed or misaligned saw blade, causing an uncontrolled saw to lift up and out of the workpiece toward the operator;
- when the blade is pinched or jammed tightly by the kerf closing down, the blade stalls and the motor reaction drives the unit rapidly back toward the operator;
- if the blade becomes twisted or misaligned in the cut, the teeth at the back edge of the blade can dig into the top surface of the wood causing the blade to climb out of the kerf and jump back toward the operator.

Kickback is the result of saw misuse and/or incorrect operating procedures or conditions and can be avoided by taking proper precautions as given below.

- a) **Maintain a firm grip with both hands on the saw and position your arms to resist kickback forces. Position your body to either side of the blade, but not in line with the blade.** Kickback could cause the saw to jump backwards, but kickback forces can be controlled by the operator, if proper precautions are taken.
- b) **When blade is binding, or when interrupting a cut for any reason, release the trigger and hold the saw motionless in the material until the blade comes to a complete stop. Never attempt to remove the saw from the work or pull the saw backward while the blade is in motion or kickback may occur.** Investigate and take corrective actions to eliminate the cause of blade binding.
- c) **When restarting a saw in the workpiece, centre the saw blade in the kerf so that the saw teeth are not engaged into the material.** If a saw blade binds, it may walk up or kickback from the workpiece as the saw is restarted.
- d) **Support large panels to minimize the risk of blade pinching and kickback.** Large panels tend to sag under their own weight. Supports must be placed under the panel on both sides, near the line of cut and near the edge of the panel.
- e) **Do not use dull or damaged blades.** Unsharpened or improperly set blades produce narrow kerf causing excessive friction, blade binding and kickback.
- f) **Blade depth and bevel adjusting locking levers must be tight and secure before making the cut.** If blade adjustment shifts while cutting, it may cause binding and kickback.
- g) **Use extra caution when sawing into existing walls or other blind areas.** The protruding blade may cut objects that can cause kickback.

### Lower guard function

a) **Check the lower guard for proper closing before each use. Do not operate the saw if the lower guard does not move freely and close instantly. Never clamp or tie the lower guard into the open position.** If the saw is accidentally

dropped, the lower guard may be bent. Raise the lower guard with the retracting handle and make sure it moves freely and does not touch the blade or any other part, in all angles and depths of cut.

b) **Check the operation of the lower guard spring. If the guard and the spring are not operating properly, they must be serviced before use.** Lower guard may operate sluggishly due to damaged parts, gummy deposits, or a build-up of debris.

c) **The lower guard may be retracted manually only for special cuts such as "plunge cuts" and "compound cuts". Raise the lower guard by the retracting handle and as soon as the blade enters the material, the lower guard must be released.** For all other sawing, the lower guard should operate automatically.

d) **Always observe that the lower guard is covering the blade before placing the saw down on bench or floor.** An unprotected, coasting blade will cause the saw to walk backwards, cutting whatever is in its path. Be aware of the time it takes for the blade to stop after switch is released.

### The pipe saw must never be used in the following cases:

- There is water or another liquid, explosive gases, or poisonous chemicals inside the pipe to be cut.
- The power switch is faulty.
- The power cable is faulty.
- The blade is bent.
- The blade is dull or in poor condition.
- The plastic components are cracked or have parts missing.
- The gripper unit is not properly tightened around the pipe or if it is warped.
- The blade guard cover or moving blade guard has been damaged or removed from the machine.
- The locking mechanisms do not work properly (UNLOCK - SWITCH).
- The pipe saw has become wet.

### When you use the saw, the following factors shall be considered:

- Support the pipes to be cut properly so that the blade is not clamped between the ends of the pipes.
- Support the pipe to cut securely. Pipe supports are more reliable for holding the pipe than bare hands.

- Make sure that the pipe to be cut is empty. Take care that no-one will put anything inside the pipe during the operation.
- Make sure that the diameter and thickness of the blade is suitable for the saw and that the blade is suitable for rotational speed selected.
- Do not use damaged or faulty blades or blade flanges. Blade flanges and nuts are custom made for this tool to ensure optimum operating performance and safety.
- Never use axial friction force to stop the blade, let it stop freely.
- Check the parts of the blade protection, never operate the tool if blade covers are not in place.
- Never apply excessive force when using the pipecut.
- Never use the pipecut to lift the pipe when fixed on the pipe.
- Avoid excessive load on the electric motor.
- Always wear a dust mask if cutting materials that produce dust, for example cast iron with Diamond blade.
- Always follow safety and operation manual and applicable regulations.

### Intended Use PipeCut 170E/220E

The Exact Pipe Cut 170E/220E is intended for professional use at any kind of construction sites.

The Exact PipeCut 170E/220E is designed to be used only for round pipes with diameter  
15 mm (0.6") - 170 mm (6") 170E  
15 mm (0.6") - 220 mm (8.6") 220E

The maximum wall thicknesses the Exact Pipe Cut 170E/220E can cut through is 8 mm (0.3") metal and 14mm (0.55") plastics.

With the Exact PipeCut P 400 you can cut pipes made from the different materials, such as steel, stainless steel, cast iron, copper, aluminium and plastic.

PipeCut 170E/220E pipe saw is intended for short, intermittent use. The machine may be loaded for 2,5 minutes during a 10-minute period (S3 25 %).

PipeCut 170E/220E pipe saw is not intended for use in industrial serial production.

## Exact PipeCut 170E/220E pipe cutting system operation instructions

### Before operating the tool

Ensure that the motor unit is in the upright position. The yellow mark of the UNLOCK button is visible.

Check that the blade is correctly fitted, in good condition and suitable for the material to be cut. Ensure the pipe saw guide wheels rotate. Ensure the support wheels rotate.

Check the operation of the lower blade guard. Ensure the pipe is empty.

If plastic pipes have been cut with the pipe saw (resulting in long, statically charged slivers), open the blade guard cover, and clean carefully the lower blade guard and the entire pipe saw.

### Connection to the mains power supply

Ensure that the mains voltage is the same as indicated on the rating plate (**Fig. A/14**). Connect the pipe saw to the power outlet only after having checked this.

### Precise setting of the cutting point

When you mark the cutting point on the pipe to be cut, deduct 20 mm or one inch on US models from the required dimension

Easy-to-remember rule: The cutting mark location requires a measurement of - 20 mm. (**Fig. C**)

### Setting the pipe on supports

Use the system supports when cutting pipes. This will ensure safe working and optimum result. Work on flat surface. Place the pipe on two supports so that the cutting point is between the supports. Place two more support under both ends of the pipe. Check that all support wheel contact the pipe (adjust if required e.g. with pieces of lumber) (**Fig. B**).

When cutting short pipes (25 cm or less) place the supports so that the cutting point is outside supports (**Fig. D**). Support the pipe with your left leg, if required. Proper arrangements will prevent the blade from jamming when the pipe is cut through.

Fig C

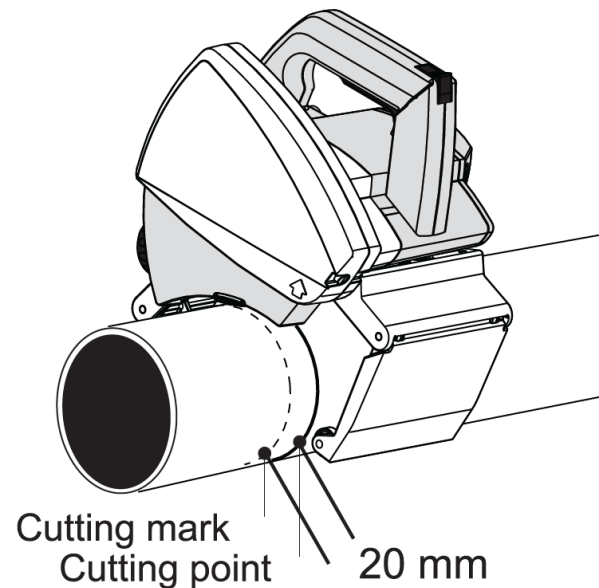

Fig D

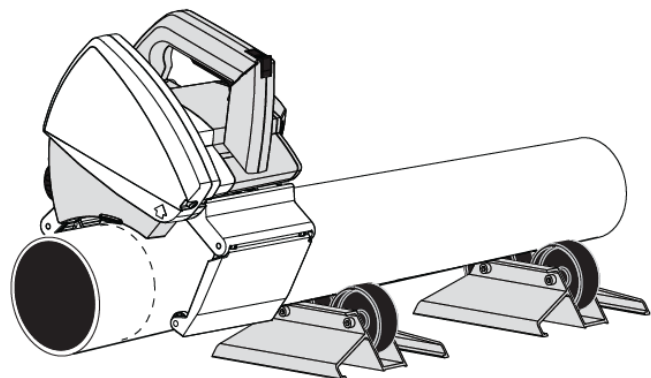
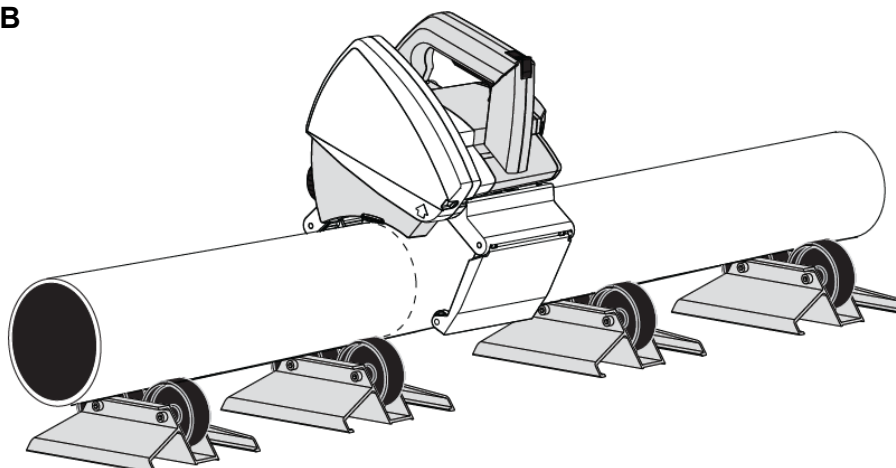

Fig B



### Attaching the pipe saw to the pipe

Open the pipe saw's gripper unit enough to suit the diameter of the pipe by rotating the adjustment handle located at the rear of the saw (**Fig. E/1**).

Position the pipe saw on top of the pipe so that the edge of the lower blade guard is at the cutting mark. Fasten the pipe saw to the pipe by turning the gripper adjustment handle until the gripper grips firmly the pipe to be cut (**Fig. E/2**). Hold the pipe in place and ensure that pipe saw moves freely in the direction the pipe is fed. For sake of safety ensure the pipe saw leads are to the left of the pipe saw. The pipe saw is now ready for cutting.

### Piercing the pipe wall

Grip the gripper firmly with your right hand and place your left foot on top of the pipe approximately 40cm from the pipe saw. Turn the saw until it leans slightly forward (**Fig. H**). When starting the motor, first of all release the power-switch locking lever (**Fig F/1**) and push the power switch all the way down (**Fig F/2**). Before starting to saw, wait until the blade reaches full speed. Pierce the pipe wall by pressing pipe saw operating handle downwards slowly and evenly until the blade has cut through the pipe wall (at this stage the pipe must not rotate) and the motor unit is locked in the sawing position (**Fig H/1**). Look at the UNLOCK button during the piercing operation. When UNLOCK button is locked, i.e. the yellow mark disappears (**Fig G**), pipe saw is locked in the sawing position, and you can safely start sawing around the pipe.

### Sawing around the pipe

Start sawing by feeding the pipe saw forward and fix the pipe with your left foot (**Fig H/3**). After that release the pipe (remove your left foot from the pipe) and turn the pipe saw backwards, whereby the pipe will also be rotated backwards (**Fig J**). Start a new feeding movement, and feed continuously forward ca. 1/6 of the pipe's circumference. Repeat until the pipe is cut off (**Fig K**).

Select the feeding speed as per the material and the thickness of the wall. Too high speed can damage the blade, overload the pipe saw and give a poor sawing result.

Fig. E

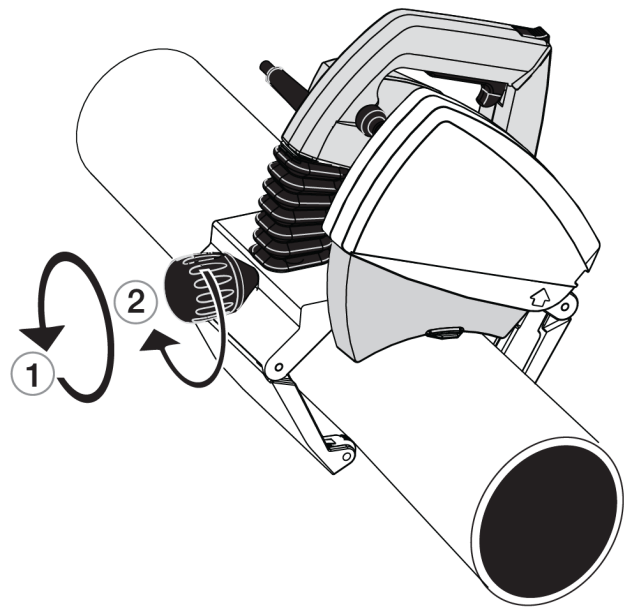

Fig. F

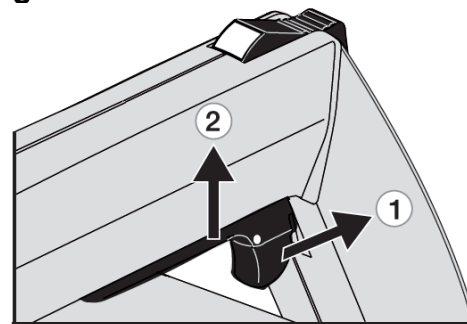

Fig. G

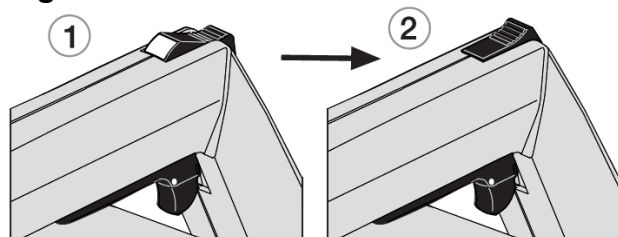
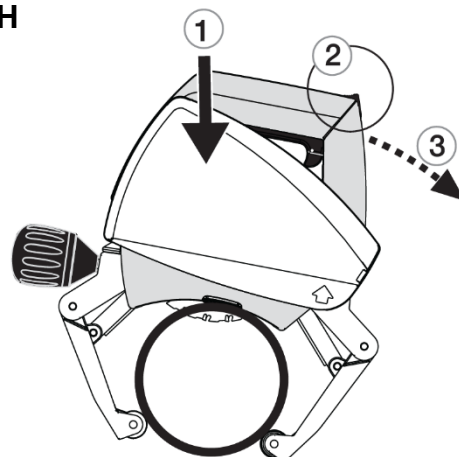

Fig. H



When the pipe is cut off, push the UNLOCK button forward until the yellow mark is visible and the locking is released (**Fig L/1**). Now raise the motor unit to starting post on (**Fig L/2**). Release the power switch (**Fig L/3**). When the blade is stationary, remove the pipe saw from the pipe by loosening the gripped handle (**Fig L/4**). Ensure that the moving lower blade-guard is lowered into safety position.

Should there be problems during piercing or sawing, abnormal sounds or vibrations due to which you have to interrupt sawing before the pipe is cut through, release the blade by pushing the UNLOCK button forward until the UNLOCK button is released, and lift the motor unit up. Once the problem is cleared, start sawing again.

Never start the motor, when the motor unit is locked in sawing position or teeth of the blade contact the pipe to be sawn.

### Overload protection and spin-speed regulator

There is a spin-speed regulator in models 170E and 220E. A suitable spin speed is selected, determined by the material to be sawn. There is also an automatic overload protection in the regulator.

In the case of overload: Release the power switch (**Fig L/3**). Push the UNLOCK button forward until the yellow mark is visible and the locking is released (**Fig L/1**). The electronics circuit limits the current and stops the motor. When the motor stops due the overload, the red light on the pipe cutter is turned on. The pipe cutter must cool down while the electronics dissipates the internal temperature. The motor will not start (even the red light turned off) until the switch is released and pressed once more time or plug disconnect and reconnect. The red light indicates to the user that the machine was overloaded.

The indicator light in question turns on for a moment every time the motor is started. This is normal and does not require any actions.

Fig. J

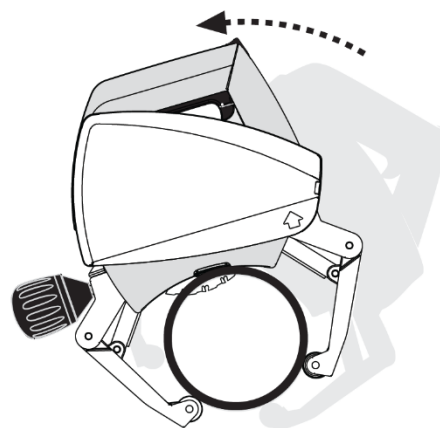

Fig. K

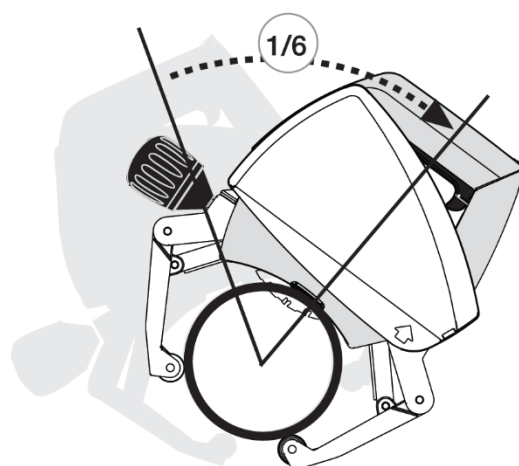
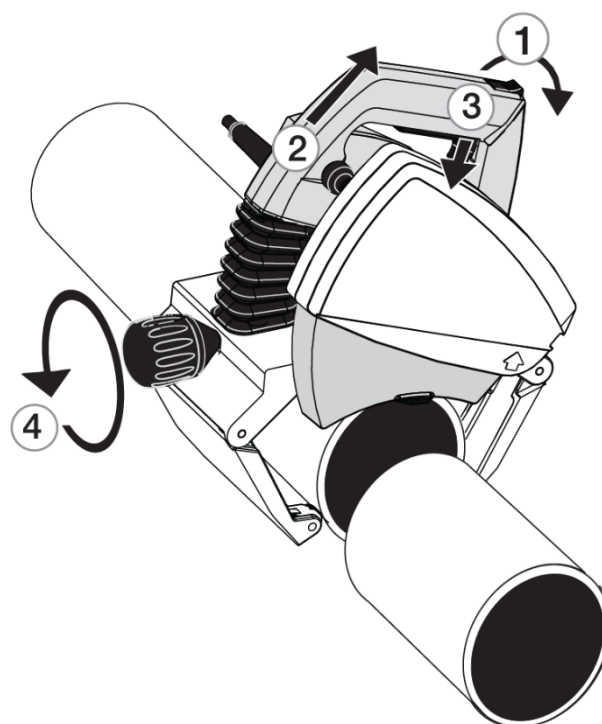

Fig. L



### Improving possible misalignment of the cut

The cut is affected by many factors, e.g. the size of the pipe, the material, the wall thickness, the quality of the pipe's surface, the roundness, welded seams, blade condition, feed rate, the operator's experience. The cutting result may vary and a gap may result on the cutting surface either to the right or left i.e. the difference between the start and end point of the cut (**Fig. M**).

There is a feature in the steering device of the Exact 170E/220E (**Fig. A/8**) which, if needed, can improve the sawing result.

Loosen the locking screw (**Fig.P/1**) with the M5 allen key on the handle of the Exact 170E/220E. There is an adjustment wheel on the right hand side of the steering device (**Fig. P/2**). Turn the wheel with your finger either clockwise or anti clockwise. The direction depends on the direction of the misalignment. This adjustment turns the entire motor unit in relation to the steering unit. There is also an arrow and a dial on the steering unit. (**Fig. P/2**) These will help to gauge the extent of the adjustment. Adjust the motor unit to the desired direction to correct the sawing error. The extent of the adjustment depends on the extent of the error, pipe diameter as well as the strength and material of the pipe wall. Tighten the locking screw (**Fig. P/1**) after the adjustment.

Fig. M

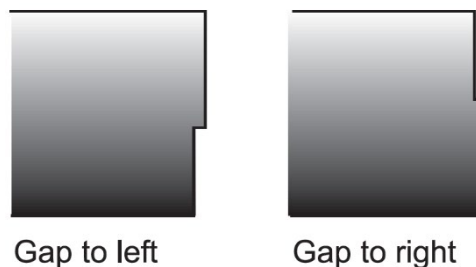

Fig. N

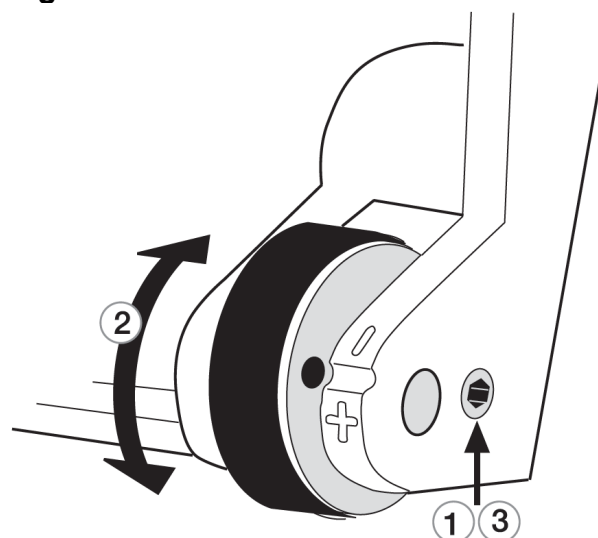

Fig. P

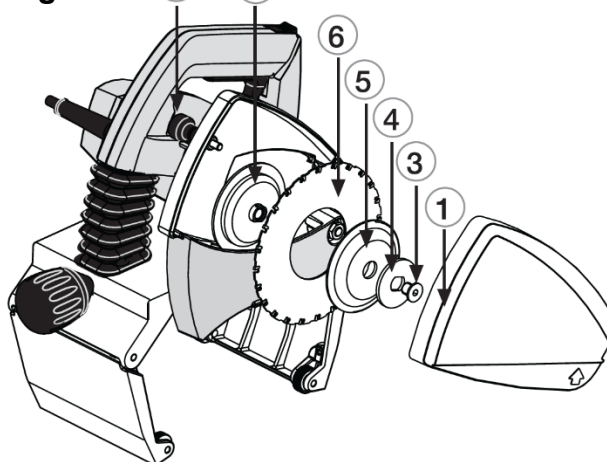
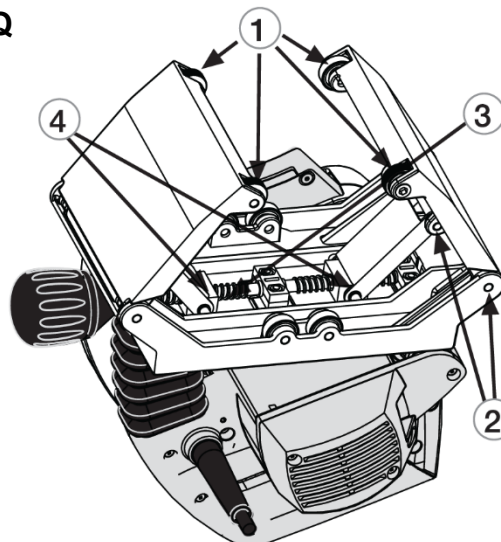

Fig. Q



### Installing and changing the saw blade

**⚠ WARNING: To reduce the risk of injury, turn unit off and disconnect it from power source before installing and removing accessories, before adjusting or when making repairs. An accidental start-up can cause injury.**

Remove the power plug from the socket. Check that the motor unit is locked in the upper position.

Remove the blade guard cover (**Fig. O/1**) by opening the screw (**Fig. O/2**). Press the spindle-lock button (**Fig. A/11**) and simultaneously rotate the blade by hand until the spindle-lock button drops a further distance. Now the rotation of the blade is prevented. Use the blade key to open the blade attachment bolt. Remove the securing bolt (**Fig. O/3**), the washer (**Fig.O/4**), the blade flange (**Fig. O/5**), and the blade (**Fig. O/6**).

Before installing a new blade, check that both blade flange discs are clean. Place a new or sharpened blade on the lower blade flange (**Fig. O/7**), so that the marked side of the blade is facing outwards and the arrows on the blade are facing in the same direction as the rotation direction markings on the inside of the blade case. Ensure that the new blade goes right to the bottom in the lower blade flange. Put the blade flange, the washer, and the securing bolt back in place. Press the spindle lock button and tighten the blade securing bolt. Put the blade guard cover back in place and tighten the screw.

## Maintenance and servicing instructions

Remove the power plug from the socket before servicing or cleaning the pipe saw. All maintenance operations carried out on the pipe saw's electrical components must be carried out by an approved service center or engineer.

### Blade

Check the condition of the blade. Replace a bent, blunt, or otherwise damaged blade with a new one. Using a blunt blade can overload the pipe saw's electric motor and gearbox. When you notice that the blade is blunt do not continue cutting with it, as the blade may become so badly damaged that it will not be worth sharpening. A blade in sufficiently good condition can be sharpened a few times by a professional sharpening company. Diamond X Discs cannot be sharpened

### Steering unit

Clean the steering unit regularly with compressed air and after each cut wipe out the chips with a brush.

### Blade guard

Make it a rule to clean the blade guard regularly and pay special attention to keep the moving blade guard movement from becoming obstructed.

### Motor

Keep motor air vents clean to allow free airflow.

### Plastic parts

Clean the plastic parts with a soft rag. Use only mild detergents. Do not use solvents or other strong detergents as they may damage the plastic parts and painted surfaces

### Power cable

Check the condition of the power cable regularly. A faulty power cable should always be replaced at an approved service center. Correct use and regular servicing and cleaning will ensure the reliable operation of the pipe saw.

## Environment



Separate collection. This product must not be disposed with normal household waste. When your Exact PipeCut machine is worn out, do not dispose it with normal household waste. This product must be recycled separately. Separate recycling of used products and packaging support recycling and recovery of materials. Reusing recycled materials helps preventing the pollution of the environment. According to local regulations it is possible to deliver household appliances to municipal rubbish depositories or to the dealer when purchasing a new product.

## Guarantee

### Warranty terms valid from 01.01.2018.

If the Exact PipeCut saw becomes unusable due to material or manufacturing defects within the Warranty Term, at our discretion we will repair the Exact PipeCut Saw or supply an entirely new or factory reconditioned Exact PipeCut Saw at no charge.

The Exact Tools Warranty Term is for 12 months from date of purchase.

The Warranty is only valid if:

- 1.) Copy of a dated purchase receipt is returned to the Authorized Warranty Repair Center or has been uploaded to our website at the time of warranty registration.
- 2.) The Exact PipeCut Saw has not been misused.
- 3.) No attempt has been made by non-approved persons to repair the saw.
- 4.) The Exact PipeCut Saw has been used in accordance with the operating, safety, and servicing instructions provide in these instructions.
- 5.) The Exact PipeCut Saw has been delivered to an Authorized Warranty Repair Center within the warranty period.

**NOTICE! The Exact PipeCut Saw is to be shipped to the Authorized Warranty Repair Center freight prepaid. If the Exact PipeCut Saw is repaired under Warranty, the return shipment will be made freight prepaid.**

### CAUTION!

The following items or services are excluded for Warranty claims:

- Saw blades
- Carbon brushes
- Blade or attachment flange
- Blade attachment nut
- Normal wear
- Failures caused by misuse or accident
- Water, fire or physical damage
- Cables
- Adjustment of eccentric adjustment wheel
- If a wrong type of generator has been used as power source.

## Tips for using Exact PipeCut Saws

All these tips may not concern all Exact models

Diamond blades can only be used for cutting cast or ductile iron pipes. This pipe material is not recommended to cut using to a blade of any other type.

Clean the inside of the blade guards after cutting plastic pipes.

Smaller pipes are easier to cut by turning the pipe manually either on the table or on the floor.

**CAUTION!** Turn the pipe towards yourself when you do it manually. Don't turn the pipe too fast.

Check the condition of the blade regularly.

The cutting process is divided into two stages: first you need to cut through the pipe wall and then cut around the pipe.

Do not overload the saw while working without interruption. The pipecut will overheat and metal parts can become very hot. In this case, the motor and blade may become damaged. Use the pipecut system in accordance with its duty cycle being continuous cutting 2.5 minutes, then let it cool under no load for 7.5 minutes.

Maintain a uniform feed rate. This increases the lifespan of the blade. For example, a steel pipe with an outer diameter of 170 mm (6") and wall thickness of 5 mm (1/5"), the cutting time-is 15-20 seconds. Accordingly cast iron pipe with an outer diameter of 4" (110 mm) and wall thickness of 1/6" (4 mm), the cutting time is 20 – 25 seconds.

When not cutting, keep the motor unit in the up position. Never place the tool on the pipe with motor unit in locked down / cutting position.

**Due to continuous product development, the information in this instruction book may change. We do not give separate notification of changes.**

# **exact**

**Exact Tools Oy Martinkyläntie 41  
FI-01720 Vantaa**

**Finland Tel +358 9 4366750**

**[exact@exacttools.com](mailto:exact@exacttools.com)**

**[www.exacttools.com](http://www.exacttools.com)**