

PipeCut Infinity

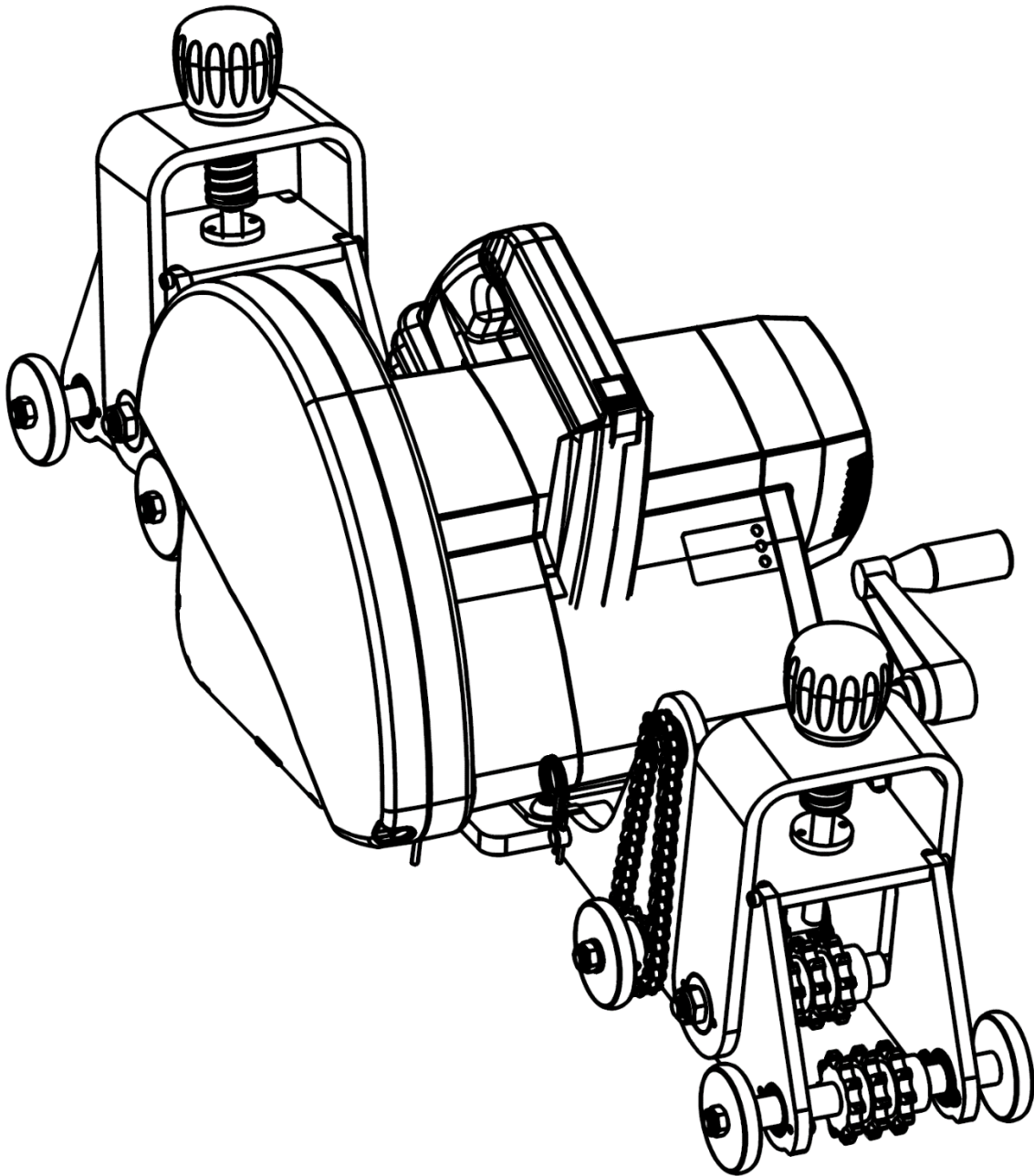

These are the original instructions.

All instructions are available on web-site: exacttools.com/manuals

Intentionally left blank

Exact PipeCut Infinity

Data of Exact PipeCut saw blades

1. Exact TCT saw blades are for cutting steel, copper, aluminum and all kind of plastics pipe materials. Exact TCT saw blades can be sharpened.
2. Exact CERMET saw blades are for cutting stainless steel, acid proof materials, steel, copper, aluminum and all kind of plastic pipe materials. Exact CERMET saw blades can be sharpened.
3. Exact CERMET ALU saw blades are for cutting all kind of aluminum and plastic pipe materials. Exact CERMET ALU saw blades can be sharpened.
4. Exact TCT P blades are for cutting all kind of plastic pipe materials. Exact TCT P saw blades can be sharpened.
5. Exact DIAMOND X discs are for cutting Cast or Ductile Iron only. Exact DIAMOND X discs cannot be sharpened.

Declaration of Conformity

We declare under our sole responsibility that the pipe cutting machines Exact PipeCut Infinity Described under "Technical Data" are in conformity with the following standards or standardization documents:

EN 62841-1:2015, EN 55014-1:2017, EN 55014-2:2015, EN 61000-3-2:2018,
EN 61000-3-3:2002

according to the technical provisions of the directives 2006/42/EC and 2014/30/EU

For more information, please contact Exact Tools at the address below.

The technical file is available at the address underneath

The person authorized to compile the technical file:

Marko Törrönen, R&D Manager, Exact Tools Oy (marko.torronen@exacttools.com)

Helsinki, 08.02.2022



Seppo Makkonen
Chairman of the Board
Exact Tools Oy
Martinkyläntie 41
FI-01720 Vantaa
Finland

FIGURE A

- 1 Unlocking switch
- 2 Power switch
- 3 Power switch locking lever (in front of the switch)
- 4 Blade guard cover
- 5 Overload indicator lights
- 6 Moving blade-guard
- 7 Motor unit adjusting screws
- 8 Front tensioner with drive
- 9 Rear tensioner
- 10 Handle
- 11 Blade guard screw
- 12 Blade lock pin
- 13 Rating plate
- 14 Motor unit
- 15 Blade RPM selector switch
- 16 Motor unit adjustment indicator
- 17 Tensioner tightening knobs
- 18 Quick release axles
- 19 Drive handle
- 20 Cutting depth adjusting wheel

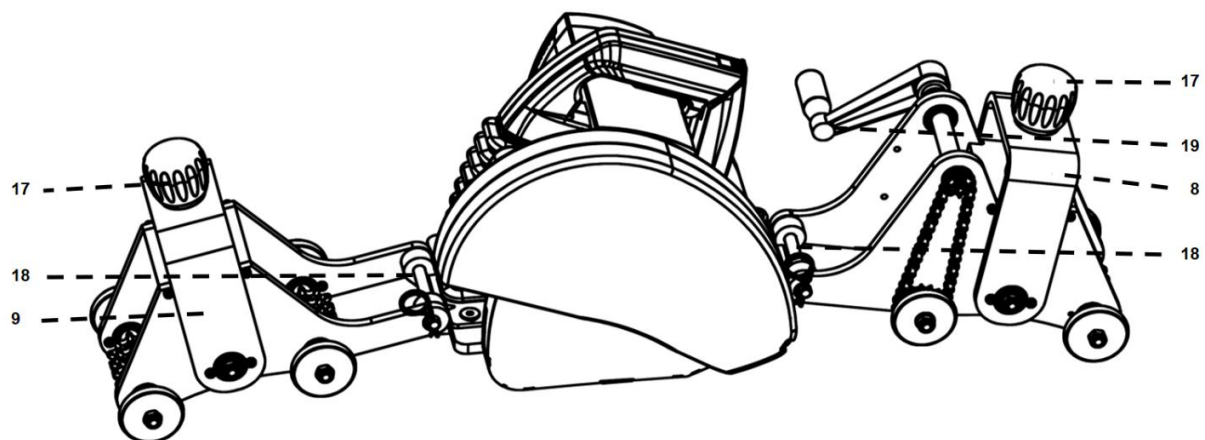
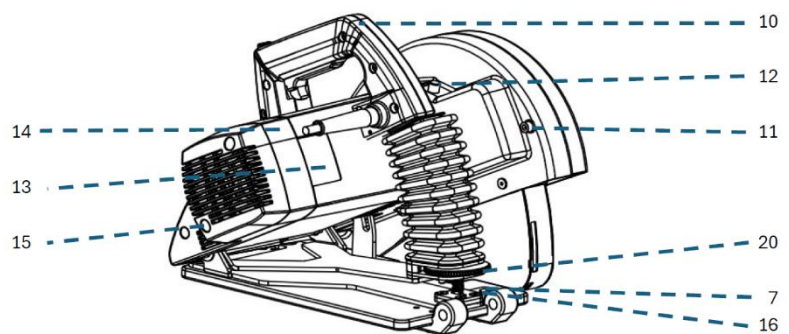
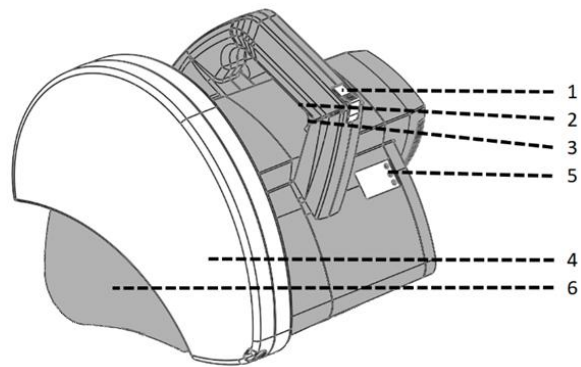

Contents**Information**

Technical data	5
Package contents	5

Safety

Safety instructions	6
---------------------	---

Operation

Functional description	9
Product features	9
Before operating the tool	10
Connection to mains power supply	10
Setting the pipe on supports	10
Attaching the pipe saw to the pipe	10
Piercing the pipe wall	11
Cutting around the pipe	11
Overload protection and RPM adjustment	13
Explanation if indicator lights	13
Error code display	13
Cutting result adjustment on Exact PipeCut Infinity	14
Using the cutting depth adjustment	15
Installing and changing the blade	16
Maintenance and servicing instructions	16
Environment / disposal	17
Guarantee / guarantee conditions	17
Tips for using Exact PipeCut saws	17
Extra equipment	18
Theoretical maximum cutting depths	20

Exact PipeCut Infinity pipe saw

Voltage	220 V– 240 V or 100 V–130 V, all 50–60Hz
Power	2500 W– 220 V– 240 V or 15 A-100 V– 130 V
No-load speed	I (low) = 1900/min, II (high) = 2885 /min
Blade diameter	140 mm (5.6"), 165 mm (6.50"), 180 mm (7.2"), 190 mm (7.6")
Mounting bore	62 mm (2.44")
Range of use	460 mm – 3000 mm / 18"-120"
Max. pipe wall, plastics and other soft materials	43 mm / 1.7"
Max. Pipe wall 230V, steel, iron	20 mm / 0.78"
Max. Pipe wall 120V, steel, iron	12 mm / 0.5"
Protection class	IP / II
Spindle lock	Yes
Speed preselection	Yes
Constant electronic control	Yes
Overload Protection	Yes
Reduced starting current	Yes
Recommended generator capacity	4,9kVA for 230V, 3kVA for 100 V-120V

The values given are valid for nominal voltages [U] of 230 V. For lower voltage and models for specific countries, these values can vary.

Exact PipeCut Infinity pipe cutting systems

Package contents, please check that the package contains the following items:

- Exact PipeCut System Shoulder Bags, 2pcs
- Exact PipeCut Infinity motor unit with blade installed
- Tensioner device
- Tensioner device with crank
- Attachment chain segments, for pipe outer diameter up to 1850mm:
 - 2 m 2 pcs
 - 1 m 1 pc
 - 0,5 m 1pc
 - 0,2 m 2pcs
 - 0,1 m 1pc
- Chain selection chart for different pipe outer dimensions
- Operating instructions
- Allen key 5 mm attached to saw

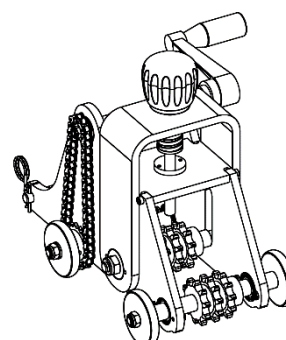
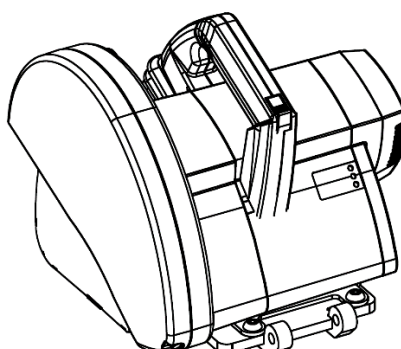
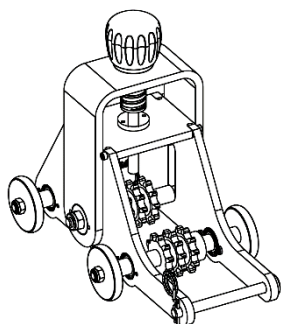
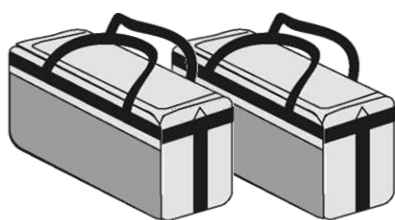



Definitions: Safety instructions

The definitions below describe the level of severity for each signal word. Please read the manual and pay attention to these symbols

 **DANGER:** Indicates an imminently hazardous situation which, if not avoided, will result in serious injury or in extreme cases a fatality

 **WARNING:** Indicates a potentially hazardous situation which, if not avoided, could result in serious injury or in extreme cases a fatality

 **CAUTION:** Indicates a potentially hazardous situation which, if not avoided, may result in minor or moderate injury.

 **NOTICE:** Indicates a practice not related to personal injury which, if not avoided, may result in property damage.

 **Denotes risk of electric shock.**

Symbols found on the machine.

 **Use ear protection.**

 **Use gloves.**

 **Read instructions before use.**

 **Laser radiation:** Do not look directly into beam.



Saw blade: Saw blade behind this cover, do not insert fingers or other body parts inside this cover.

Operating, safety and service instructions

Read these operating, safety and service instructions carefully before operating the pipe saw.

Store these instructions in a place where all pipe saw operators have access. In addition to these instructions official work, health and safety rules must be followed. Exact PipeCut is for professional use only.

Please notice the article number on the type plate of your machine. The trade names of the individual machines may vary.

Only for power tools without reduced starting current: Starting cycles generate brief voltage drops. Interference with other equipment/machines may occur in case of unfavorable mains system conditions. Malfunctions are not to be expected for system impedances below 0.36 ohm.

Use ear protection!

 **WARNING:**

If Pipecut Exact PipeCut Infinity tool is used with generator or extension cords, their minimum requirements are as follows:

Generator: minimum power of 4,9kVA for 230V, 3kVA for 100 V-120V, if other electrical equipment is not used at the same time.

Extension cords 230 V: The maximum length - 25 meters. Cable cross section - not less than 2,5mm².

Extension cords 120 V: The maximum length – 82 Feet Extra Heavy Duty

General power tool safety warnings



WARNING: Read all safety warnings, illustrations and specifications provided with this power tool. Failure to follow all instructions listed below may result in electric shock, fire and/or serious injury

Save all warnings and instructions for future reference.

The term "power tool" in the warnings refers to your mains operated (corded) power tool or battery-operated (cordless) power tool.

1 Work area safety

- a) **Keep work area clean and well lit.** Cluttered or dark areas invite accidents.
- b) **Do not operate power tools in explosive atmospheres, such as in the presence of flammable liquids, gases or dust.** Power tools create sparks which may ignite the dust or fumes.
- c) **Keep children and bystanders away while operating a power tool.** Distractions can cause you to lose control.

2 Electrical safety

- a) **Power tool plugs must match the outlet. Never modify the plug in any way. Do not use any adapter plugs with earthed (grounded) power tools.** Unmodified plugs and matching outlets will reduce risk of electric shock.
- b) **Avoid body contact with earthed or grounded surfaces, such as pipes, radiators, ranges and refrigerators.** There is an increased risk of electric shock if your body is earthed or grounded.
- c) **Do not expose power tools to rain or wet conditions.** Water entering a power tool will increase the risk of electric shock
- d) **Do not abuse the cord. Never use the cord for carrying, pulling or unplugging the power tool. Keep cord away from heat, oil, sharp edges or moving parts.** Damaged or entangled cords increase the risk of electric shock
- e) **When operating a power tool outdoors, use an extension cord suitable for outdoor use.** Use of a cord suitable for outdoor use reduces the risk of electric shock.
- f) **If operating a power tool in a damp location is unavoidable, use a residual current device (RCD) protected supply.** Use of an RCD reduces the risk of electric shock

3 Personal safety

- a) **Stay alert, watch what you are doing and use common sense when operating a power tool. Do not use a power tool while you are tired or under the influence of drugs, alcohol or medication.** A moment of inattention while operating power tools may result in serious personal injury.
- b). **Use personal protective equipment. Always wear eye protection.** Protective equipment such as

dust mask, non-skid safety shoes, hard hat, or hearing protection used for appropriate conditions will reduce personal injuries.

- c) **Prevent unintentional starting. Ensure the switch is in the off-position before connecting to power source and/or battery pack, picking up or carrying the tool.** Carrying power tools with your finger on the switch or energizing power tools that have the switch on invites accidents.
- d) **Remove any adjusting key or wrench before turning the power tool on.** A wrench or a key left attached to a rotating part of the power tool may result in personal injury.
- e) **Do not overreach. Keep proper footing and balance at all times.** This enables better control of the power tool in unexpected situations.
- f) **Dress properly. Do not wear loose clothing or jewelry. Keep your hair and clothing away from moving parts.** Loose clothes, jewelry or long hair can be caught in moving parts.
- g) **If devices are provided for the connection of dust extraction and collection facilities, ensure these are connected and properly used.** Use of dust collection can reduce dust-related hazards.
- h) **Do not let familiarity gained from frequent use of tools allow you to become complacent and ignore tool safety principles.** A careless action can cause severe injury within a fraction of a second.

4 Power tool use and care

- a) **Do not force the power tool. Use the correct power tool for your application.** The correct power tool will do the job better and safer at the rate for which it was designed.
- b) **Do not use the power tool if the switch does not turn it on and off.** Any power tool that cannot be controlled with the switch is dangerous and must be repaired.
- c) **Disconnect the plug from the power source and/or remove the battery pack, if detachable, from the power tool before making any adjustments, changing accessories, or storing power tools.** Such preventive safety measures reduce the risk of starting the power tool accidentally.
- d) **Store idle power tools out of the reach of children and do not allow persons unfamiliar with the power tool or these instructions to operate the power tool.** Power tools are dangerous in the hands of untrained users.
- e) **Maintain power tools and accessories. Check for misalignment or binding of moving parts, breakage of parts and any other condition that may affect the power tool's operation. If damaged, have the power tool repaired before use.** Many accidents are caused by poorly maintained power tools.
- f) **Keep cutting tools sharp and clean.** Properly maintained cutting tools with sharp cutting edges are less likely to bind and are easier to control.
- g) **Use the power tool, accessories and tool bits etc. in accordance with these instructions, taking into account the working conditions and the work to be performed.** Use of the power tool for operations

different from those intended could result in a hazardous situation.

h) **Keep handles and grasping surfaces dry, clean and free from oil and grease.** Slippery handles and grasping surfaces do not allow for safe handling and control of the tool in unexpected situations.

5 Service

a) **Have your power tool serviced by a qualified repair center using only identical replacement parts.** This will ensure that the safety of the power tool is maintained.

Cutting procedures

a)  **DANGER: Keep hands away from cutting area and the blade. Keep your second hand on auxiliary handle, or motor housing.** If both hands are holding the saw, they cannot be cut by the blade.

b) **Do not reach underneath the workpiece.** The guard cannot protect you from the blade below the workpiece.

c) **Adjust the cutting depth to the thickness of the workpiece.** Less than a full tooth of the blade teeth should be visible below the workpiece.

d) **Never hold the workpiece in your hands or across your leg while cutting. Secure the workpiece to a stable platform.** It is important to support the work properly to minimize body exposure, blade binding, or loss of control.

e) **Hold the power tool by insulated gripping surfaces, when performing an operation where the cutting tool may contact hidden wiring or its own cord.** Contact with a "live" wire will also make exposed metal parts of the power tool "live" and could give the operator an electric shock.

f) **When ripping, always use a rip fence or straight edge guide.** This improves the accuracy of cut and reduces the chance of blade binding.

g) **Always use blades with correct size and shape (diamond versus round) of arbour holes.** Blades that do not match the mounting hardware of the saw will run off-centre, causing loss of control.

h) **Never use damaged or incorrect blade washers or bolt.** The blade washers and bolt were specially designed for your saw, for optimum performance and safety of operation.

Further safety instructions

Kickback causes and related warnings

– kickback is a sudden reaction to a pinched, jammed or misaligned saw blade, causing an uncontrolled saw to lift up and out of the workpiece toward the operator;

– when the blade is pinched or jammed tightly by the kerf closing down, the blade stalls and the motor reaction drives the unit rapidly back toward the operator;

– if the blade becomes twisted or misaligned in the cut, the teeth at the back edge of the blade can dig into the top surface of the wood causing the blade to climb out of the kerf and jump back toward the operator.

Kickback is the result of saw misuse and/or incorrect operating procedures or conditions and can be avoided by taking proper precautions as given below.

a) **Maintain a firm grip with both hands on the saw and position your arms to resist kickback forces. Position your body to either side of the blade, but not in line with the blade.** Kickback could cause the saw to jump backwards, but kickback forces can be controlled by the operator, if proper precautions are taken.

b) **When blade is binding, or when interrupting a cut for any reason, release the trigger and hold the saw motionless in the material until the blade comes to a complete stop. Never attempt to remove the saw from the work or pull the saw backward while the blade is in motion or kickback may occur.** Investigate and take corrective actions to eliminate the cause of blade binding.

c) **When restarting a saw in the workpiece, centre the saw blade in the kerf so that the saw teeth are not engaged into the material.** If a saw blade binds, it may walk up or kickback from the workpiece as the saw is restarted.

d) **Support large panels to minimise the risk of blade pinching and kickback.** Large panels tend to sag under their own weight. Supports must be placed under the panel on both sides, near the line of cut and near the edge of the panel.

e) **Do not use dull or damaged blades.** Unsharpened or improperly set blades produce narrow kerf causing excessive friction, blade binding and kickback.

f) **Blade depth and bevel adjusting locking levers must be tight and secure before making the cut.** If blade adjustment shifts while cutting, it may cause binding and kickback.

g) **Use extra caution when sawing into existing walls or other blind areas.** The protruding blade may cut objects that can cause kickback.

Guard function

a) **Check the guard for proper closing before each use. Do not operate the saw if the guard does not move freely and enclose the blade instantly. Never clamp or tie the guard so that the blade is exposed.**

If the saw is accidentally dropped, the guard may be bent. Check to make sure it moves freely and does not touch the blade or any other part, in all angles and depths of cut.

b) **Check the operation of the guard spring. If the guard and the spring are not operating properly, they must be serviced before use.** The guard may operate sluggishly due to damaged parts, gummy deposits, or a build-up of debris.

c) **Assure that the base plate of the saw will not shift while performing a "plunge cut".** Blade shifting sideways will cause binding and likely kick back.

d) **Always observe that the guard is covering the blade before placing the saw down on bench or floor.** An unprotected, coasting blade will cause the saw to walk backwards, cutting whatever is in its path. Be aware of the time it takes for the blade to stop after the switch is released.

The pipe saw must never be used in the following cases:

- There is water or another liquid, explosive gases, or poisonous chemicals inside the pipe to be cut.
- The power switch is faulty.
- The power cable is faulty.
- The blade is bent.
- The blade is dull or in poor condition.
- The plastic components are cracked or have parts missing.
- The blade guard cover or moving blade guard has been damaged or removed from the machine.
- The locking mechanisms do not work properly (UNLOCK - SWITCH).
- The pipe saw has become wet.

When you use the saw, the following factors shall be considered:

- Support the pipes to be cut properly so that the blade is not clamped between the ends of the pipes.
- Support the pipe to cut securely. Pipe supports are more reliable for holding the pipe than bare hands.
- Make sure that the pipe to be cut is empty. Take care that no-one will put anything inside the pipe during the operation.
- Make sure that the diameter and thickness of the blade is suitable for the saw and that the blade is suitable for rotational speed selected
- Do not use damaged or faulty blades or blade flanges. Blade flanges and nuts are custom made for this tool to ensure optimum operating performance and safety.
- Never use axial friction force to stop the blade, let it stop freely.
- Check the parts of the blade protection, never operate the tool if blade covers are not in place.
- Never apply excessive force when using the pipecut.

- Never use the pipecut to lift the pipe when fixed on the pipe.
- Avoid excessive load on the electric motor.
- Always wear a dust mask if cutting materials that produce dust, for example cast iron with Diamond blade.
- Always follow safety and operation manual and applicable regulations.

Intended Use

PipeCut Infinity

PipeCut Infinity pipe saw is intended for use as a pipe fitter's tool at the job site.

PipeCut Infinity can only be used to cut round pipes, with a diameter of 460mm – 3000mm (18"– 120")

PipeCut Infinity can be used to cut pipes with greater diameter if additional chain sections are used. Chain delivered with the PipeCut Infinity works on pipes with diameter up to 1850mm.

Maximum wall thicknesses:

Steel	20 mm (0,78")	230V / 0.5" (12mm) 120V
Plastic	50 mm (2.0")	

PipeCut Infinity pipe saw can be used to cut all normal pipe materials, such as steel, stainless steel, cast/ductile iron, copper, aluminum and plastic. When cutting different materials, always use appropriate blade.

See the cutting depth table on the back cover.

PipeCut Infinity pipe saw is not intended for use in industrial production.

Use only blades within the diameter range stated in technical data.

Do not use any abrasive wheels.

Do not use any blade with lower speed marking than no-load speed marked on the power tool.

Use pipe holders to support the pipe being cut.

With additional accessories PipeCut Infinity can also be used for simultaneous cutting and beveling of cast or ductile iron pipes. See page 19 for more information.

Exact PipeCut Infinity pipe cutting system operation instructions

Before operating the tool

- Ensure that motor unit is in the upright position.
- Check that the blade is correctly fitted, in good condition and suitable for the material to be cut.
- Ensure all the wheels rotate.
- Check the operation of the lower blade guard.
- Ensure the pipe is empty.

Setting the pipe on supports

As the saw needs to go around the pipe, the pipe needs to be supported above ground. Minimum recommended clearance to obstacles is 300mm for the crank to be accessible (Fig B).

Make sure that the pipe is supported well and it remains stationary even after the cut.

⚠ WARNING: Be sure to support the pipe on at least two places on both sides of the cut. Failure to support the pipe halves correctly can lead to personal injury and/or damage to equipment.

If you only cut a short section of the pipe, for example to straighten the end, take care of the cut section falling off when the cut is completed. In these cases, always start the cut from the top of the pipe to avoid injury.

Attaching the pipe saw to the pipe

Assemble the Infinity. (Fig C)

- Attach the carrier with the crank in the front of the motor unit. Use the supplied quick release axles for the connection and lock it in place with the locking pin.
- Attach the carrier without the crank behind the motor unit. Use the supplied rod and lock it in place with the pin.

Select correct chain pieces according to the supplied table and join them together.

- Adjust the tension sprockets to their lowest position.
- Route the chain through carrier as in the picture (FIGURE C1), over the center sprocket and under wheel axles. Do this for both carriers.
- Position the saw on top of the pipe and connect the chain ends together.
- Align the chain to follow the cutting line. Cutting line is 90mm from the side of the chain.
- Tighten the chain with the help of both tensioners. Turn the tightening knobs clockwise (FIGURE C2).
- When the chain is tight, circle the saw around the pipe at least once by turning the crank. This will straighten the chain.
- Re-tighten the chain if it came loose.
- Repeat the two previous steps if needed.

Connection to the mains power supply

Ensure that the mains voltage is the same as indicated on the rating plate (FIGURE A / 13). Connect the pipe saw to the power outlet only after having checked the above points first.

FIGURE B

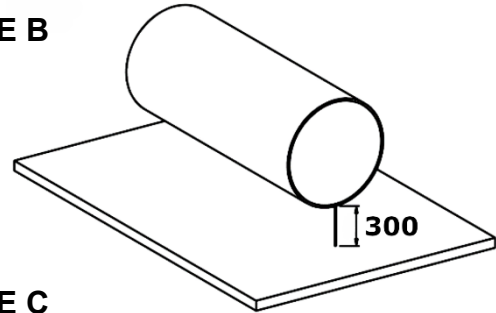

FIGURE C

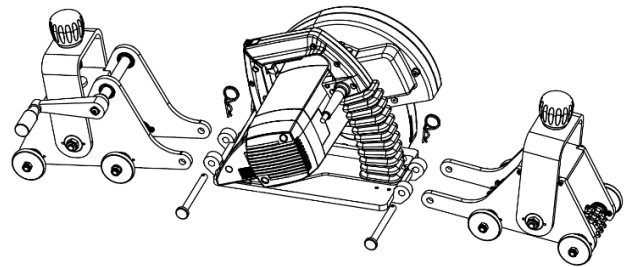

FIGURE C1

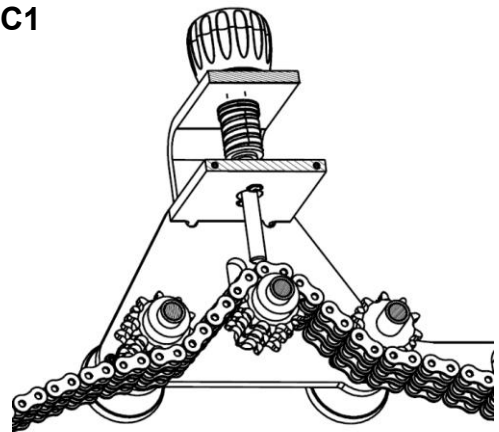
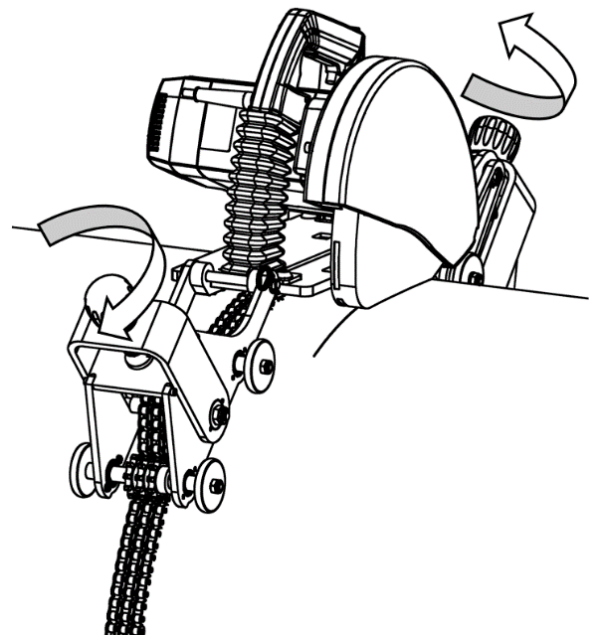

FIGURE C2



Piercing the pipe wall

To start the motor, release the power-switch locking lever first (FIGURE D / 1) and push the power switch all the way in (FIGURE D / 2). The power switch can be locked to ON position by pushing the yellow trigger forwards before releasing the power switch (FIGURE D / 1).

To stop the motor, push the power switch all the way in to release the power switch locking lever (FIGURE D / 2).

Before starting to cut, wait until the blade reaches full speed.

Pierce the pipe wall by pressing pipe saw operating handle towards the pipe slowly and steadily until the blade has cut through the pipe wall (FIGURE F / 1).

Look at the UNLOCK SWITCH during the piercing operation. The yellow mark on the UNLOCK SWITCH disappears when the pipe saw is locked in the sawing position (FIGURE E / 1-2).

After the motor unit is locked in the sawing position (FIGURE F / 1) and you can safely start cutting around the pipe.

Cutting around the pipe

Start cutting by turning the crank forwards (FIGURE F / 2).

Do this at a steady speed and start with low rate. Pay attention to traffic lights to reach the best feed rate and avoid overloading the motor. The best cutting result and blade life is at the edge of green light turning into blinking yellow.

- If the yellow starts to blink, slow down the feed rate.
- If the green light is on, speed up the feed rate.

Do not leave the saw standing steady and motor running with the blade in contact with the pipe. This will heat up the blade and cause loss of cutting performance and blade life.

If the traffic lights start to blink red, the motor has overheated. Follow the below steps:

- Stop cutting and raise the motor unit into up position (FIGURE G).
- Let the motor run in free running mode to cool the motor.
- Wait for the green light to come on.
- Push the motor unit down and lock it back to sawing position.
- Continue to cut

FIGURE D

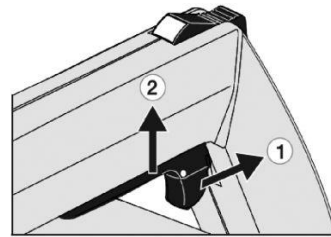

FIGURE E

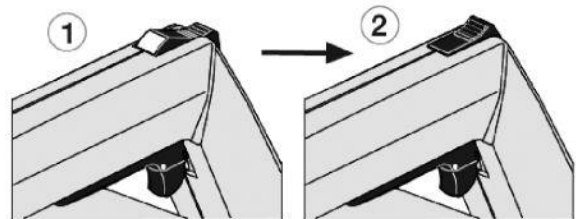

FIGURE F

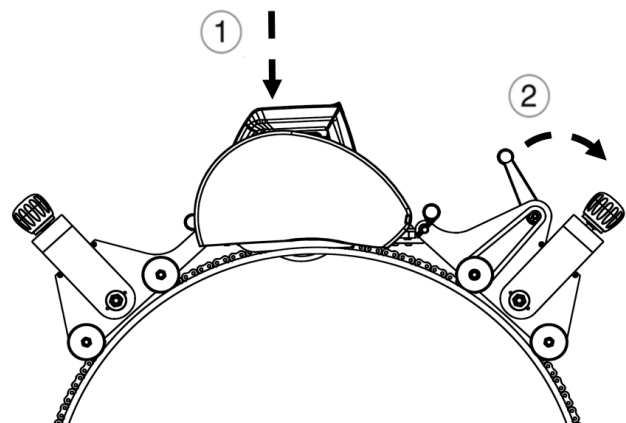
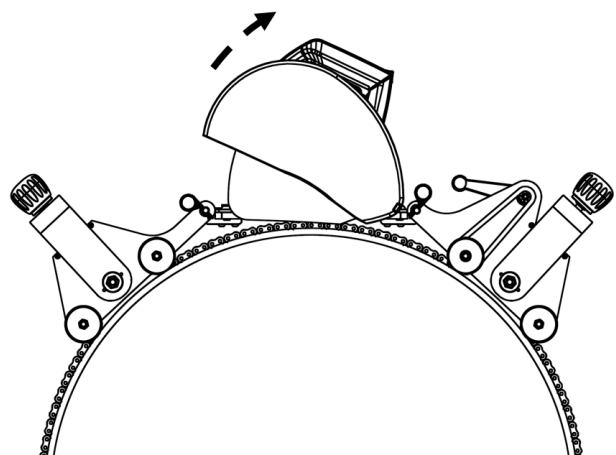

FIGURE G



When the pipe is cut off, push the UNLOCK SWITCH forward until the yellow mark is visible and the locking is released (FIGURE H 1 / 2).

Raise the motor unit to starting position (FIGURE I / 1). Release the power switch locking by pushing the power switch fully in and then releasing it. (FIGURE I / 2). Ensure that the moving lower blade-guard is lowered into down position.

When the blade has stopped, loosen the chain by turning the tightening knobs counterclockwise.

Cut the chain into separate pieces by removing the attachment pins.

Should there be problems during piercing or cutting; abnormal sounds or vibrations or you must interrupt cutting before the pipe is cut, release the motor unit locking by pushing the UNLOCK SWITCH forward until the locking is released and lift the motor unit up. Once the problem is cleared, start cutting again.

Never start the motor when it is locked in sawing position, or the teeth of the blade are in contact with the pipe to be sawn.

FIGURE H

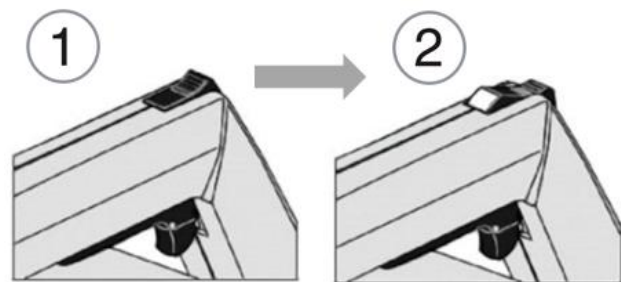
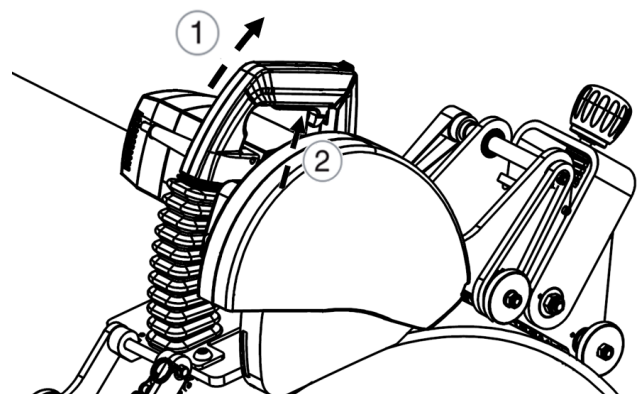

FIGURE I



RPM selector and Overload protector

The saw has a two-speed blade RPM speed control (FIGURE A / 15). When cutting stainless or acid-proof steel use the lower RPM setting I. When cutting other materials use the faster RPM setting II.

The saw also has an overload protector which displays electric motor loading with three indicator lights (FIGURE A / 5).

Explanation of indicator lights (FIGURE J)

Normal operation	Green: ON Yellow: OFF Red: OFF
Normal power output	Green: OFF Yellow: OFF Red: OFF
Motor temperature high WARNING	Green: OFF Yellow: Blinking Red: OFF
Normal power output	Green: OFF Yellow: Blinking Red: OFF
Motor current high WARNING	Green: OFF Yellow: Blinking Red: OFF
Decreasing power output	Green: OFF Yellow: OFF Red: OFF
Motor temperature protection active	Green: OFF Yellow: OFF Red: Blinking
Power output very low, only cooling with free running	Green: OFF Yellow: OFF Red: Blinking
Temperature sensor faulty	Green: OFF Yellow: ON Red: OFF
Power output low to finish the work	Green: OFF Yellow: ON Red: OFF

GREEN If green light is on, the motor temperature and power output are normal.

➔ **Continue using the tool.**

YELLOW If yellow light begins to flash, the motor is hot and/or overloaded.

➔ **Slow down the cutting speed**
(It is possible, that you are using a worn-out blade)

RED If the red light begins to flash, motor power is automatically reduced to the minimum to protect the motor. Cutting is not possible.

➔ **Press the motor switch and let it run freely (UNDER NO LOAD) until the green light is on.**

ATTENTION!

If the yellow light turns on continuously, it indicates that the motor control unit has been damaged. You can finish the sawing, but the saw should be taken to service. If the motor control unit is not repaired, the motor of the saw will get damaged.

FIGURE J

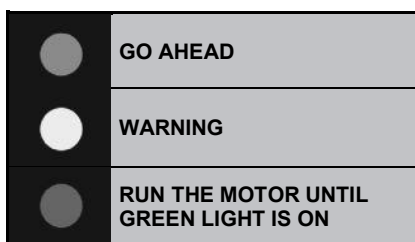

Error code display

If the electronic control unit senses a problem situation, it will give an error code indicating the fault. This error code is given by blinking the green light.

Code will consist of blinks followed by a short pause. Longer pause is kept between the codes. To be able to read the codes, the main switch needs to be kept connected.

List of error codes can be found below.

No. of blinks	Error description
1	Mains frequency too high
2	Mains frequency too low
3	Mains voltage malformed
4	Mains voltage too high
5	Internal reference error
6	Current too high or too low during soft-start
7	No speed signal during soft-start
8	Speed sensor open during soft-start
9	Speed sensor signal invalid during soft-start
10	Motor overload during operation
11	Motor overload during cooling free run
12	Motor overload during temperature sensor error
13	No speed signal during operation
14	Speed sensor open during operation
15	Speed sensor signal invalid during operation

Cutting result adjustment on Exact PipeCut Infinity

The cut is affected by many factors, for example the size of the pipe, material, wall thickness, quality of the pipe's surface, roundness, welded seams, blade condition, feed rate, operator's experience. For these reasons, the saw may move to left or right causing unperfect cut (see FIGURE K).

Infinity is heavily guided by the chain attaching the saw to the pipe. It is important to place the chain correctly and parallel to the pipe centerline. Rotating the saw around the pipe before cutting helps to align the chain.

If the cutting result is still not square, blade alignment can be adjusted.

Adjusting the alignment of the blade

CAUTION! Blade alignment adjustment is very effective and can lead to blade and/or saw damage if adjusted too much.

Before making the adjustment, note the bodyplate alignment in case it is needed to return back to the original setting.

Loosen the two screws securing the bodyplate (FIGURE L). Turn the bodyplate to the required direction and tighten the two screws. Make only small adjustments at a time.

If the cutting line goes from right to left (FIGURE K/a), turn the bodyplate clockwise (FIGURE N / 1).

If the cutting line goes from left to right (FIGURE K/b), turn the bodyplate counterclockwise (FIGURE N / 2).

CAUTION! The adjustment indicator located in the back of the adjustment plate does not give the exact measurement to adjust. The indicator shows only the direction of adjustment and the category of magnitude.

FIGURE K

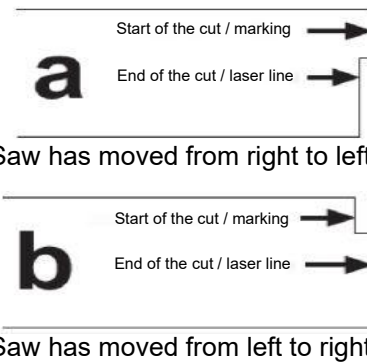

FIGURE L

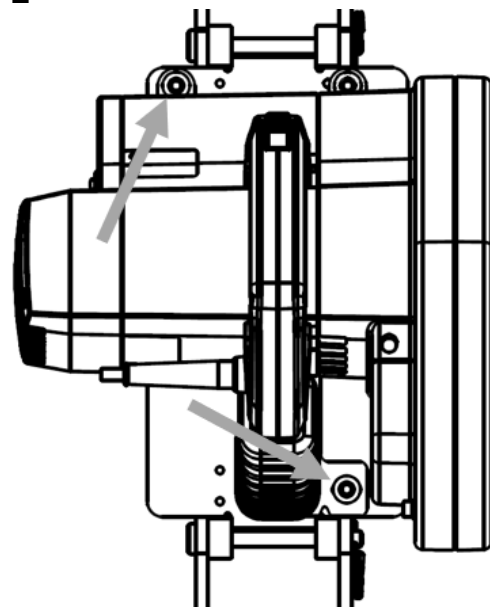
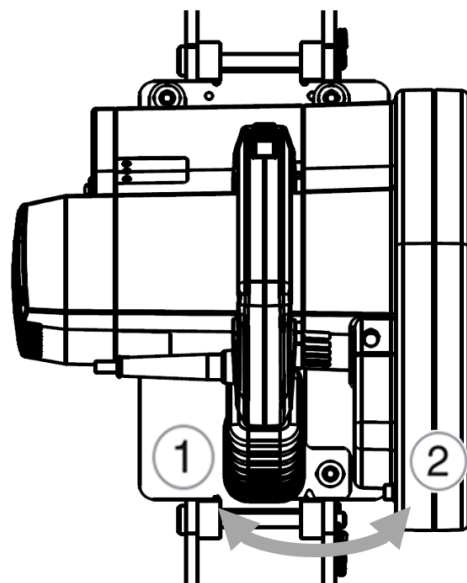

FIGURE N



Using the cutting depth adjustment (if equipped)

Cutting depth of the blade can be adjusted for maximum blade performance. To reduce blade body drag and maximize blade life, it is recommended to adjust the cutting depth so that the teeth of the blade are just visible inside the pipe.

Cutting depth adjustment is also needed to achieve the correct chamfer dimensions when using the Cut+Bevel diamond disc on cast iron pipes.

When adjusting the cutting depth, it is recommended to start the adjustment from a higher setting. Make the initial setting of cutting depth by turning the adjustment wheel.

For higher setting (smaller cutting depth) turn the adjustment wheel counter-clockwise (FIGURE O). For lower setting (deeper cutting depth) turn the adjustment wheel clockwise (FIGURE O).

After the initial setting of cutting depth, start piercing the pipe wall until the motor unit locks in cutting position (FIGURE E). Then it is easy to make the final adjustments by turning the adjustment wheel to required direction.

When finalizing the adjustment for the Cut+Bevel Diamond disc chamfer dimension, move the saw forwards to make the cutting result visible. Make the final adjustments based on the visible cutting result.

Once the adjustment is finalized and no further adjustments are made, the same setting is held, and it is valid for next pipes with the same dimensions.

FIGURE O

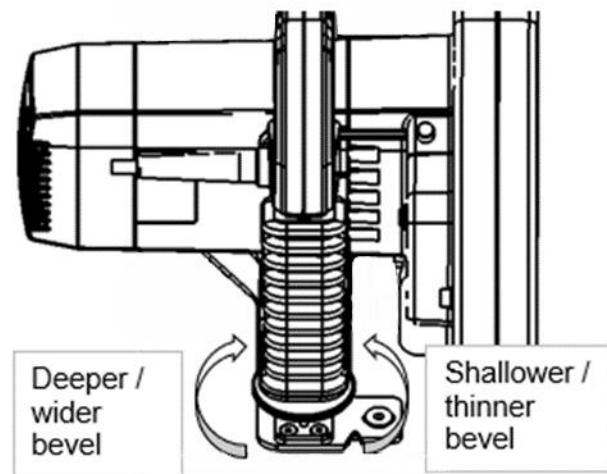

Installing and changing the saw blade

⚠ WARNING: To reduce the risk of injury, turn the unit off and disconnect it from the power source before installing and removing accessories, before adjusting or when making repairs. An accidental start-up can cause injury.

Remove the power plug from the socket.

Remove the blade guard cover (FIGURE P / 1) by opening the blade guard screw (FIGURE P / 2). Press the spindle-lock button (FIGURE A / 12) and simultaneously rotate the blade by hand until the spindle-lock button drops a further distance of about 7 mm. Now the rotation of the blade is prevented. Use the 5mm allen key to open the blade attachment screw.

Remove the securing screw and washer (FIGURE P / 3), the outer blade flange (FIGURE P / 4) and the blade (FIGURE P / 5).

Before installing a new blade, check that both blade flanges are clean. Place a new or sharpened blade on the back flange (FIGURE P / 6), so that the marked side of the blade is facing outwards and the arrows on the blade are facing in the same direction as the rotation direction markings on the inside of the blade cover. Ensure that the new blade goes right to the bottom on the back blade flange. Put the outer blade flange, and the securing bolt back in place. Press the spindle lock button and tighten the blade securing nut. Put the blade guard cover back in place and tighten the blade cover bolt.

FIGURE P

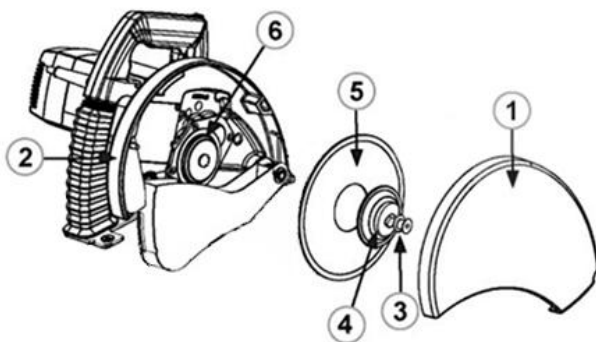

Maintenance and servicing instructions

Remove the power plug from the socket before servicing or cleaning the pipe saw. All maintenance operations carried out on the pipe saw's electrical components must be carried out by an approved service center or engineer.

Blade

Check the condition of the blade. Replace a bent, blunt, or otherwise damaged blade with a new one. Using a blunt blade can overload the pipe saw's electric motor and gearbox. When you notice that the blade is blunt do not continue cutting with it, as the blade may become so badly damaged that it will not be worth sharpening. A blade in sufficiently good condition can be sharpened a few times by a professional sharpening company. Diamond X Discs cannot be sharpened

Carrier units

Clean the carrier units regularly with compressed air. Lubricate the carriers quick release axles and tightening screws (FIGURE Q / 1 and 2). Clean and lubricate also the chain from time to time to ensure smooth operation of Pipe Cut Infinity.

Blade guard

⚠ WARNING: Regularly check the correct function of the lower blade guard. To check the function, first disconnect the tool from power source and then lift the lower blade guard to upper position by hand. After releasing the blade cover, it should return to lowest position without any delay or friction.

When you have cut plastic pipes and then intend to start cutting metal pipes always clean the inside of the blade guards. Hot metal particles originating from metal cutting will heat up plastic particles, which may release toxic smoke. Make it a rule to clean the blade guard regularly and pay special attention to keep the moving blade guard movement from becoming obstructed. Lubricate the axis of the moving blade guard regularly.

As an extra equipment you can buy outer blade guard with connection for vacuum cleaner. For extra equipment see page 18.

Motor

Keep motor air vents clean to allow free airflow.

FIGURE Q

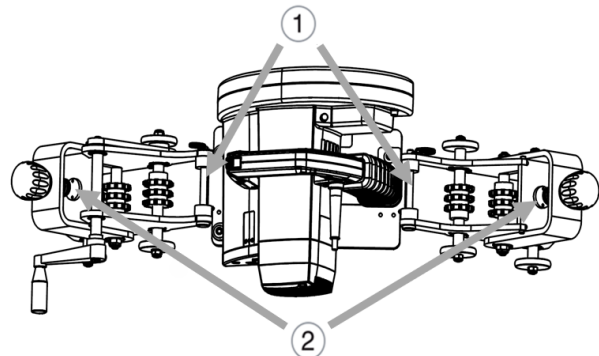

Plastic parts

Clean the plastic parts with a soft rag. Use only mild detergents. Do not use solvents or other strong detergents as they may damage the plastic parts and painted surfaces

Power cable

Check the condition of the power cable regularly. If the replacement of the supply cord is necessary, this has to be done by the manufacturer or his agent in order to avoid a safety hazard.

Correct use and regular servicing and cleaning will ensure the reliable operation of the pipe saw.

Environment

Separate collection. This product must not be disposed with normal household waste. When your Exact PipeCut machine is worn out, do not dispose it with normal household waste. This product must be recycled separately. Separate recycling of used products and packaging support recycling and recovery of materials. Reusing recycled materials helps preventing the pollution of the environment. According to local regulations it is possible to deliver household appliances to municipal rubbish depositories or to the dealer when purchasing a new product.

Guarantee

Warranty terms valid from 01.01.2018.

If the Exact PipeCut saw becomes unusable due to material or manufacturing defects within the Warranty Term, at our discretion we will repair the Exact PipeCut Saw or supply an entirely new or factory reconditioned Exact PipeCut Saw at no charge.

The Exact Tools Warranty Term is for 12 months from date of purchase.

The Warranty is only valid if:

- 1.) Copy of a dated purchase receipt is returned to the Authorized Warranty Repair Center or has been uploaded to our website at the time of warranty registration.
- 2.) The Exact PipeCut Saw has not been misused.
- 3.) No attempt has been made by non-approved persons to repair the saw.
- 4.) The Exact PipeCut Saw has been used in accordance with the operating, safety, and servicing instructions provide in these instructions.
- 5.) The Exact PipeCut Saw has been delivered to an Authorized Warranty Repair Center within the warranty period.

NOTICE! The Exact PipeCut Saw is to be shipped to the Authorized Warranty Repair Center freight prepaid. If the Exact PipeCut Saw is repaired under Warranty, the return shipment will be made freight prepaid.

CAUTION!

The following items or services are excluded for Warranty claims:

- Saw blades
- Carbon brushes
- Blade or attachment flange
- Blade attachment nut or screw
- Normal wear
- Failures caused by misuse or accident
- Water, fire or physical damage
- Cables
- Adjustment of eccentric adjustment wheel
- If a wrong type of generator has been used as power source.

Exact Pipe Cut operation tips

Diamond blades can only be used for cutting cast or ductile iron pipes. This pipe material is not recommended to cut using to a blade of any other type

Clean the inside of the blade guards after cutting plastic pipes.

Smaller pipes are easier to cut by turning the pipe manually either on the table or on the floor.

CAUTION! Turn the pipe towards yourself when you do it manually. Don't turn the pipe too fast.

Check the condition of the blade regularly.

The cutting process is divided into two stages: first you need to cut through the pipe wall and then cut around the pipe.

Do not overload the saw while working without interruption. The pipecut will overheat and metal parts can become very hot. In this case, the motor, the gearbox and the blade may become damaged.

Maintain a uniform feed rate. This increases the lifespan of the blade.

When not cutting, keep the motor unit in the up position. Never attach the tool on the pipe with motor unit in locked down / cutting position.

Factors influencing blade lifespan:

- Pipe material
- Blade suitability for the pipe material
- Correct motor speed setting
- Pipe wall thickness
- Feed rate
- Smoothness of the pipe
- General user knowledge
- Cleanliness of the pipe
- Corrosion on pipe
- Weld seam on the pipe
- Blade speed

Factors influencing straightness of cutting:

- Blade condition
- Pipe wall thickness
- Feed rate
- Smoothness of feed
- General user knowledge
- Cleanliness of the pipe
- Pipe circumference
- Too loose or tight gripping device
- Too tight blade

Extra equipment**Blade cover with vacuum cleaner connection.**

This blade cover is equipped with a connection for standard vacuum cleaners. Recommended to use when cutting plastic or materials that produce dust.

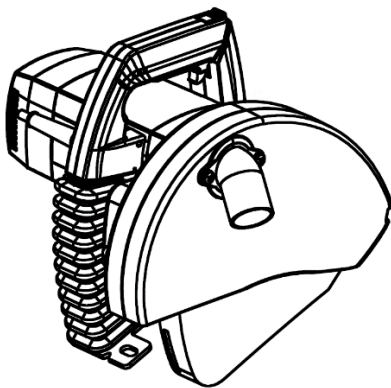
FIGURE R**Additional attaching chain segments**

When cutting of larger pipes is required, capacity beyond 1850mm can be achieved with additional chain segments. Chain segments are available in 2m pieces. These segments, together with the supplied segments, will allow attaching Exact Infinity to all pipe sizes.

Blade suitability

Exact TCT: Suitable for cutting steel and all kinds of plastic pipe material

Exact Cermet: Suitable for cutting stainless steel and acid proof materials, steel, copper, aluminum and all kind of plastic pipe materials.

Exact ALU: Suitable for cutting aluminum and all kinds of plastic.

Exact Diamond: Suitable only for cutting cast and ductile iron pipe materials, also for concrete lined cast iron pipes.

Exact TCT 140
Exact Cermet 140
Exact ALU 140
Exact Diamond X 140

Exact TCT 165
Exact Cermet 165
Exact ALU165
Exact Diamond X 165

Exact Cermet 180
Exact ALU 180
Exact Diamond X 180



Due to continuous product development, the manual may be updated.

No changes will be reported separately.

For more information check
www.exacttools.com

Extra equipment for PipeCut Infinity: Exact Cut+Bevel package for cast iron / ductile pipes

Cut+Bevel features

When using Diamond Cut + Bevel disc, the bevel depth and width is adjusted with depth adjustment dial (Figure T). Turning the dial clockwise will make deeper and wider bevel and turning it counterclockwise will make smaller and thinner bevel.

Please note that the adjustment dial only affects the position where the motor unit is locked down. It does not move the motor unit if it is not locked down.

When using the machine on a new pipe size, adjust the cutting depth higher than needed prior to cutting. It is easier to make the cut deeper by adjusting the depth adjustment dial during cutting. Correct depth setting is confirmed with visual evaluation of the cutting result.

The depth setting does not change if the depth adjustment dial is not moved. Therefore Cut + Bevel cuts can be made on same size pipes without any additional adjustment.

Beveling forces will push the saw to the right. To compensate these and achieve a straight cut, motor unit needs to be turned counterclockwise. The size of this adjustment depends on the pipe material, wall thickness, and bevel size. Therefore, it is not possible to provide a single optimal adjustment position.

To make the adjustment:

- Loosen the two screws on the body plate
- Turn body plate counterclockwise
- Tighten the screws

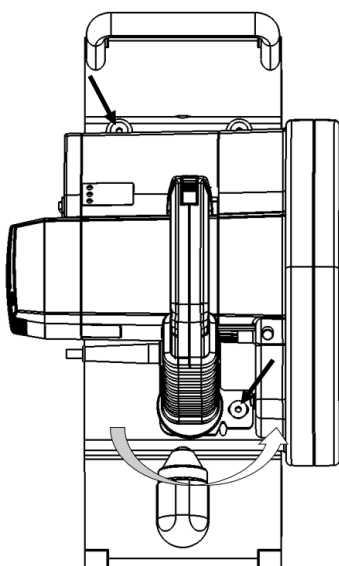

Changing the lower blade guard

When using the Cut+Bevel Diamond disc, be sure to use also the lower blade guard with wider opening on the bottom. Regular lower blade guard does not work with Cut+Bevel Diamond disc.

Lower blade guard is changed as follows (Figure S):

- Remove blade and blade flanges from the saw if fitted.

FIGURE S

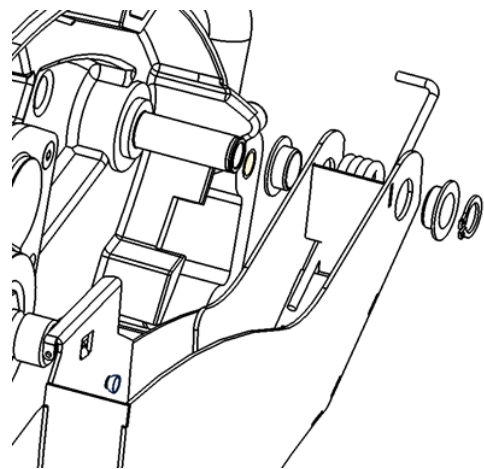

- Remove the retaining ring from the axle.
- Pull the lower blade guard, washer, spring and bushings of the axle. Note the locations of bushing and spring.
- Insert bushings into the lower blade guard to be installed
- Insert the lower blade guard with bushings, washer and spring on the axle. Be sure to locate the spring correctly.
- Test the correct function of the lower blade guard, it will return to low position when released and that it can move without any restriction.

FIGURE T

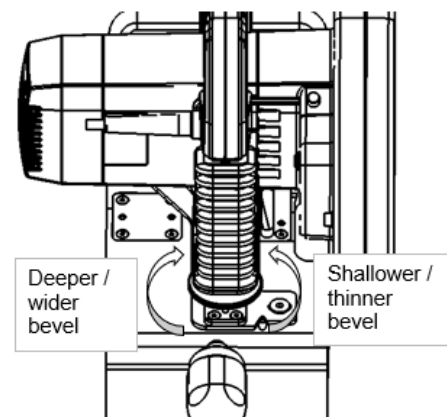

Maximum recommended pipe wall thicknesses of different materials, which can be cut by Exact Pipe Cut Infinity**Pipe Cut Infinity**

Steel pipes	Max.pipe wall thickness 20 mm (0,78") 230V / 0.5" (12mm) 120V
Stainless steel pipes	Max.pipe wall thickness 20 mm (0,78") 230V / 0.5" (12mm) 120V
Cast or ductile iron pipes	Max.pipe wall thickness 20 mm (0,78") 230V / 0.5" (12mm) 120V
Plastic, aluminum, copper	Max.pipe wall thickness 35 mm / 1.4"

ATTENTION! Do not cut pipes thicker than the above-mentioned wall thickness.

ATTENTION! Check the status and condition of the blade before cutting