

**exact**

**EN** Operating Instructions

# PipeCut HYDRA Infinity

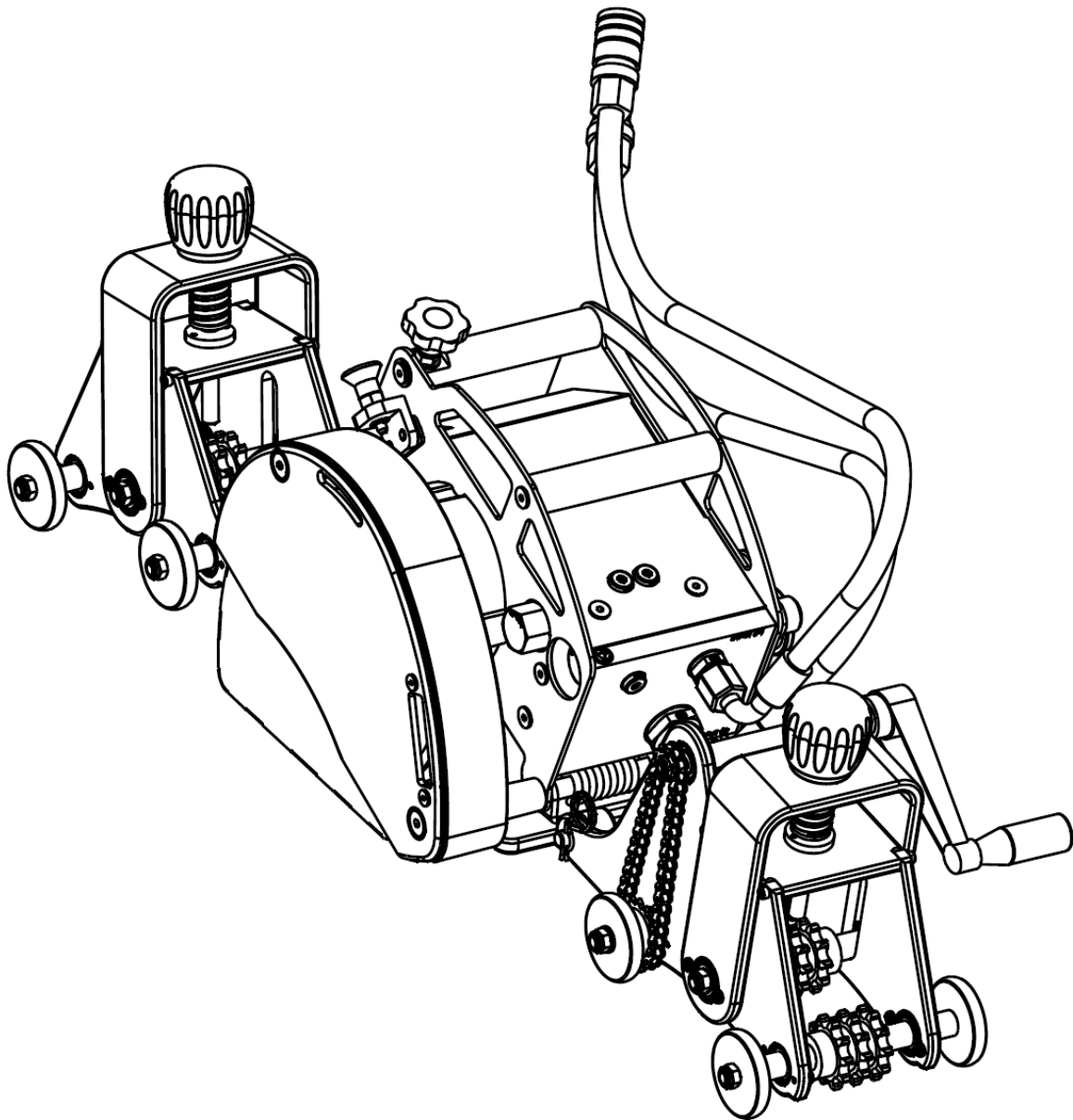

These are the original instructions.  
All instructions are available on website: [exacttools.com/manuals](http://exacttools.com/manuals)

**exact** Patents: US 7,257,895, JP 4010941, EP 1301311, FI 108927, KR 10-0634113

FIGURE A

- 1 Locking pin
- 2 Start button
- 3 Stop button
- 4 Blade guard cover
- 5 Cutting height adjustment
- 6 Moving blade-guard
- 7 Motor unit adjusting screws
- 8 Front tensioner with drive
- 9 Rear tensioner
- 10 Handles
- 11 Blade guard screws
- 12 Motor unit
- 13 Rating plate
- 14 Hydraulic hose - inlet
- 15 Hydraulic hose - outlet
- 16 Motor unit adjustment indicator
- 17 Tensioner tightening knobs
- 18 Quick release axles
- 19 Drive handle

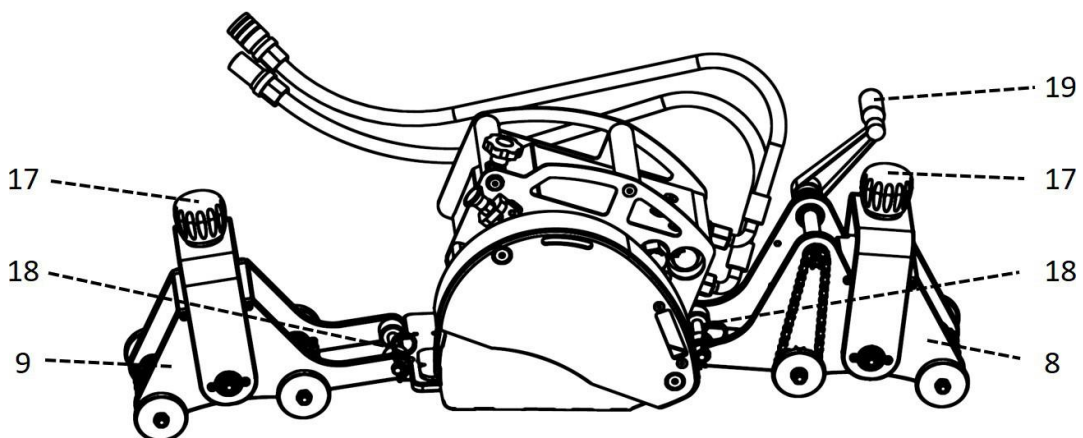
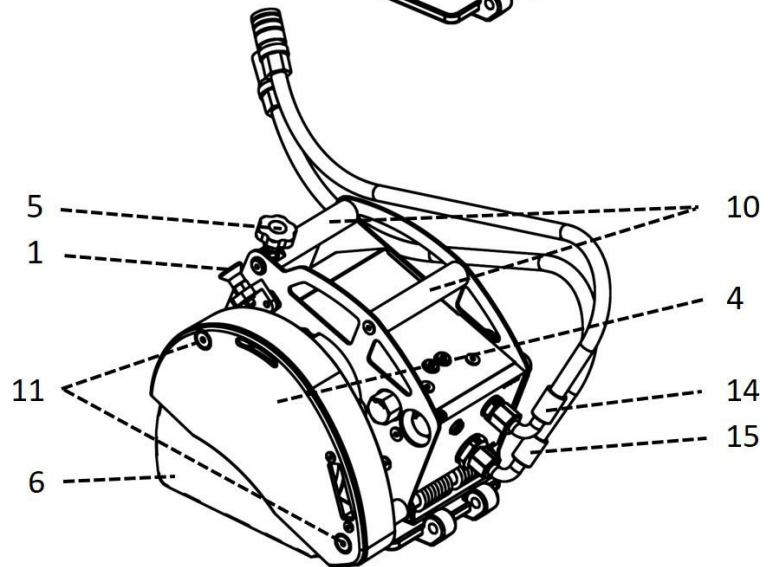
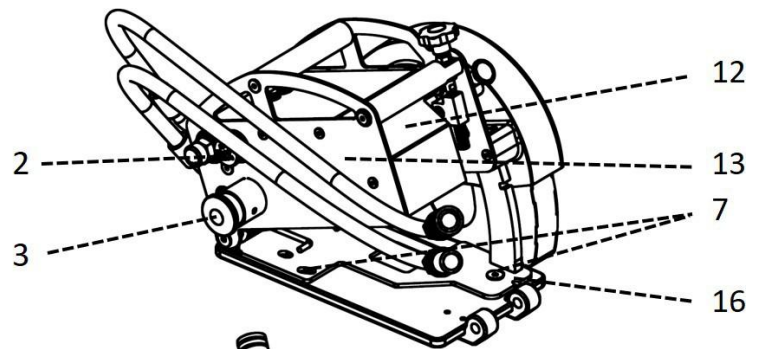

## Exact PipeCut HYDRA Infinity

### Data of Exact PipeCut saw blades

1. Exact TCT saw blades are for cutting steel, copper, aluminum and all kind of plastics pipe materials. Exact TCT saw blades can be sharpened.
2. Exact CERMET saw blades are for cutting stainless steel, acid proof materials, steel, copper, aluminum and all kind of plastic pipe materials. Exact CERMET saw blades can be sharpened.
3. Exact INOX saw blades are cutting for the hardest stainless steel and acid proof steel pipes. Exact INOX saw blades can be sharpened.
4. Exact CERMET ALU saw blades are for cutting all kind of aluminum and plastic pipe materials. Exact CERMET ALU saw blades can be sharpened.
5. Exact TCT P blades are for cutting all kind of plastic pipe materials. Exact TCT P saw blades can be sharpened.
6. Exact DIAMOND X discs are for cutting Cast or Ductile Iron only. Exact DIAMOND X discs cannot be sharpened.

---

## Declaration of Conformity

We declare under our sole responsibility that the pipe cutting machines Exact PipeCut Infinity Described under "Technical Data" are in conformity with the following standards or standardization documents:  
EN 62841-1:2015 according to the technical provisions of the directives 2006/42/EC and 2014/30/EU

For more information, please contact Exact Tools at the address below.  
The technical file is available at the address underneath  
The person authorized to compile the technical file:  
Marko Törrönen, R&D Manager, Exact Tools Oy (marko.torronen@exacttools.com)

Helsinki, 10.12.2024

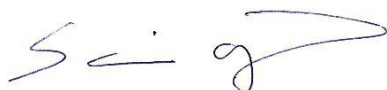

Sami Ojamo  
CEO  
Exact Tools Oy  
Martinkyläntie 41  
FI-01720 Vantaa  
Finland

**Contents****Information**

Technical data	5
Package contents	5

**Safety**

Safety instructions	6-12
---------------------	------

**Operation**

Functional description	12
Product features	12
Before operating the tool	13
Connection to mains power supply	13
Setting the pipe on supports	13
Attaching the pipe saw to the pipe	13
Piercing the pipe wall	14
Cutting around the pipe	14-15
Cutting result adjustment on Exact PipeCut Infinity Hydra	16
Using the cutting depth adjustment	17
Installing and changing the blade	18
Maintenance and servicing instructions	18
Environment / disposal	19
Guarantee / guarantee conditions	19-20
Tips for using Exact PipeCut saws	19-20
Extra equipment	21
Theoretical maximum cutting depths	22

## Exact PipeCut HYDRA Infinity saw

No-load speed	3400 1/min
Blade diameter	140 mm (5.6") - 190 mm (7.5")
Mounting bore	62 mm (2.44")
Weight	27kg (59 lbs) without chains
Range of use, pipe OD	360 mm– 1800 mm (14" – 71") with standard chain set
Max. pipe wall	25 mm (1") steel, 45 mm (1.8") plastics
Hydraulic pressure max.	150 bar (2200 PSI)
Hydraulic flow max.	25 l/min (6,6 GPM)
Oil quality requirement	Grade 32 – 64, depending on the operating temperature. Biogradable oil is recommended for environmental reasons.
Operating temperature	+40°C...-20°C / 104F...-4F
Operating conditions	Compatible with wet and underwater conditions

NOTE! If hydraulic pressure close to maximum is not attained, the machine can be used normally, but the machine's efficiency and working speed will decrease correspondingly.

### DELIVERY CONTENT

Package contents, please check that the package contains the following items:

1. Exact PipeCut HYDRA Infinity in shoulder bag
2. Operating instructions
3. 5 mm allen key
4. Open end wrench for blade change
5. Chain set for max. OD 1800 mm in a separate shoulder bag
6. Two hydraulic hoses + Exact Cermet 165 installed to the machine

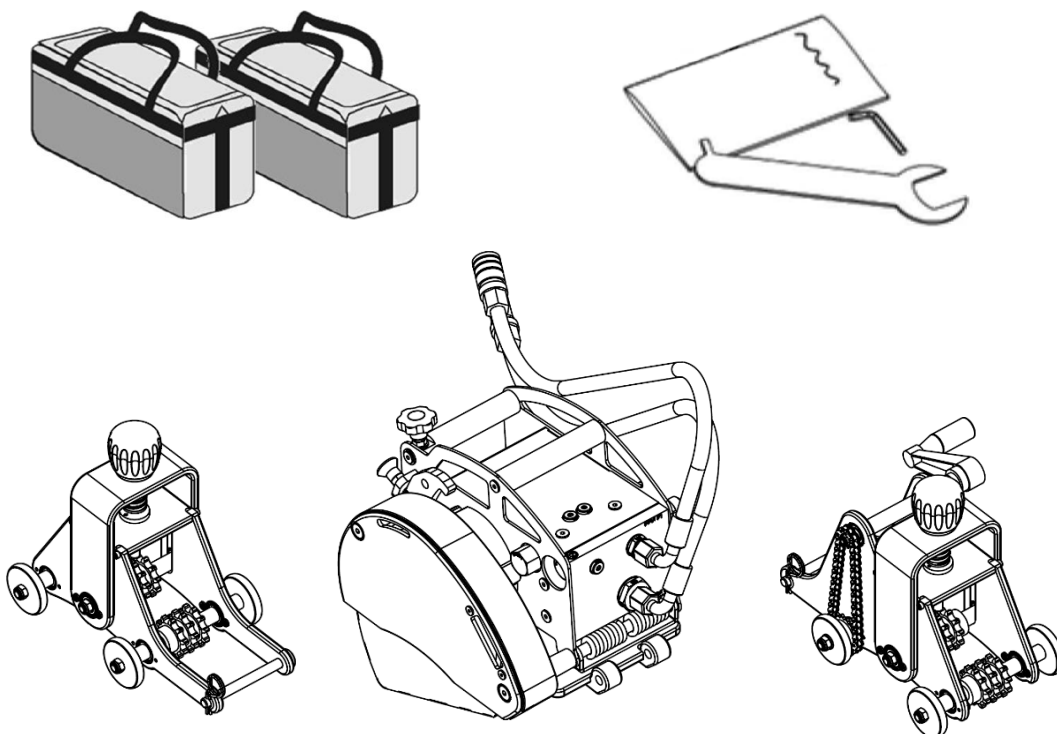

## Operating, safety, and servicing instructions

You now have the use of a completely new type of tool developed as a safe alternative to dangerous tools used to cut round pipes. The extremely effective Exact PipeCut HYDRA Infinity has been designed to cut various types of metals and plastics. It is absolutely essential that you carefully read and understand these operating, safety, and servicing instructions before using the pipe saw.

Keep this manual conveniently within reach of all pipe saw users. Make sure that all people using the saw have read and understood the dangers and operating instructions specified in this manual, and always follow the rules and regulations provided by occupational safety agencies.

The Exact PipeCut HYDRA Infinity pipe saw is for professional use only.

The definitions below describe the level of severity for each signal word. Please read the manual and pay attention to these symbols:



**DANGER:** Indicates an imminently hazardous situation which, if not avoided, will result in serious injury or in extreme cases a fatality



**WARNING:** Indicates a potentially hazardous situation which, if not avoided, could result in serious injury or in extreme cases a fatality



**CAUTION:** Indicates a potentially hazardous situation which, if not avoided, may result in minor or moderate injury.



**NOTICE:** Indicates a practice not related to personal injury which, if not avoided, may result in property damage.

### Symbols found on the machine.



Use ear protection.



Use gloves.



Read instructions before use.



**Saw blade:** Saw blade behind this cover, do not insert fingers or other body parts inside this cover.

## General safety regulations

**To reduce the risks of electric shock, fire, and injury to people, read all the instructions before using the tool.**

Our objective is to manufacture tools that enhance working safety and efficiency. The most important safety factor for this and any other tool is ITS USER. Your diligence and judgement are the best protection against accidents and injuries.

- Only qualified and trained operators should install, adjust or use the circular saw.
- Do not modify this circular saw. Modifications can reduce the effectiveness of safety measures and increase the risks to the operator.
- Do not discard the safety instructions; give them to the operator.
- Do not use the circular saw if it has been damaged.
- Tools shall be inspected periodically to verify that the rating plate displaying the nominal speed or operational pressure or stickers warning of dangers, are legible and have not become detached. The employer/user shall contact the manufacturer to obtain replacement marking labels where necessary.

### WARNINGS RELATED TO THE OIL FEED AND COUPLINGS

- Hydraulic oil under pressure can cause severe injury:
  - Always shut off oil supply, and disconnect tool from oil supply when not in use, before changing accessories or when making repairs
- Do not exceed the maximum oil pressure stated on the tool. The hydraulic oil pressure must not exceed 150 bar (2200 PSI [Pounds per square inch]) or the pressure specified on the tool's rating plate. Exceeding the pressure recommendation can result in the machine's breakage or a hazardous situation.
  - Never carry a hydraulic tool by the hose.
  - Do not inspect or clean the tool while the hydraulic power source is connected. Accidental engagement of the tool can cause serious injury. Watch out for the spinning blade and make sure that nothing has been caught in the saw's blade or other parts. Open the coupling only when you are sure that the hose is unpressurized.
  - Check the hose's condition before installation. A broken or worn-out hose may cause a hazardous situation.

### ENTANGLEMENT HAZARDS

- Stay clear of spinning grinding disks or blades.
- Entangled clothes, gloves, jewelry, ties, scarfs or long hair in the tool or its accessories can cause choking, scalp injuries, and/or deep wounds.

Never open the blade guard (Picture A / 5, page 1) if you are not sure if the blade or grinding disk has stopped spinning.

## PROJECTILE HAZARDS

- Failure of the workpiece, or accessories, or even of the inserted tool itself, can generate high-velocity projectiles.
- The machining of steel and other materials can quickly generate flying debris. Even small objects can injure the eyes and cause blindness.
- Always wear impact-resistant eye protection during the operation of the circular saw. The grade of protection required should be assessed for each use.
- Make sure that other users in the same area are also wearing protective goggles and safety masks.
- Make sure that the pipe to be cut is firmly supported. A weakly or improperly supported pipe may cause a hazardous situation.
- Make sure that the sparks generated by the machine can never, under any circumstances, come into contact with flammable and/or potentially explosive materials or liquids.
- Make sure that sparks or shavings pose no danger to other people at the job site.
- Ensure that the saw blade or cutter is properly clamped.

## ACCESSORY HAZARDS

- Before changing a blade, always shut off the oil feed, release the oil pressure from the hose and detach the tool from the oil feed source.
- Use only the recommended sizes and types of blades, do not use other types or sizes of accessories or consumables.
- Avoid direct contact with the inserted tool during and after use as it can be hot or sharp.
- Inspect the saw blade before use. Do not use saw blades which may have been dropped or which are chipped, cracked or otherwise defective.

## OPERATIONAL RISKS

- Users and servicers must be able to physically handle the tool's size, weight, and power.
- Hold the tool properly: be ready to react to any abnormal or sudden movement – keep both hands ready.
- Never use the tool unless the blade is aligned with the material to be cut.
- Avoid contact with the saw blade, knife or cutter to prevent the cutting of hands and other body parts.
- The PipeCut HYDRA Infinity is designed to be used with a blade guard that must always be in place to provide protection from shavings and other debris.
- Guards shall be securely in place and in good functional condition.
- Damaged, bent or severely worn guards shall be replaced with the tool manufacturer's recommended guards.
- Make sure that retractable guards return rapidly to their fully-closed position whenever released from the open position.
- Retractable guards shall never be clamped or tied in an open position or otherwise disabled.

- Use of the tool may expose the operator's hand to hazards including cuts and abrasion and heat. Wear suitable gloves to protect hands.
- Hold the tool correctly: be ready to counteract normal or sudden movements and have both hands available.
- Maintain a balanced body position and secure footing.
- Avoid injury by cutting or severing: avoid contact with saw blade, cutter or knife whenever the energy supply is connected to the tool. Wear protective equipment, such as gloves, apron and helmet.
- Injury can be caused by uncontrolled movements of the tool: always ensure that all the guide plate (if fitted) is held firmly against the workpiece.
- Cutting with these tools creates sharp edges; wear gloves to protect hands.
- Release the start-and-stop device in the case of an interruption of the energy supply.
- Use only hydraulic lubricants recommended by the manufacturer.
- Personal protective safety glasses shall be used; suitable gloves and protective clothing are recommended.
- Be aware that there is a running-on of the rotary inserted tool after the start-and-stop device has been released.
- Never move the machine unattached to the chain while the motor is running, or the blade is rotating.
- Do not use the tool if you are tired or your alertness has become impaired for health reasons.
- Do not start working if your foothold or balance is unsteady. Falling while holding a saw can cause a hazardous situation.

## REPETITIVE MOTIONS HAZARDS

- When operating the tool, the user may experience discomfort in hands, arms, shoulders, the neck, and other parts of the body.
- Work with a comfortable but secure stance and avoid an awkward or un-balanced working position. Varying your position during longer tasks can minimize discomfort and fatigue.
- Do not ignore symptoms such as continuous or periodic discomfort, pain, anxiety, ache, tingling, numbness, a burning sensation, or stiffness. Stop using the tool, inform your employer, and contact a doctor.

## NOISE HAZARDS

- Loud noises can cause permanent hearing defects and other problems such as tinnitus. Therefore, a risk assessment and implementation of appropriate controls for these hazards are essential.
- Appropriate controls to reduce the risk may include actions, such as damping materials to prevent workpieces from "ringing".
- Use hearing protection in accordance with the employer's instructions and as required by occupational health and safety regulations
- Operate and maintain the circular, oscillating or reciprocating saw as recommended in the instruction

handbook, to prevent an unnecessary increase in noise levels.

- Select, maintain and replace the consumable/inserted tool as recommended in the instruction handbook, to prevent an unnecessary increase in noise.

### VIBRATION HAZARDS

- Exposure to vibration can cause disabling damage to the nerves and blood supply of the hands and arms.
- Wear warm clothing when working in cold conditions and keep your hands warm and dry.
- If you experience numbness, tingling, pain or whitening of the skin in your fingers or hands, stop using the circular, oscillating or reciprocating saw, tell your employer and consult a physician.
- Operate and maintain the circular, oscillating or reciprocating saw as recommended in the instruction handbook to prevent an unnecessary increase in vibration levels.
- Select, maintain and replace the consumable/inserted tool as recommended in the instruction handbook, to prevent an unnecessary increase in vibration levels.
- Support the weight of the tool in a stand, tensioner or balancer, if possible.
- Hold the tool with a light, but safe, grip taking account of the required hand-reaction forces, because the risk from vibration is generally greater when the grip force is higher.
- Improper mounting of the saw blade can cause excessive vibration levels.

### WORKPLACE HAZARDS

- Keep the work area clean and well lit. Cluttered benches and dark areas increase the risks of electric shock, fire, and injury to people.
- Do not use the saw in areas or on terrain where there is the danger of falling or slipping. Make sure that your working position is as steady as possible and that you have a secure foothold.
- Always make sure that the ditch or shaft in which you are working is properly reinforced and that its edges are not in danger of collapsing. Make sure that the terrain is not in danger of giving way or settling.
- Proceed with care in unfamiliar surroundings. There can be hidden hazards, such as electricity or other utility lines.
- Ensure that there are no electrical cables, gas pipes, etc., which can cause a hazard if damaged by use of the tool.
- If the cutting operation is in a ditch or trench, access to the STOP button may be limited. Always have a co-worker ready to turn off the oil feed to the tool in the event of an emergency. A separate oil feed with a shutoff device can also be used for emergency situations.
- **Do not operate the tool in explosive atmospheres, such as in the presence of flammable liquids, gases, or dust.** The tool can create sparks resulting in the ignition of the dust or fumes.
- The circular, oscillating or reciprocating saw is not intended for use in potentially explosive atmospheres and is not insulated against coming into contact with electric power.
- Slips, trips and falls are major causes of workplace injury. Be aware of slippery surfaces caused by use of the tool and also of trip hazards caused by the hydraulic hoses.
- Keep bystanders, children, and visitors away while operating the tool. Distractions can result in the loss of control of the tool.

### DUST AND FUME HAZARDS

- Dusts and fumes generated when using circular, oscillating and reciprocating saws can cause ill health (for example cancer, birth defects, asthma and/or dermatitis); risk assessment and implementation of appropriate controls for these hazards are essential.
- Risk assessment should include dust created by the use of the tool and the potential for disturbing existing dust.
- Operate and maintain the circular, oscillating or reciprocating saw as recommended in the instruction handbook, in order to minimize dust or fume emissions.
- Direct the exhaust so as to minimize disturbance of dust in a dust-filled environment.
- Where dusts or fumes are created, the priority shall be to control them at the point of emission.
- All integral features or accessories for the collection, extraction or suppression of airborne dust

or fumes should be correctly used and maintained in accordance with the manufacturer's instructions.

- Select, maintain and replace the consumable/inserted tool as recommended in the instruction handbook to prevent an unnecessary increase in dust or fumes.
- Warnings shall be given against the risk of explosion or fire due to the material being processed.
- Use respiratory protection in accordance with the employer's instructions and as required by occupational health and safety regulations.
- Working in certain materials creates emission of dust and fumes, causing potentially explosive environments.
- Avoid the inhalation of dust and vapors, as well as the handling of job site waste that could cause health hazards such as, for example, cancer, birth defects, asthma, and/or dermatitis. Use dust extraction equipment and a breathing mask when the material to be cut releases airborne particles.
- Some sawing generates dust containing chemicals that, according to the state of California, can cause cancer, birth defects, and other reproductive harm.

Examples of these kinds of chemicals include:

- lead from lead-based paints,
- crystalline silica from bricks, cement, and other masonry products,
- arsenic and chromium from chemically-treated rubber.

Your risk from these exposures will vary depending on how often you do this type of work.

To reduce your exposure to these chemicals, work in a well ventilated area and use approved protective equipment such as dust masks specifically designed to filter out microscopic particles. Working without the appropriate protective equipment is prohibited.



**DANGER: Explosives and flammable materials, liquids and gases:**

#### **Danger of explosion**

If used in explosive atmospheres, the tool may cause an explosion and/or fire.

Explosions are dangerous and may cause extremely serious accidents, injuries, or death. Because the tool often creates sparks while sawing, it must never be used near any kind of potentially explosive or highly flammable material, liquid, or gas. Thoroughly familiarize yourself with the national, state-specific, and local safety instructions related to working near or among, explosive materials.

- Never use the tool near explosives or highly flammable materials, liquids, or gases.
- Never work in highly flammable or explosive atmospheres.
- Make sure that your work area has no hidden gas sources or explosives.

- If there are explosives, highly flammable materials, liquids, or gases at your job site, make sure that they do not pose a danger and cannot come into contact with sparks created by the saw.

#### **HYDRAULIC OIL FEED**

- a) **Never connect to an oil feed that is capable of exceeding 150 bar / 2200 psi** [Pounds per square inch]. Over pressurizing the tool can result in bursting, abnormal operation, breakage of the tool or serious injury to persons. Use only clean oil meeting the requirements at the rated pressure or within the rated pressure range as marked on the tool. Always verify prior to using the tool that the oil source has been adjusted to the rated oil pressure or within the rated oil pressure and flow (max. 25 l/min [6,6 GPM]) range.
- b) Overspeed caused by excessive oil pressure and flow should be avoided with the pressure / flow regulators. Recommended pressures and oil flow must not be exceeded when using the machine. Excessive pressure or oil flow may cause the breakage of the machine, blade, and accessories, or a hazardous situation resulting in serious personal injury or damage to the equipment.
- c) Couplings and oil hoses must be in good condition. Check the couplings, oil hoses, and hydraulic power source before use. Never work with a damaged coupling, oil hose or hydraulic power source.

## Safety information

 **DANGER:** Failure to comply with these operating instructions may result in serious injury or death.

- Make sure that the pipe being cut is correctly supported, and that each end of the pipe on both sides of the sawing point cannot collapse uncontrollably as the pipe is being cut.
- Make sure that sparks do not endanger people or materials. Sparks may cause accidents if they come into contact with flammable materials, liquids, or gases. See the section Explosives and Flammable Materials, Liquids and Gases, page 7.
- Personal protection equipment must be used as described in the chapter Personal Protective Equipment, page 8.
- Slipping, stumbling, or falling must be indicated as the reason for a serious accident or fatality. Watch out for excessively long hoses left at the job site.
- Work carefully in unfamiliar locations. For example, hidden electrical cables may cause a danger.
- Maintain a balanced position and a steady foothold.
- If an improperly installed or damaged tool vibrates excessively, react quickly. Shut off the device or cut off the oil pressure if possible.
- Stay clear of spinning blades. Do not detach the pipe saw from the pipe before the spinning motion has stopped.
- If there is a fault in the hydraulic energy feed, press the STOP button (Picture A / 3, page 1).

## Personal safety precautions and requirements

Only trained persons familiar with all general safety regulations, as well as the possible dangers occurring at job sites, may use this tool.

Users are capable if they:

- are able to handle the size, weight, and power of the device.
- are trained to use this device according to national, state-specific, and local instructions.
- are familiar with, and understand, all national, state-specific, and local safety regulations, as well as precautionary measures aimed at accident prevention.
- have read and understood this manual.
- have not ingested alcohol, drugs, or medications impairing alertness or the ability to work.

## Personal safety

- WEAR APPROVED HEARING AND EYE PROTECTION
- WEAR APPROVED HAND PROTECTION

 **WARNING: READ AND UNDERSTAND THE INSTRUCTION MANUAL PRIOR TO USE**

- a) **Stay alert. Watch what you are doing and use common sense when operating the tool. Do not use the tool while tired or under the influence of drugs, alcohol, or medication.** A moment of inattention while operating the tool increases the risk of injury to persons.
- b) **Dress properly. Do not wear loose clothing or jewelry. Contain long hair. Keep hair, clothing, and gloves away from moving parts.** Loose clothes, jewelry, or long hair increases the risk of injury to persons as a result of being caught in moving parts.
- c) **Avoid unintentional starting. Be sure the switch is off before connecting to the hydraulic oil supply.** Do not carry the tool with your finger on the switch or connect the tool to the oil supply with the switch on.
- d) **Do not overreach. Keep proper footing and balance at all times.** Proper footing and balance enable better control of the tool in unexpected situations.
- e) **Use safety equipment.** A dust mask, non-skid safety shoes and a hard hat must be used for the applicable conditions.
- f) **Always wear eye protection.**
- g) **Always wear hearing protection when using the tool.** Prolonged exposure to high intensity noise is able to cause hearing loss.

h)  **WARNING: Risk of electric shock. This tool is not provided with an insulated gripping surface. Contact with a live wire will also make exposed metal parts of the tool live and a risk of electric shock to the operator.**

- i) **Avoid body contact with grounded surfaces such as pipes, radiators, ranges and refrigerators.** There is an increased risk of electric shock if your body is grounded.
- j) **Explore the workpiece to avoid contact with hidden wiring.** Thoroughly investigate the workpiece for possible hidden wiring before performing work. Contact with live wiring will shock the operator.

## Personal protective equipment

 **DANGER: Danger of being caught in moving parts:**

- Do not wear loose jewelry, clothing, or uniforms. Make sure that possible shirtsleeves, shoelaces, and/or pants cannot be caught by the machine's moving parts or become entangled with any other object or natural feature at the job site.
- To minimize the danger of choking, make sure that any collar, tie, or hood cannot become entangled with the device, cords, or accessories.

- To minimize the danger of entanglement, make sure that hair and headgear cannot be caught by the device's moving parts, cords, or accessories.

Personal protective equipment must conform to the applicable health and safety requirements. Always use the following personal protective equipment:

- Hard hat conforming to occupational safety requirements.
- Sufficient hearing protection.
- Safety goggles or visor for eye protection.
- Cut-resistant safety gloves.
- Non-skid safety shoes conforming to occupational safety regulations.
- Breathing mask.



**WARNING: Intoxicants:**

Drugs, alcohol, and medications may weaken attention, judgement, and/or the ability to concentrate. Impaired reflexes, unsteady balance, hallucinations, and miscalculations may cause serious workplace accidents such as personal injuries, damage to tools and property, or death.

Never use the tool if you are under the influence of alcohol, intoxicating medications, and/or drugs.

If you know about, or notice someone using alcohol, drugs, or intoxicating medications, make sure that he or she is not using the tool.



**DANGER: Electric shock**

If the device comes into contact with electric circuits or other power sources, it may cause serious injury or death. Always make sure there are no cables, wires, or circuits running inside or near the pipe to be cut that could conduct electricity to the device or user.

- Do not work near electrical circuits or other sources of electric currents.
- Make sure that your working area has no hidden electrical circuits and that the pipe to be sawn is not in contact with any kind of electrical circuit, power source, cable, wire, or transformer.
- Make sure that any water coming from inside the pipe or existing at the job site does not cause the danger of electric shock, and that no water comes into contact with any kind of electrical circuit, power source, cable, wire, or transformer.



**WARNING:** High pressure hydraulic oil can cause serious injuries

- Always close the oil feed, release the pressure from the piping, and detach the tool from the oil feed when it is not being used, repaired, or adjusted, for example when blades are being replaced.
- Never change blades or service the tool while it is still connected to the oil feed. Always make sure the device is detached from the high pressure oil source when performing an inspection or servicing operation. Make sure that the motor is

completely shut off and that the hoses are not pressurized.



**WARNING: Vibration**

Avoid exposure to vibration; it can damage the nervous system as well as hinder blood circulation in hands and arms. This may in turn cause pain in sensitive joints and possible old injuries.

- Always use sharp blades whose condition has been checked. A faulty or damaged blade must never be used for sawing and should be replaced with an intact blade. Dull, damaged, or faulty blades may intensify vibration.
- Avoid exposure to vibration. Long-term exposure to vibration may cause injuries to the user's joints and/or nervous system.



**CAUTION Only professional technicians may use and test the PipeCut HYDRA Infinity pipe saw.**

The pipe saw may not be tested or serviced by persons untrained in the servicing of hydraulic tools. Servicing personnel must be authorized to test these kinds of tools and use a hydraulic system according to national, state specific, and local regulations.

## PipeCut lower guard

Check lower guard for proper closing before each use. Do not operate saw if lower guard does not move freely and close instantly.

Never clamp or tie the lower guard into the open position. If saw is accidentally dropped, lower guard might be bent. Raise the lower guard and make sure it moves freely and does not touch the blade or any other part, in all depths of cut.

Check the operation and condition of the lower guard spring. If the guard and the spring are not operating properly, they must be serviced before use. Lower guard might operate sluggishly due to damaged parts, gummy deposits, or a buildup of debris. For all sawing, the lower guard should operate automatically.

Always observe that the lower guard is covering the blade before placing saw down on bench or floor. An unprotected, coasting blade will cause the saw to walk backwards, cutting whatever is in its path. Be aware of the time it takes for the blade to stop after switch is released.

Always use blades with correct size and shape (diamond vs. round) arbor holes. Blades that do not match the mounting hardware of the saw will run unpredictably, causing loss of control.

Never use damaged or incorrect blade washers or bolts. The blade washers and bolt were specially designed for your saw, for optimum performance and safety of operation.

When blade is binding, or when interrupting a cut for any reason, cut the oil feed and hold the saw motionless in the material until the blade comes to a

complete stop. Never attempt to remove the saw from the work or pull the saw backward while the blade is in motion or KICKBACK may occur. Investigate and take corrective actions to eliminate the cause of blade binding.

Use the lower blade guard with wider opening, whenever using Diamond Cut Bevel disc.

## Tool use and maintenance

To keep the PipeCut HYDRA Infinity pipe saw safe follow the following maintenance and check procedures.

- a) **Use clamps or another practical way to secure and support the workpiece to a stable platform.** Holding the work by hand or against the body is unstable and is able to lead to loss of control.
- b) **Do not force the tool.** Use the correct tool for the application. The correct tool will do the job better and safer at the rate for which the tool is designed.
- c) **Do not use the tool if the switches do not turn the tool on or off.** Any tool that cannot be controlled with the switches is dangerous and must be repaired.
- d) **Disconnect the tool from the oil source before making any adjustments, changing accessories, or storing the tool.** Such preventive safety measures reduce the risk of starting the tool unintentionally.
- e) **Store the tool when it is idle out of reach of children and other untrained persons.** A tool is dangerous in the hands of untrained users.
- f) **Maintain the tool with care.** Keep a cutting tool sharp and clean. A properly maintained tool, with sharp cutting edges reduces the risk of binding and is easier to control.
- i) **When not in use, cap the hydraulic oil inlet and outlet couplings to prevent debris to enter the tool.** Debris can cause malfunction and increased wear of the tool.
- g) **Before each use, check for misalignment or binding of moving parts, breakage of parts, and any other condition that affects the tool's operation.** If damaged, have the tool serviced before use. Many accidents are caused by poorly maintained tools. There is a risk of bursting if the tool is damaged.
- d) **Always clean the blade guard's inside surfaces (Picture C / C1, page 17), if you have sawed plastic and are now sawing metal pipes.** The warming of the metal shavings and blade from the sawing may cause the plastic to melt or smolder, possibly releasing toxic gases. Clean the blade guard after each use and pay particular attention to the functioning of the lower blade guard (Picture C / C7, page 17). The lower blade guard should move freely, and make sure that there is no debris,

shavings, or sand in its mechanism's moving parts that could impair its functioning.

- e) **Clean the gripper unit regularly, at least after each working day with clean compressed air.**

Lubricate the gripper's trapeze screw, transfer nuts, wheels, hinges (Picture A / A14, page 12), and ball bearings with the applicable oil. Check that there is no debris, chips, or other materials that could hinder its functioning in the gripper.

- f) **Clean the blade guard's inside after each working day.** Tool blade guards can become cluttered causing bad performance, increased wear of cutting tool and overheating if debris is not cleaned out.

- e) **Check the free running speed of PipeCut 360 HYDRA regularly, at least annually.** Measurement can be taken from blade axle with appropriate RPM counter. For safety reasons, do not have the blade attached while measuring. Free running speed should not exceed the rating plate information.

## Intended Use

### PipeCut Infinity

PipeCut HYDRA Infinity pipe saw is intended for use as a pipe fitter's tool at the job site.

PipeCut HYDRA Infinity can only be used to cut round pipes, with a diameter of 360mm – 1850mm (14"– 71")

PipeCut HYDRA Infinity can be used to cut pipes with greater diameter if additional chain sections are used. Chain delivered with the PipeCut Infinity works on pipes with diameter up to 1850mm.

Maximum wall thicknesses:

Steel	25 mm (1.0")
Plastic	45 mm (1.8")

PipeCut Infinity pipe saw can be used to cut all normal pipe materials, such as steel, stainless steel, cast/ductile iron, copper, aluminum and plastic. When cutting different materials, always use appropriate blade.

See the cutting depth table on page 22.

PipeCut HYDRA Infinity pipe saw is not intended for use in industrial production.

Use only blades within the diameter range stated in technical data.

Do not use any blade with lower speed marking than no-load speed marked on the power tool.

Use pipe holders to support the pipe being cut.

With additional accessories PipeCut Infinity can also be used for simultaneous cutting and beveling of cast or ductile iron pipes. See page 21 for more information.

## Exact PipeCut Infinity pipe cutting system operation

### Before operating the tool

- Ensure that motor unit is in the upright position.
- Check that the blade is correctly fitted, in good condition and suitable for the material to be cut.
- Check the operation of the lower blade guard.
- Ensure the pipe is empty.

### Setting the pipe on supports

As the saw needs to go around the pipe, the pipe needs to be supported above ground. Minimum recommended clearance to obstacles is 300mm for the crank to be accessible (Fig B).

Make sure that the pipe is supported well and it is remains stationary even after the cut.

**⚠ WARNING:** Be sure to support the pipe on at least two places on both sides of the cut. Failure to support the pipe halves correctly can lead to personal injury and/or damage to equipment.

If you only cut a short section of the pipe, for example to straighten the end, take care of the cut section falling off when the cut is completed. In these cases, always start the cut from the top of the pipe to avoid injury.

### Attaching the pipe saw to the pipe

Assemble the Infinity. (Fig C)

- Attach the carrier with the crank in front of the motor unit. Use the supplied quick release axle for the connection and lock it in place with the locking pin.
- Attach the carrier without the crank behind the motor unit. Use the supplied axle and lock it in place with the pin.

Select correct chain pieces according to the supplied table and join them together.

- Adjust the tension sprockets to their lowest position.
- Route the chain through carrier as in the picture (FIGURE C1), over the center sprocket and under wheel axles. Do this for both carriers.
- Position the saw on top of the pipe and connect the chain ends together.
- Align the chain to follow the cutting line. Cutting line is 90mm from the side of the chain.
- Tighten the chain with the help of both tensioners. Turn the tightening knobs clockwise (FIGURE C2).
- When the chain is tight, circle the saw around the pipe at least once by turning the crank. This will straighten the chain.
- Re-tighten the chain if it came loose.
- Repeat the two previous steps if needed.

### Connection to the hydraulic power supply

Ensure that the hydraulic pressure source meets the requirements and limits mentioned on the technical data table on page 3.

Connect the hydraulic hoses unpressurized to the correct connecting point (flow IN / OUT).

FIGURE B

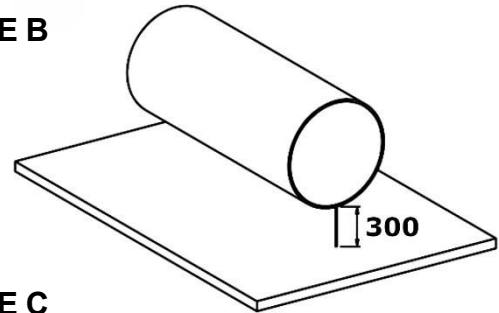

FIGURE C

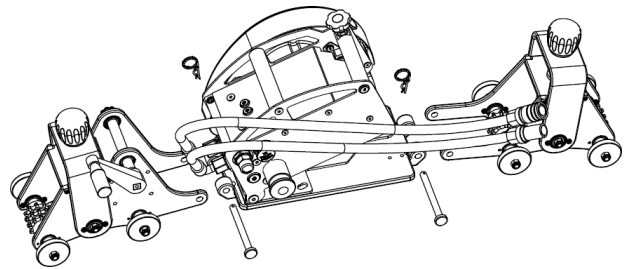

FIGURE C1

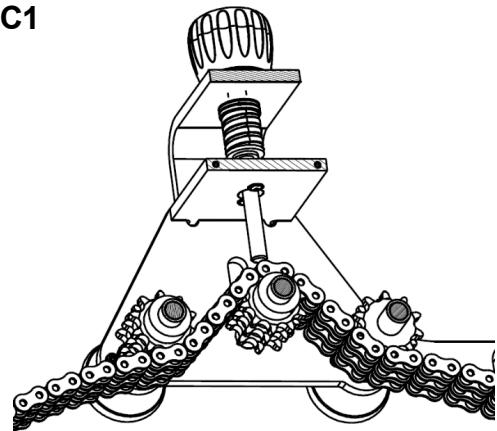
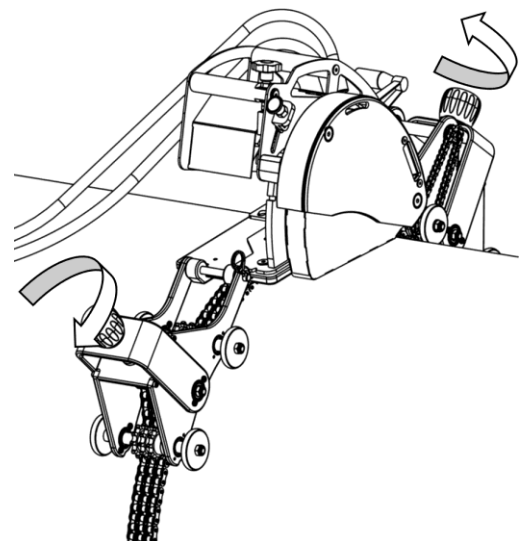

FIGURE C2



**BEFORE USING THE PIPE SAW, CHECK THAT:**

- the sliding lower blade guard slides freely.
- the motor unit's locking mechanism functions perfectly.
- tensioner units' wheels turn freely.
- the hydraulic oil in- and outlet connections are undamaged, and the hoses are securely tightened.
- the pipe to be cut is firmly supported on both sides of the cutting point.
- you have the right type of blade, specifically designed to cut the material to be sawed, installed in the machine.
- the blade is in good condition and is tight.
- you have the proper personal protection equipment as specified in the operational safety section of this manual.
- there is enough oil in the hydraulic oil tank of a power pack or other hydraulic oil pressure source in use.

**Starting the motor**

Make sure that STOP button has been pulled to its out-position (Picture D / 1). If the STOP button is at its in-position, the motor will not start.

Start the motor by pushing the START button (Picture D / 2).

**Piercing and sawing the pipe wall**

Make sure that all people working near the pipe saw have the appropriate personal protection equipment.

When the motor has reached the full no load speed: pierce the pipe's wall by gently pushing the pipe saw's operating handle directly downwards with an even pressure until the blade has cut through the pipe's wall and the motor unit has locked in the sawing position. You can see when the locking pin (Picture E / 1) snaps into the slot designed for it (Picture E / 2) and drops down slightly.

The motor unit is locked in the sawing position, and you can safely begin to cut the pipe.

**Cutting around the pipe**

Start cutting by turning the crank forwards (FIGURE F / 2).

Do this at a steady speed and pay attention to blade speed. If the speed starts to decrease, slow down with the feeding.

In case the motor stops during cutting, release motor locking and raise it to the up position so that the blade is not in contact with the pipe. Push start button to restart the motor (FIGURE D / 2). Gently push the motor down to cutting position (FIGURE F/2) and continue cutting once motor is locked in.

Do not leave the saw standing steady and motor running with the blade in contact with the pipe. This will heat up the blade and cause loss of cutting performance and blade life.

**FIGURE D**

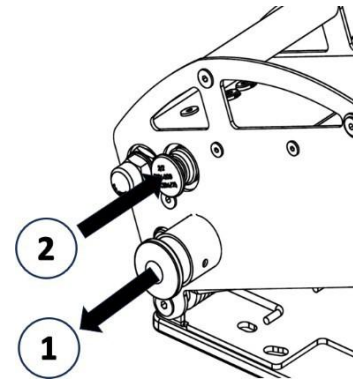

**FIGURE E**

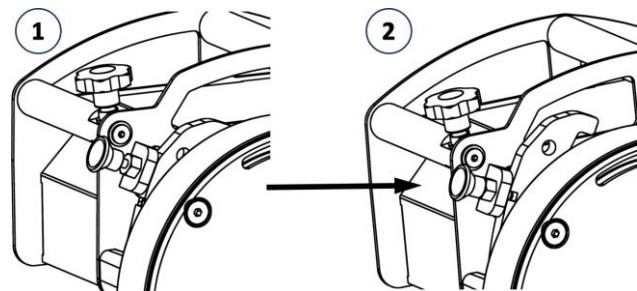

**FIGURE F**

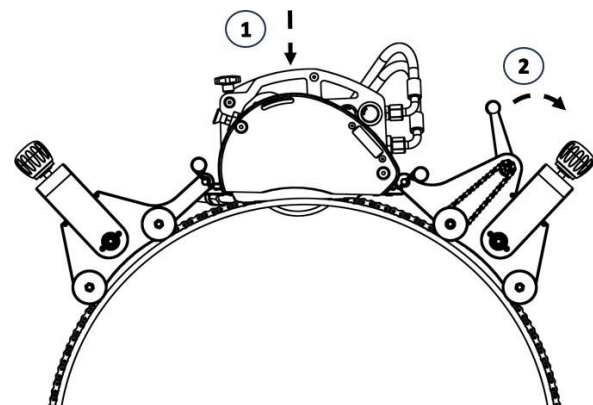

When the pipe is cut off, pull the locking pin until the locking is released (FIGURE H 1 / 2).

Raise the motor unit to starting position (FIGURE I / 1). Push the red STOP button (FIGURE I / 2) to turn off the motor. After the saw blade has stopped, ensure that the moving lower blade-guard is lowered into down position.

Loosen the chain by turning the tightening knobs counterclockwise.

Cut the chain into separate pieces by removing the attachment pins.

Should there be problems during piercing or cutting; abnormal sounds or vibrations or you must interrupt cutting before the pipe is cut, release the motor unit locking by pulling the locking pin until the locking is released and lift the motor unit up. Once the problem is cleared, start cutting again.

Never start the motor when it is locked in sawing position, or the teeth of the blade are in contact with the pipe to be sawn.

FIGURE H

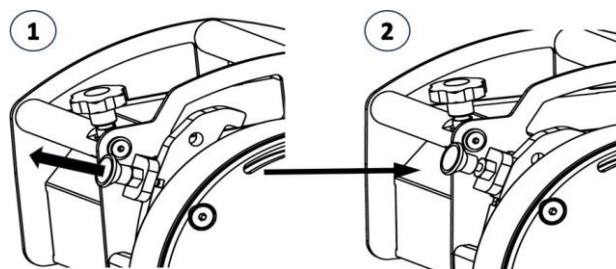
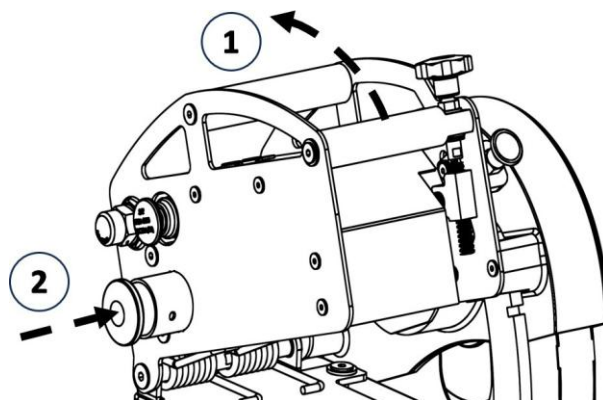

FIGURE I



### Cutting result adjustment on Exact PipeCut HYDRA Infinity

The cut is affected by many factors, for example the size of the pipe, material, wall thickness, quality of the pipe's surface, roundness, welded seams, blade condition, feed rate, operator's experience. For these reasons, the saw may move to left or right causing unperfect cut (see FIGURE K).

Infinity is heavily guided by the chain attaching the saw to the pipe. It is important to place the chain correctly and parallel to the pipe centerline. Rotating the saw around the pipe before cutting helps to align the chain.

If the cutting result is still not square, blade alignment can be adjusted.

#### Adjusting the alignment of the blade

**CAUTION!** Blade alignment adjustment is very effective and can lead to blade and/or saw damage if adjusted too much.

Before making the adjustment, note the bodyplate alignment in case it is needed to return back to the original setting.

Loosen the two screws securing the bodyplate (FIGURE L). Turn the bodyplate to the required direction and tighten the two screws. Make only small adjustments at a time.

If the cutting line goes from right to left (FIGURE K/a), turn the bodyplate clockwise (FIGURE N / 1).  
If the cutting line goes from left to right (FIGURE K/b), turn the bodyplate counterclockwise (FIGURE N / 2).

**CAUTION!** The adjustment indicator located in the back of the adjustment plate does not give the exact measurement to adjust. The indicator shows only the direction of adjustment and the category of magnitude.

FIGURE K

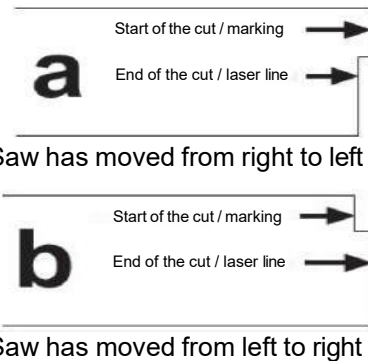

FIGURE L

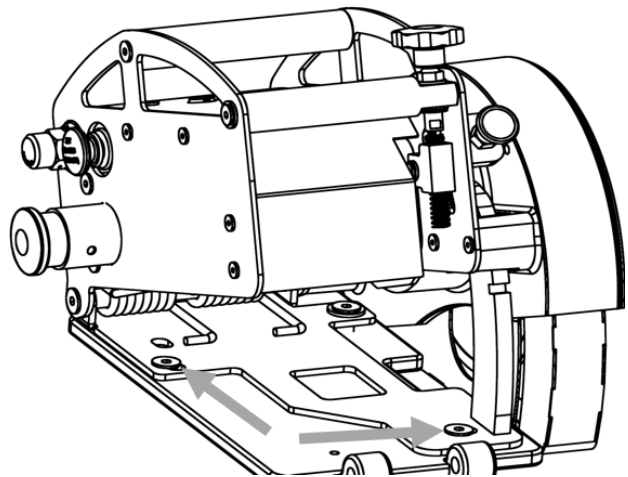
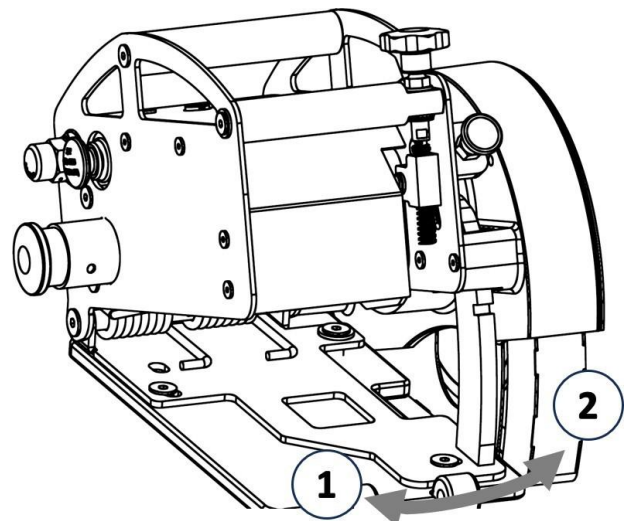

FIGURE N



## Using the cutting depth adjustment

Cutting depth of the blade can be adjusted for maximum blade performance. To reduce blade body drag and maximize blade life, it is recommended to adjust the cutting depth so that the teeth of the blade are just visible inside the pipe.

Cutting depth adjustment is also needed to achieve the correct chamfer dimensions when using the **Cut+Bevel diamond disc (accessory package)** on cast iron pipes.

When adjusting the cutting depth, it is recommended to start the adjustment from a higher setting. Make the initial setting of cutting depth by turning the adjustment wheel.

For higher setting (smaller cutting depth) turn the adjustment wheel counter-clockwise (FIGURE O). For lower setting (deeper cutting depth) turn the adjustment wheel clockwise (FIGURE O).

After the initial setting of cutting depth, start piercing the pipe wall until the motor unit locks in cutting position (FIGURE E). Then it is easy to make the final adjustments by turning the adjustment wheel to required direction.

When finalizing the adjustment for the Cut+Bevel Diamond disc chamfer dimension, move the saw forwards to make the cutting result visible. Make the final adjustments based on the visible cutting result.

Once the adjustment is finalized and no further adjustments are made, the same setting is held, and it is valid for next pipes with the same dimensions.

FIGURE O

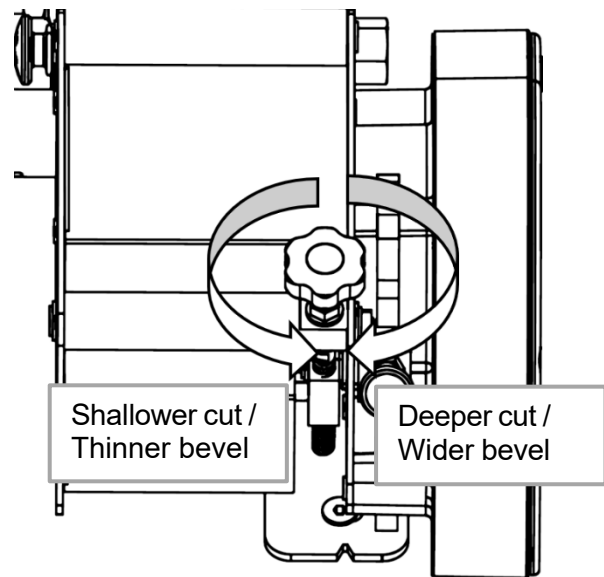

### Installing and changing the saw blade

**⚠ WARNING:** To reduce the risk of injury, turn the unit off and disconnect it from the power source before installing and removing accessories, before adjusting or when making repairs. An accidental start-up can cause injury.

Remove the blade guard cover (FIGURE P / 1) by opening the blade guard screws (FIGURE P / 2).

Prevent the blade from rotating by using the supplied wrench.

Use the 5mm allen key to open the blade attachment screw.

Remove the securing screw and washer (FIGURE P / 3), the outer blade flange (FIGURE P / 4) and the blade (FIGURE P / 5).

Before installing a new blade, check that both blade flanges are clean. Place a new or sharpened blade on the back flange (FIGURE P / 6), so that the marked side of the blade is facing outwards and the arrows on the blade are facing in the same direction as the rotation direction markings on the inside of the blade cover. Ensure that the new blade goes right to the bottom on the back blade flange. Put the outer blade flange, and the securing bolt back in place. Hold the blade with the wrench and tighten the blade securing nut. Put the blade guard cover back in place and tighten blade cover bolts.

FIGURE P

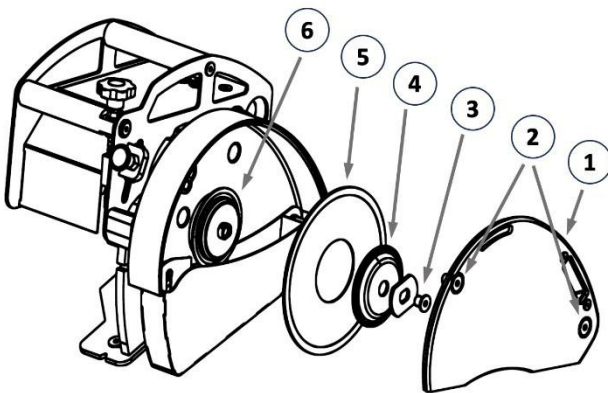

### Maintenance and servicing instructions

Remove the hydraulic hoses from the power source before servicing or cleaning the pipe saw. All repair operations carried with on the pipe saw must be carried out by an approved service center or engineer.

#### Blade

Check the condition of the blade. Replace a bent, blunt, or otherwise damaged blade with a new one. Using a blunt blade can overload the pipe saw's hydraulic motor. When you notice that the blade is blunt do not continue cutting with it, as the blade may become so badly damaged that it will not be worth sharpening. A blade in sufficiently good condition can be sharpened a few times by a professional sharpening company. Diamond X Discs cannot be sharpened

#### Carrier units

Clean the carrier units regularly with compressed air. Lubricate the carriers quick release axles and tightening screws (FIGURE Q / 1 and 2). Clean and lubricate also the chain from time to time to ensure smooth operation of Pipe Cut Infinity.

#### Blade guard

**⚠ WARNING:** Regularly check the correct function of the lower blade guard. To check the function, first disconnect the tool from hydraulic pressure source and then lift the lower blade guard to upper position by hand. After releasing the blade cover, it should return to lowest position without any delay or friction.

When you have cut plastic pipes and then intend to start cutting metal pipes always clean the inside of the blade guards. Hot metal particles originating from metal

cutting will heat up plastic particles, which may release toxic smoke. Make it a rule to clean the blade guard regularly and pay special attention to keep the moving blade guard movement from becoming obstructed. Lubricate the axis of the moving blade guard regularly.

FIGURE Q

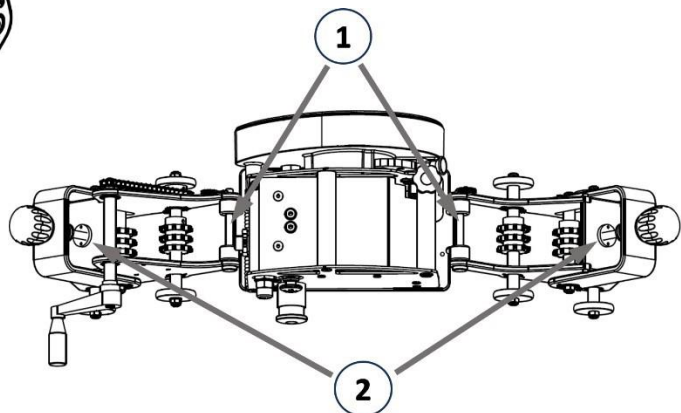

### Plastic and painted parts

Clean the plastic parts with a soft rag. Use only mild detergents. Do not use solvents or other strong detergents as they may damage the plastic parts and painted surfaces.

### Hydraulic hoses

Check the condition of hydraulic hoses regularly. Replace them if there is any signs of wear and tear on them.

Correct use and regular servicing and cleaning will ensure the reliable operation of the pipe saw.

### Environment

Separate collection. This product must not be disposed with normal household waste. When your Exact PipeCut machine is worn out, do not dispose it with normal household waste. This product must be recycled separately. Separate recycling of used products and packaging support recycling and recovery of materials. Reusing recycled materials helps preventing the pollution of the environment. According to local regulations it is possible to deliver household appliances to municipal rubbish depositories or to the dealer when purchasing a new product.

### Guarantee

#### Warranty terms valid from 01.01.2025.

If the Exact PipeCut saw becomes unusable due to material or manufacturing defects within the Warranty Term, at our discretion we will repair the Exact PipeCut Saw or supply an entirely new or factory reconditioned Exact PipeCut Saw at no charge.

The Exact HYDRA Infinity Warranty Term is for 24 months from date of purchase.

The Warranty is only valid if:

- 1.) Copy of a dated purchase receipt is returned to the Authorized Warranty Repair Center or has been uploaded to our website at the time of warranty registration.
- 2.) The Exact PipeCut Saw has not been misused.
- 3.) No attempt has been made by non-approved persons to repair the saw.
- 4.) The Exact PipeCut Saw has been used in accordance with the operating, safety, and servicing instructions provide in these instructions.
- 5.) The Exact PipeCut Saw has been delivered to an Authorized Warranty Repair Center within the warranty period.

**NOTICE! The Exact PipeCut Saw is to be shipped to the Authorized Warranty Repair Center freight prepaid. If the Exact PipeCut Saw is repaired under Warranty, the return shipment will be made freight prepaid.**

### CAUTION!

The following items or services are excluded for Warranty claims:

- Saw blades
- Carbon brushes (on electric machines)
- Blade or attachment flange
- Blade attachment nut or screw
- Normal wear
- Failures caused by misuse or accident
- Water, fire or physical damage
- Cables
- Adjustment of eccentric adjustment wheel
- If a wrong type of power pack etc. has been used as hydraulic power source.

### Exact Pipe Cut operation tips

Diamond blades can only be used for cutting cast or ductile iron pipes. This pipe material is not recommended to cut using to a blade of any other type.

Clean the inside of the blade guards after cutting plastic pipes.

Check the condition of the blade regularly.

The cutting process is divided into two stages: first you need to cut through the pipe wall and then cut around the pipe.

Maintain a uniform feed rate. This increases the lifespan of the blade.

When not cutting, keep the motor unit in the up position. Never attach the tool to the pipe with motor unit in locked down / cutting position.

**Factors influencing blade lifespan:**

- Pipe material
- Blade suitability for the pipe material
- Correct motor speed setting
- Pipe wall thickness
- Feed rate
- Smoothness of the pipe
- General user knowledge
- Cleanliness of the pipe
- Corrosion on pipe
- Weld seam on the pipe
- Blade speed

**Factors influencing straightness of cutting:**

- Blade condition
- Pipe wall thickness
- Feed rate
- Smoothness of feed
- General user knowledge
- Cleanliness of the pipe
- Pipe circumference
- Too loose or tight gripping device
- Too tight blade

**Additional attaching chain segments**

When cutting larger pipes is required, capacity beyond 1850mm can be achieved with additional chain segments. Chain segments are available in 2m pieces. These segments, together with the supplied segments, will allow attaching Exact Infinity to all pipe sizes.

**Blade suitability**

**Exact TCT:** Suitable for cutting steel and all kinds of plastic pipe material

**Exact Cermet:** Suitable for cutting stainless steel and acid proof materials, steel, copper, aluminum and all kind of plastic pipe materials.

**Exact ALU:** Suitable for cutting aluminum and all kinds of plastic.

**Exact Diamond:** Suitable only for cutting cast and ductile iron pipe materials, also for concrete lined cast iron pipes.

Exact TCT 140  
Exact Cermet 140  
Exact INOX 140  
Exact INOX Thin 140  
Exact ALU 140  
Exact Diamond X 140

Exact TCT 165  
Exact Cermet 165  
Exact ALU165  
Exact Diamond X 165

Exact Cermet 180  
Exact ALU 180  
Exact Diamond X 180



Due to continuous product development, the manual may be updated.  
No changes will be reported separately.

For more information check [www.exacttools.com](http://www.exacttools.com)

## Extra equipment for PipeCut Infinity HYDRA: Exact Cut+Bevel package for cast iron / ductile pipes

### Cut+Bevel features

When using Diamond Cut + Bevel disc, the bevel depth and width is adjusted with depth adjustment dial (Figure S). Turning the dial clockwise will make deeper and wider bevel and turning it counterclockwise will make smaller and thinner bevel.

Please note that the adjustment dial only affects the position where the motor unit is locked down. It does not move the motor unit if it is not locked down.

When using the machine on a new pipe size, adjust the cutting depth higher than needed prior to cutting. It is easier to make the cut deeper by adjusting the depth adjustment dial during cutting. Correct depth setting is confirmed with visual evaluation of the cutting result. The depth setting does not change if the depth adjustment dial is not moved. Therefore Cut + Bevel cuts can be made on same size pipes without any additional adjustment.

Beveling forces will push the saw to the right. To compensate these and achieve a straight cut, motor unit needs to be turned counterclockwise. The size of this adjustment depends on the pipe material, wall thickness, and bevel size. Therefore, it is not possible to provide a single optimal adjustment position.

To make the adjustment:

- Loosen the two screws on the body plate
- Turn body plate counterclockwise
- Tighten the screws

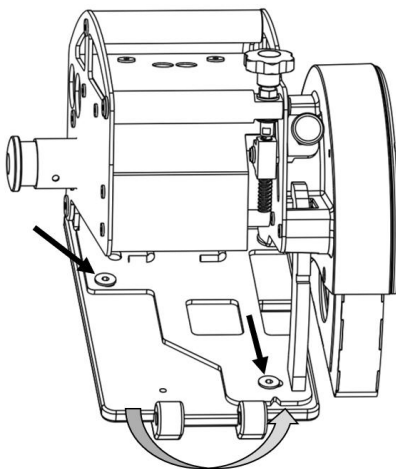

### Changing the lower blade guard

When using the Cut+Bevel Diamond disc, be sure to use also the lower blade guard with wide opening on the bottom. Regular lower blade guard does not work with Cut+Bevel Diamond disc.

Lower blade guard is changed as follows (Figure R):

- Remove blade and blade flanges from the saw if fitted.

### FIGURE R

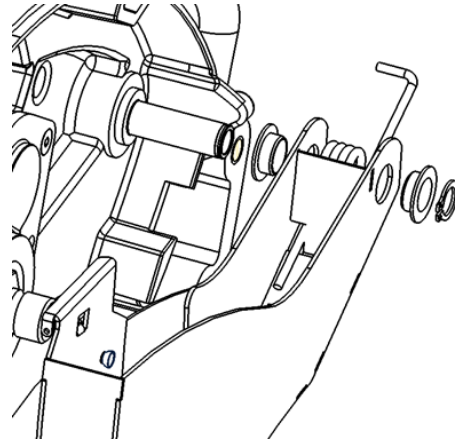

- Remove the retaining ring from the axle.
- Pull the lower blade guard, washer, spring and bushings of the axle. Note the locations of bushing and spring.
- Insert bushings into the lower blade guard to be installed
- Insert the lower blade guard with bushings, washer and spring on the axle. Be sure to locate the spring correctly.
- Test the correct function of the lower blade guard, it will return to low position when released and that it can move without any restriction.

### FIGURE S

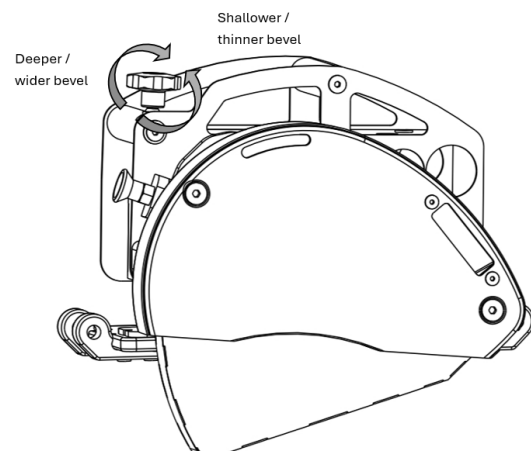

**Maximum recommended pipe wall thicknesses of different materials, which can be cut by Exact Pipe Cut Infinity****Pipe Cut Infinity**

Steel pipes	Max.pipe wall thickness 25 mm (1")
Stainless steel pipes	Max.pipe wall thickness 25 mm (1")
Cast or ductile iron pipes	Max.pipe wall thickness 25 mm (1")
Plastic, aluminum, copper	Max.pipe wall thickness 45 mm (1.4")

**ATTENTION!** Do not cut pipes thicker than the above-mentioned wall thickness.

**ATTENTION!** Check the status and condition of the blade before cutting