

# exact

## PipeBevel 220E/360E

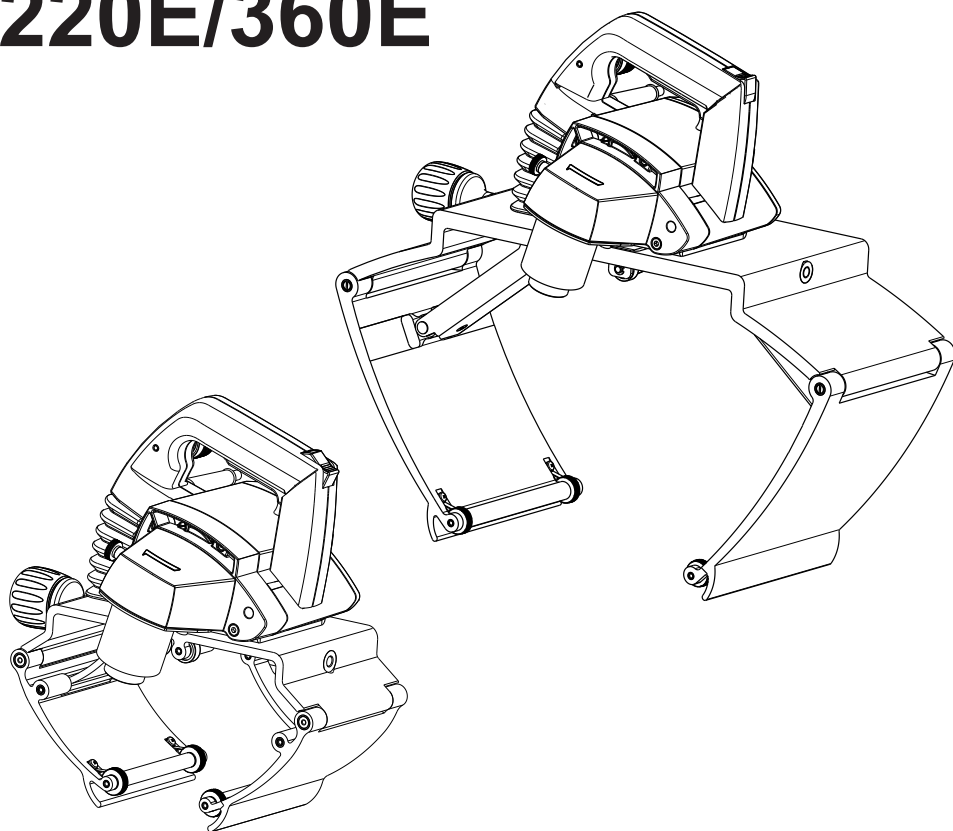

**EN** Operating Instructions

# Exact PipeBevel 220E/360E System

## Blade tip information for Exact PipeBevel

There are two different types of blade tips for Exact PipeBevel machines:

- Exact Bevel Tip Universal
- Exact Bevel Tip Stainless

Each blade tip has 4 cutting edges, so when one edge gets dull turn a new sharp edge to be the one in action.

**Note:** If one blade tip edge gets dull or a fragment of it breaks, you have to turn sharp edge from every tip of the blade holder. **All the time every cutting edge has to be in similar condition.**

Exact PipeBevel 220E speed control recommendations:

Stainless steel	5
Steel	6
Aluminium	6

## Figure A

1. UNLOCK button
2. Power switch
3. Power switch locking lever
4. Bevel level control bar screw
5. Rotation direction arrow
6. Blade cover
7. Reference bearing
8. Braking wheels
9. Guidance wheels
10. Operating handle
11. Motor unit adjustment screw
12. Motor unit
13. Blade cover key
14. Rating plate
15. Rpm regulator
16. Gripper unit
17. Gripper adjustment handle

**A**

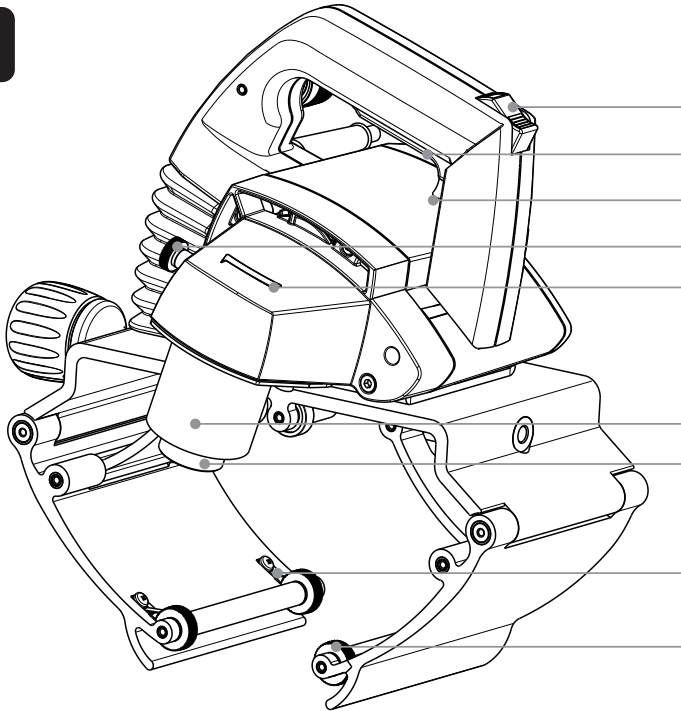

- 1.
- 2.
- 3.
- 4.
- 5.
- 6.
- 7.
- 8.
- 9.

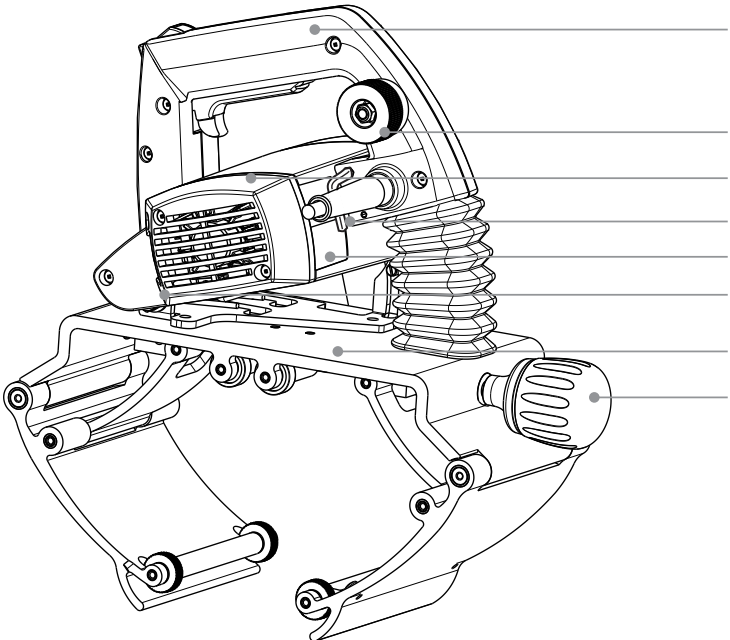

- 10.
- 11.
- 12.
- 13.
- 14.
- 15.
- 16.
- 17.

# Declaration of Conformity

We declare under our sole responsibility that the pipe cutting machines Exact PipeCut V800 Described under "Technical Data" are in conformity with the following standards or standardization documents:

EN 62841-1:2015 + A11:2022, EN 62841-2-5:2014,  
EN 55014-1:2017 + A11:2020, EN 55014-2:1997 + A2:2008, EN 61000-3-2:2014, EN  
61000-3-3:2013, according to the technical provisions of the directives 2006/42/EC and 2014/30/  
EU

For more information, please contact Exact Tools at the address below.

The technical file is available at the address underneath

The person authorized to compile the technical file:

Marko Törrönen, Chief Technology Officer, Exact Tools Oy ([marko.torronen@exacttools.com](mailto:marko.torronen@exacttools.com))

Helsinki, 02.01.2024

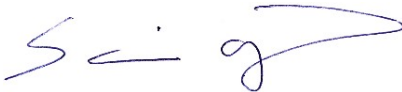

Sami Ojamo  
Managing Director  
Exact Tools Oy  
Martinkyläntie 41  
FI-01720 Vantaa  
Finland

## Contents

### Safety

- 2 Blade tip information for Exact PipeBevel 220E/360E
- 2 Product features
- 3 Product features figure
- 4 Declaration of Conformity
- 6 Technical data
- 7 Package contents
- 8 Safety instructions

### Operation

- 12 Functional Description
- 13 Before Operating the tool
- 14 Attaching the beveller to the pipe
- 14 Approaching the pipe wall
- 14 Beveling the pipe
- 15 Spin-speed regulation and overload protection
- 16 Replacing new cutting tips / Turning sharp edges of the cutting tips /  
Changing the complete cutting head
- 17 Service and maintenance instructions
- 17 Environment / Disposal
- 17 Guarantee
- 18 Tips

## Definitions: Safety guidelines

The definitions below describe the level of severity for each signal word. Please read the manual and pay attention to these symbols.



**DANGER:** Indicates an imminently hazardous situation which, if not avoided, will result in death or serious injury.



**WARNING:** Indicates a potentially hazardous situation which, if not avoided, could result in death or serious injury.



**CAUTION:** Indicates a potentially hazardous situation which, if not avoided, may result in minor or moderate injury.



**NOTICE:** Indicates a practice not related to personal injury which, if not avoided, may result in property damage.



**Denotes risk of electric shock.**

## Operating, safety, and servicing instructions

Please read these operating, safety, and servicing instructions carefully before using the beveller. Also store this instruction book somewhere accessible to everyone using the pipe beveling machine. In addition to these instructions, always follow the official work, health and safety regulations. The Exact PipeBevel 220E/360E is meant for professional use only.

## Technical data

Model	PipeBevel 220E	PipeBevel 360E
Voltage EU	220 - 240 V / 50 - 60 Hz 5,6 A	220 - 240 V / 50 - 60 Hz 5,6A
Voltage US	110-120V / 60Hz 9.2 A	110-120V / 60Hz 9.2 A
Power EU	1495 W	1495 W
Power US	1440 W	1440 W
No-Load speed	3500 - 8000 / min	3500 - 8000 / min
Intermittent operation	2.5 min ON / 7.5 min OFF (S3 25%)	2.5 min ON / 7.5 min OFF (S3 25%)
Blade holder diameter	1.88" (48 mm)	1.88" (48 mm)
Blade tip	0.60"x 0.60" (15.4 mm x 15.4 mm)	0.60"x 0.60" (15.4 mm x 15.4 mm)
Weight	14.7 lbs (6.7 kg)	25.7 lbs (11.7 kg)
Range of use Ø	1"-8.6" (25 mm-220 mm)	4.3"-14" (110 mm-360 mm)
Max. pipe wall	0.4" (10 mm)	0.4" (10 mm)
Protection class	□ / II	□ / II
Spindle lock	YES	YES
Speed preselection	YES	YES
Constant electronic control	YES	YES
Overload Protection	YES	YES
Reduced starting current	YES	YES
Vibration a <sub>h</sub>	< 2.5 m/s <sup>2</sup>	< 2.5 m/s <sup>2</sup>
LpA (sound pressure)	86 dB(A)	94 dB(A)
KpA (sound pressure uncertainty)	3 dB(A)	3 dB(A)
LWA (acoustic power)	97 dB(A)	105 dB(A)
KWA (acoustic power uncertainty)	3 dB(A)	3 dB(A)

The values given are valid for nominal voltages [U] of US 110-120 V and EU 220-240 V.

Please observe the article number on the rating plate of your machine. The trade names of the individual machines may vary. Only for power tools without reduced starting current: Starting cycles generate brief voltage drops. Interference with other equipment/machines may occur in case of unfavourable mains system conditions. Malfunctions are not to be expected for system impedances below 0.36 ohm.

## Noise/Vibration Information

Measured values determined according to EN60745.

### Wear hearing protection!

Vibration total values (triax vector sum) determined according EN60745:

Vibration emission value  $a_{H1} = < 2.5 \text{ m/s}^2$ , Uncertainty  $K = 1.5 \text{ m/s}^2$ .

The vibration emission level given in this information sheet has been measured in accordance with a standardized test given in EN 60745 and may be used to compare one tool with another. It may be used for a preliminary assessment of exposure.

**⚠ WARNING:** The declared vibration emission level represents the main applications of the tool. However if the tool is used for different applications, with different accessories or poorly maintained, the vibration emission may differ. This may significantly increase the exposure level over the total working period. An estimation of the level of exposure to vibration should also take into account the times when the tool is switched off or when it is running but not actually doing the job. This may significantly reduce the exposure level over the total working period. Identify additional safety measures to protect the operator from the effects of vibration such as: maintain the tool and the accessories, keep the hands warm, organization of work patterns.

## Exact PipeBevel 220E/360E system, Package contents:

Please check the package contains the following items:

1. Exact System shoulder bag
2. Exact PipeBevel 220E or 360E beveling machine
3. Beveling supports 2 pcs
4. Operating instructions
5. Hex socket key 5 mm fitted to the machine

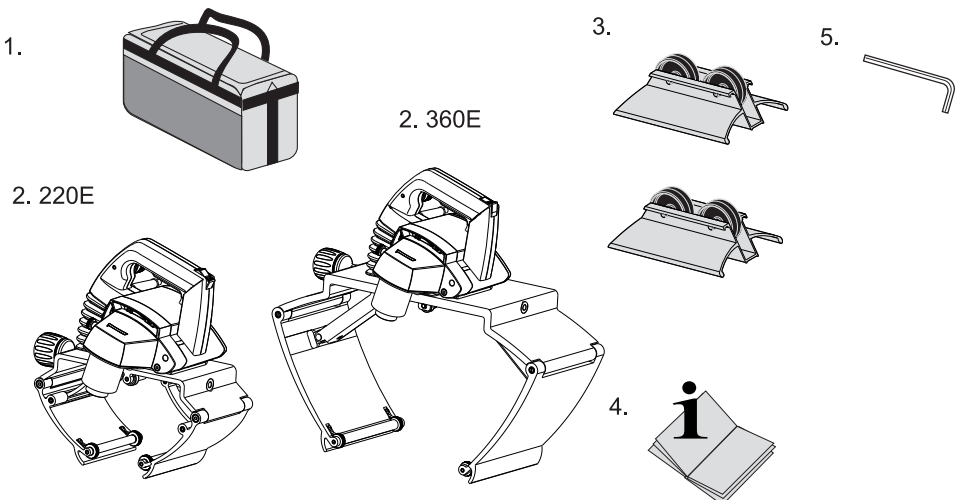

## General power tool safety warnings

 **WARNING: Read all safety warnings and all instructions.** Failure to follow the warnings and instructions may result in electric shock, fire and/or serious injury

**Save all warnings and instructions for future reference.**

The term “power tool” in the warnings refers to your mainsoperated (corded) power tool or battery-operated (cordless) power tool.

### 1. Work area safety

- Keep work area clean and well lit. Cluttered or dark areas invite accidents.
- Do not operate power tools in explosive atmospheres, such as in the presence of flammable liquids, gases or dust. Power tools create sparks which may ignite the dust or fumes.
- Keep children and bystanders away while operating a power tool. Distractions can cause you to lose control.

### 2. Electrical safety

- Power tool plugs must match the outlet. Never modify the plug in any way. Do not use any adapter plugs with earthed (grounded) power tools. Unmodified plugs and matching outlets will reduce risk of electric shock.
- Avoid body contact with earthed or grounded surfaces, such as pipes, radiators, ranges and refrigerators. There is an increased risk of electric shock if your body is earthed or grounded.
- Do not expose power tools to rain or wet conditions. Water entering a power tool will increase the risk of electric shock.
- Do not abuse the cord. Never use the cord for carrying, pulling or unplugging the power tool. Keep cord away from heat, oil, sharp edges and moving parts. Damaged or entangled cords increase the risk of electric shock.
- When operating a power tool outdoors, use an extension cord suitable for outdoor use. Use of a cord suitable for outdoor use reduces the risk of electric shock.
- If operating a power tool in a damp location is unavoidable, use a residual current device

(RCD) protected supply. Use of an RCD reduces the risk of electric shock.

### 3. Personal safety

- Stay alert, watch what you are doing and use common sense when operating a power tool. Do not use a power tool while you are tired or under the influence of drugs, alcohol or medication. A moment of inattention while operating power tools may result in serious personal injury.
- Use personal protective equipment. Always wear eye protection. Protective equipment such as dust mask, non-skid safety shoes, hard hat, or hearing protection used for appropriate conditions will reduce personal injuries.
- Prevent unintentional starting. Ensure the switch is in the off-position before connecting to power source, picking up or carrying the tool. Carrying power tools with your finger on the switch or energising power tools that have the switch on invites accidents.
- Remove any adjusting key or wrench before turning the power tool on. A wrench or a key left attached to a rotating part of the power tool may result in personal injury.
- Do not overreach. Keep proper footing and balance at all times. This enables better control of the power tool in unexpected situations.
- Dress properly. Do not wear loose clothing or jewellery. Keep your hair, clothing and gloves away from moving parts. Loose clothes, jewellery or long hair can be caught in moving parts.
- If devices are provided for the connection of dust extraction and collection facilities, ensure these are connected and properly used. Use of dust collection can reduce dust-related hazards.

### 4. Power tool use and care

- Do not force the power tool. Use the correct power tool for your application. The correct power tool will do the job better and safer at the rate for which it was designed.
- Do not use the power tool if the switch does not turn it on and off. Any power tool that cannot be controlled with the switch is dangerous and must be repaired.
- Disconnect the plug from the power source from the power tool before making any adjustments, changing accessories, or storing power tools. Such preventive safety measures reduce the risk of starting the power tool accidentally.

- d) Store idle power tools out of the reach of children and do not allow persons unfamiliar with the power tool or these instructions to operate the power tool. Power tools are dangerous in the hands of untrained users.
- e) Maintain power tools. Check for misalignment or binding of moving parts, breakage of parts and any other condition that may affect the power tool's operation. If damaged, have the power tool repaired before use. Many accidents are caused by poorly maintained power tools.
- f) Keep cutting tools sharp and clean. Properly maintained cutting tools with sharp cutting edges are less likely to bind and are easier to control.
- g) Use the power tool, accessories and tool bits etc. in accordance with these instructions, taking into account the working conditions and the work to be performed. Use of the power tool for operations different from those intended could result in a hazardous situation.

## 5. Service

Have your power tool serviced by a qualified repair person using only identical replacement parts. This will ensure that the safety of the power tool is maintained.

### **This section contains important safety information that is specific to this tool.**

Read and understand these instructions and the instructions and warnings for all equipment and materials being used before operating this tool to reduce the risk of serious personal injury.

Keep this manual with machine for use by the operator.

### **Beveller Safety**

- a) Always wear proper eye protection and hearing protection. Cutting tools can shatter or break. Be aware that cutting produces chips that can be thrown or fall into eyes. Cutting also produces high noise levels that over time can damage your hearing. Make sure that everyone around are also wearing pre-mentioned safety devices.
- b) Shields, long sleeves, safety shoes, hard hat, and other equipment as appropriate will reduce

the risk of injury. Always wear appropriate personal protective equipment and make sure bystanders use them as well.

- c) Do not wear loose clothing when operating with beveling machine. Keep sleeves and jackets buttoned or tied. Do not reach across machine. Clothing can be caught by the machine resulting in entanglement.
- d) Keep bystanders clear of work area. Chips or broken cutting tools can be thrown and cause injury beyond immediate area of operation. Make sure that bystanders are wearing eye protection, hearing protection, long sleeves, hard hat and safety boots and they are aware of risk of fast flying objects.
- e) One person must control the beveling machine during the beveling process. Beveling machine is designed for solo use only. Bystanders are not allowed to disturb user. This will reduce risk of injury.
- f) Make sure the pipe is supported properly and it is placed on pipe support or working stand. If you are working on non-rotating pipe, make sure the work pieces and its surroundings are stable and safe. Make sure the beveller is secure to the work piece. This will reduce the risk of striking and crushing injuries from tipping and falling pipe and equipment.
- g) Do not start the beveller with the cutter inserts touching the work piece. Let the cutter head reach full speed before carefully feeding it into the work piece. The cutter may bind, walk or kickback if the tool is started while in contact with the work piece.
- h) Make sure that rotating cutter head is completely stopped before handling the tool or pipe. Keep hands away from rotating cutter head. This practice will reduce the chance of entanglement in rotating parts.
- i) Do not use the pipe beveling machine for any undersigned purpose or modify it. Other uses or modifying the beveller for other applications may damage the tool, damage the attachments and/or cause personal injury.

Only drive beveller by hand. Use of power to drive the beveller can increase the risk of injury.

- j) Do not modify beveller or use for any other purpose. Other uses or modifying the beveller for other applications may damage the tool, damage the attachments and/or cause personal injury.
- k) Use proper respirator during the process. Avoid breathing of dust created from pipe beveling. Some dust created may contain chemicals known to cause cancer, birth defects or other serious personal injury. Consider the pipe material and coatings when determining appropriate respiratory protection, including things such as lead based paint. Your risk from these exposures varies, depending on how often you do this type of work and the concentration of dust. To reduce your exposure to these chemicals, work in a well ventilated area, and use respiratory protection selected based on appropriate regulations and standards, such as ANSI Z88.2 and OSHA.

## Additional specific safety rules

### The beveller must never be used in the following cases, if:

- There is water or another liquid, explosive gases or poisonous chemicals inside the pipe to be cut.
- The power switch is faulty.
- The power cable is faulty.
- The blade is bent.
- The blade is blunt or in poor condition.
- The plastic components are cracked or have parts missing.
- The gripper unit is not properly tightened around the pipe or if it is warped.
- The locking mechanisms do not work properly (UNLOCK-button).
- The beveller has become wet.

### When using the beveller, the following factors must always be taken into consideration:

- Support tubes to minimise the risk of blade pinching.
- Ensure that the pipe to be processed is empty.
- Ensure that the blade is correctly installed.
- Ensure that you are using suitable tips and desired beveling angle.
- Never use sideways force to stop the blade, always allow the blade to stop freely.
- Check the attachments of the blade guards.
- Never use excessive force when using the beveller.
- Never use the beveller to lift the pipe while it is still attached to the pipe.
- Avoid overloading the electric motor.
- Always follow the safety and operating instructions and current regulations.

Air vents often cover moving parts and should be avoided. Loose clothes, jewellery or long hair can be caught in moving parts.

Accessories must be rated for at least the speed recommended on the tool warning label. Accessories running over rated speed can fly apart and cause injury. Accessory ratings must always be above tool speed as shown on tool nameplate.

**⚠ WARNING:** ALWAYS wear proper personal hearing protection that conforms to ANSI S12.6 (S3.19) during use. Under some conditions and duration of use, noise from this product may contribute to hearing loss. When working with various materials, the sound level may vary and at times exceed the 85 dB(A) limit. Always use ear protectors to protect yourself.

**⚠ WARNING:** ALWAYS use safety glasses. Everyday eyeglasses are NOT safety glasses. Always use safety goggles to prevent injury to your eyes from particles thrown up when using the beveller. Also use face or dust mask if cutting operation is dusty (cast iron cutting).

**ALWAYS WEAR CERTIFIED SAFETY EQUIPMENT:**

- ANSI Z87.1 eye protection (CAN/CSA Z94.3),
- ANSI S12.6 (S3.19) hearing protection,
- NIOSH/OSHA/MSHA respiratory protection.

**⚠ WARNING:** ALWAYS use safety gloves as the edges of cut pipes are sharp and can cause cuts.

**⚠ WARNING:** Some dust created by power sanding, sawing, grinding, drilling, and other construction activities contains chemicals known to cause cancer, birth defects or other reproductive harm. Some examples of these chemicals are:

- lead from lead-based paints,
- crystalline silica from bricks and cement and other masonry products, and
- arsenic and chromium from chemically-treated lumber (CCA).

Your risk from these exposures varies, depending on how often you do this type of work. To reduce your exposure to these chemicals: work in a well ventilated area, and work with approved safety equipment, such as those dust masks that are specially designed to filter out microscopic particles.

Avoid prolonged contact with dust from power sanding, sawing, grinding, drilling, and other construction activities.

Wear protective clothing and wash exposed areas with soap and water. Allowing dust to get into your mouth, eyes, or lay on the skin may promote absorption of harmful chemicals.

**⚠ WARNING:** Use of this tool can generate and/or disburse dust, which may cause serious and permanent respiratory or other injury. Always use NIOSH/OSHA approved respiratory protection appropriate for the dust exposure. Direct particles away from face and body.

**⚠ WARNING:** Hold power tools by insulated gripping surfaces when performing an operation where the cutting tool may contact hidden wiring or its own cord. Contact with a "live" wire will make exposed metal parts of the tool "live" and shock the operator.

**⚠ WARNING:** Use clamps or another practical way to secure and support the workpiece to a stable platform. Holding the work by hand or against your body leaves it unstable and may lead to loss of control.

## Extension cords

An extension cord must have adequate wire size (AWG or American Wire Gauge) for safety. The smaller the gauge number of the wire, the greater the capacity of the cable, that is 16 gauge has more capacity than 18 gauge. An undersized cord will cause a drop in line voltage resulting in loss of power and overheating. When using more than one extension to make up the total length, be sure each individual extension contains at least the minimum wire size. The following table shows the correct size to use depending on cord length and nameplate ampere rating. If in doubt, use the next heavier gauge. The smaller the gauge number, the heavier the cord. (see page 4).

## Motor

Be sure your power supply agrees with nameplate marking. As little as 10% lower voltage can cause loss of power and can result in overheating. All Exact Tools products are factory-tested; if this tool does not operate, check the power supply.

**⚠ WARNING:** Accessories must be rated for at least the speed recommended on the tool warning label. Accessories running over rated speed can fly apart and cause injury. Accessory ratings must always be above tool speed as shown on tool nameplate.

**⚠ DANGER:** Avoid contact with the blade teeth to prevent personal injury

## Functional Description

### Read all safety warnings and all instructions.

Failure to follow the warnings and instructions may result in electric shock, fire and/or serious injury.

## Intended Use



### PipeBevel 220E/360E:

The Exact PipeBevel 220E/360E Pipe Beveling machine is intended for use as pipe fitter's or welder's tool at installation site. The PipeBevel 220E/360E can only be used to bevel round pipes, with diameter of 220E: 1"–8.6" (25 mm –220 mm) or 360E: 4.3"–14" (110 mm – 360 mm) and maximum bevel depth in 0.4" (10 mm) with steel and other ferrous and non-ferrous materials. The PipeBevel 220E/360E pipe beveller can be used to bevel normal weldable pipe materials, such as steel, aluminium and stainless steel. PipeBevel 220E/360E pipe beveling machine is intended for short and intermitten use. The Machine may be loaded for 2.5 minutes during a 10-minute period (S3 25 %). PipeBevel 220E/360E pipe beveling machine is not intended for rapid use, such as industrial prodcution. Use Pipe Holders to support pipe.

# Exact PipeBevel 220E/360E pipe beveling system operating instructions

## Before operating the tool

Ensure that the motor unit is in the upright position. The yellow mark of the UNLOCK button should be visible.

Check that the blade holder and the blade tips are correctly fitted, in good condition and suitable for the material to be beveled.

Ensure the pipe bevel machines gripping unit's wheels rotate.

Ensure the support wheels rotate.

Check the operation of the motor unit adjustment screw.

Ensure that the bevel level control bar is in the upper position (Fig C).

Ensure that the pipe is empty.

## Connection to the mains power supply

Ensure that the mains voltage is the same as indicated on the rating plate (Figure A/14). Connect the pipe beveling machine to the power outlet only after having checked this.

## Setting the pipe on supports

Use the system supports when beveling pipes. This will ensure safe working and optimum result. Work on flat surface. Place the pipe on the two supports (Fig B) that are supplied with the system. Check that all support wheels contact the pipe (adjust if required e.g. with pieces of lumber).

Fig C

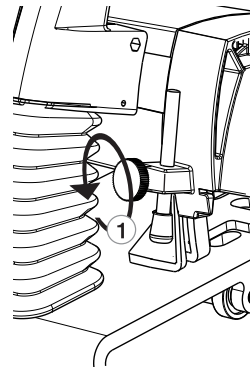
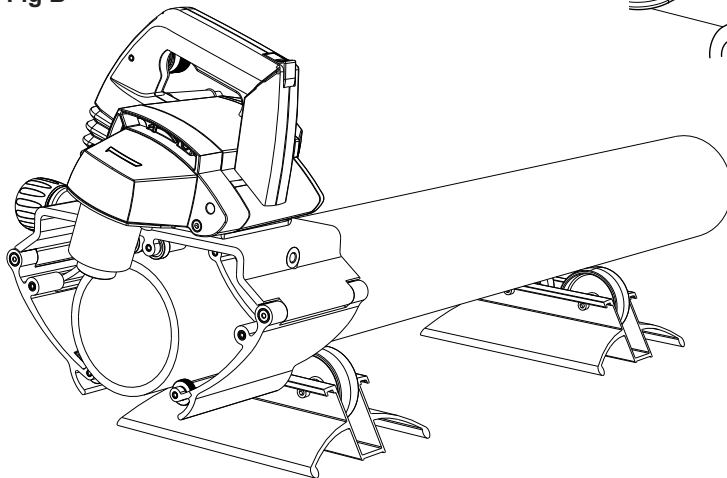

Fig B



## Attaching the beveller to the pipe

Open the beveller gripper unit enough by rotating the adjustment handle located at the rear of the beveller (Fig. D/1) to suit the diameter of the pipe. Position the beveller on top of the pipe so that the reference bearing (Fig. A/7) touches the end of the pipe. Fasten the beveller to the pipe by turning the gripper adjustment handle until the gripper grips firmly the pipe (Figure D/2). Hold the pipe in place and ensure that beveller moves freely in the direction the pipe is fed. For safety reasons ensure that the cable of the beveller is loose. The beveller is now ready for operation.

Fig D

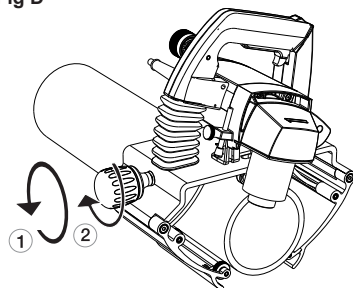

## Approaching the pipe wall

### NOTE:

Always ensure that the cutting head is in the uppermost possible position before you start working. The indicator tab (Fig P/1) should touch the aluminum block (Fig P/2). If cutting head is in wrong position when working is started, that will damage the blade and pipewall and can cause uncontrolled event.

Fig E

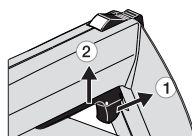
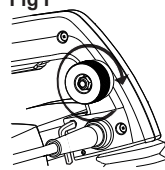
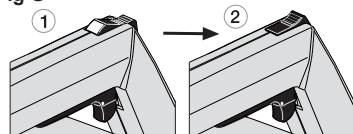

Fig F



Ensure also that the guiding bearing (Fig N) is faced on pipe wall correctly. The bearing should face the pipewall in 90 degree angle. If guiding bearing is not correctly placed it will effect in working and can cause damage in blades or pipe. Correctly placed guiding bearing ( Fig O / Fig N/1).

Fig G



Grip the operating handle (Fig A/10) firmly with your right hand and place your left foot on top of the pipe approximately 25" from the beveller. Turn the beveller until it leans slightly forward (Fig H). When starting the motor release the power switch locking lever (Fig E/1) and push the power switch all the way down (Fig E/2). Before starting to bevel, wait until the cutting head reaches full speed. Approach the pipe wall by rotating bevel depth adjustment knob clockwise (Fig F). By rotating the adjustment screw clockwise (Fig F) the cutting head moves towards the pipe (approximately 1 mm / round). Rotate the adjustment screw until the blades touches the pipe (you can hear and feel that point). Keep the motor running.

Fig H

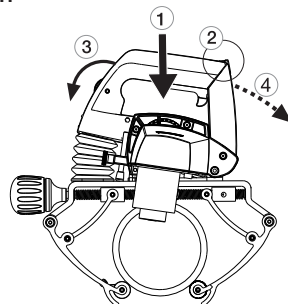

## Beveling the pipe

Keep the motor running all the time and rotate the adjustment screw still another 2–4 rounds clockwise. Start beveling by feeding the machine forward and hold the pipe with your left foot (Fig H/3). Thereafter release the pipe and turn the beveller backwards, whereby the pipe will follow (Fig J). Start a new feeding movement and feed continuously forward about 1/6 (Fig K) of the pipe's circumference. Repeat until there is an even bevel around the whole pipe.

Fig J

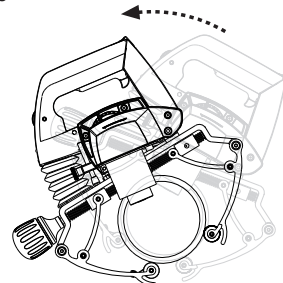

**NOTE:** Do not overload the beveler in process. Do not try to bevel too deep at once and make several turns around the pipe.

If more bevel is needed repeat the previously described procedure. **NOTE!** Turning one round the adjusting screw moves the cutting head about 1 mm.

The adjusting screw can be rotated during the beveling process to both directions – to increase (clockwise) or to decrease (counter clockwise) the bevel. Level of bevel can be visually controlled online and adjusted to the desired level.

When the pipe is beveled to the desired level, push the UNLOCK button forward (Fig L/1) until the locking is released. Lift the motor unit to starting position (Fig L/2) and release the power switch (Fig L/3). When the cutting head has stopped revolving remove the beveller from the pipe by loosening the gripper adjustment handle (Fig L/4). Ensure that the motor unit is in the upright position and the yellow mark is visible on the UNLOCK button. Now the beveller is ready for next pipe beveling.

If there are some problems during the beveling process – abnormal sounds or vibrations due to which you have interrupt beveling before the pipe end is ready. Release the cutting head by pushing the UNLOCK button forward until the UNLOCK button is released, and lift the motor unit up. Once the problem is cleared, start beveling again.

Never start the motor when the cutting head is touching the pipe. The cutting tips might break or get otherwise damaged.

There is a possibility to maintain the chosen bevel level. When you have reached the desired bevel depth, open the stop bar screw (Fig A/4 + C/1) and the bar will touch down, and then tighten the same screw. Now you have a reference for the depth of the bevel.

### Spin-speed regulator and overload protection

There is a spin-speed regulator in the beveling machine (Fig A/15). A suitable spin speed is selected, determined by the material to be beveled (see page 2). There is also an automatic overload protection in the regulator.

In the case of overload: Release the power switch and push the UNLOCK button forward until the yellow mark is visible and the locking is released. When loaded too much the machine the regulator cuts the circuit and stops the motor. When the motor stops due to the overload, the red light on the beveller is turned on. The beveller has to cool down. The motor will not start (even the red light has turned off) until the switch is released and pressed once more time or the plug is disconnected and reconnected.

The indicator's red light turns on for a second every time when the motor is started. This in normal and does not require any actions.

Fig K

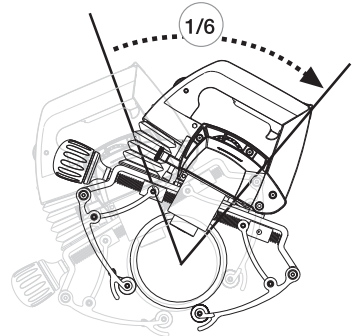

Fig L

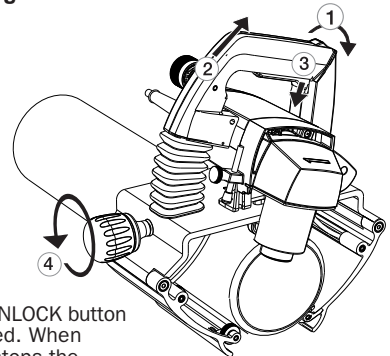

Fig N

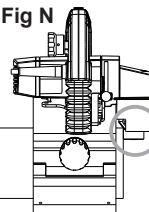

Fig O

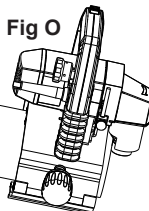

Fig P

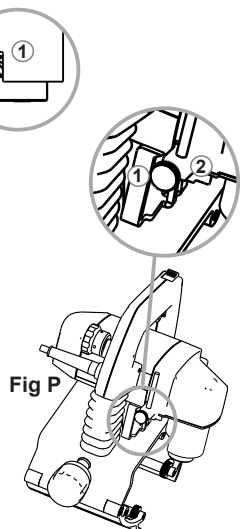
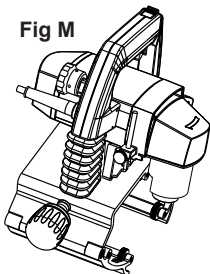

Fig M



## Replacing new beveling tips / turning sharp edges of the beveling tips / changing the complete cutting head

**⚠ WARNING:** To reduce the risk of injury, turn unit off and disconnect it from power source before installing and removing accessories, before adjusting or when making repairs. An accidental start-up can cause injury.

Remove the power plug from the socket. Check that the motor unit is locked in the upper position.

### How to replace or turn the cutting blades

Remove the cutting head cover (Fig Q/1) by loosening the screw a bit (Fig Q/2) with 5 mm allen key (supplied Fig A/13). Rotate the cutting head cover clockwise slightly so that the base plate is released. Now you can remove the cover.

Open the cutting blade screw (Fig Q/3) with TX 15 key. Remove and change the cutting blade or turn the cutting blade 90 degrees to use a new sharp cutting edge of the blade (please note that all the 4 edges of the cutting blade can be used). Tighten the screws properly. Place the cutting head cover back and tighten the screw properly.

**⚠ NOTICE:** All three cutting blades have to be replaced or turned 90 degrees at the same time.

### How to change the complete cutting head

If you need to achieve a different bevel angle than the standard 37.5 degrees you have to change the cutting head. First remove the cutting head cover as described earlier. Remove the cutting head with two wrenches (17 mm and 19 mm). The thread is normal right hand thread. Screw the new cutting head to it's place and tighten properly with two wrenches. Assemble the cutting tips and finally the cutting head cover.

**NOTE!** The beveling angle for the standard cutting head is 30, 37.5 or 45 degrees.

Fig Q

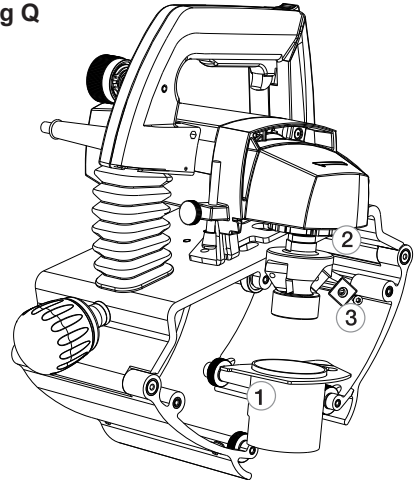
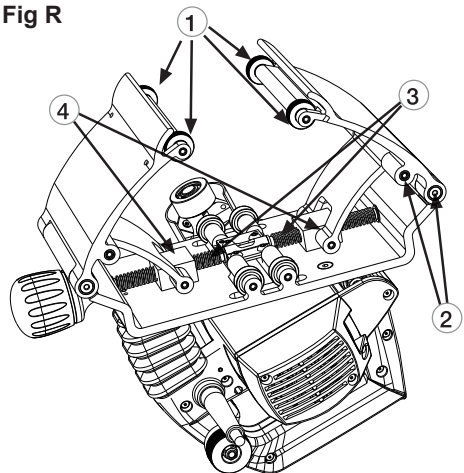

Fig R



## Maintenance and servicing instructions

Remove the power plug from the socket before servicing or cleaning the beveller. All maintenance operations to some of bevellers electrical components must be carried out at an approved service agency.

### Cutting head

**⚠ WARNING:** Check the condition of the blade tips regularly. Replace blunt, or otherwise damaged blade tips with a new set. Using a blunt blade tips can overload the beveller's electric motor. They might also crack and this may cause danger to the operator or property.

### Gripper unit

Clean the gripper unit regularly with compressed air. Lubricate the gripper's wheel axis (Fig N/1) and its joints (Fig N/2). Also clean and lubricate the gripper's trapezoidal screw (Fig N/3) and the two worm screws on it (Fig N/4).

### Cutting head guard

**⚠ WARNING:** Check the condition of the Cutting head guard regularly. It should not move, wobble or shake at all. If it does, do not use the machine. Using the machine with damaged cutting head guard may cause danger to the user or property.

### Motor

Keep the motor's cooling vents clean.

### Plastic parts

Clean the plastic parts with a soft rag. Only use mild detergents. Do not use solvents or other strong detergents as they may damage the plastic parts and paint surfaces.

### Power cable

**⚠** Check the condition of the power cable regularly. A faulty power cable should always be replaced at an approved service agency.

Correct use and regular servicing and cleaning will ensure the continued operation of the beveller.

## Environment



Separate collection. This product must not be disposed of with normal household waste. When your Exact product is worn out, do not dispose of it with normal household waste. This product must be recycled separately. Separate recycling of used products and packaging facilitate recycling and recovery of materials. Reusing of recycled materials helps prevent pollution of environment. According to local regulations it is possible to deliver household appliances to municipal rubbish depositories or to the dealer when buying a new product.

## Guarantee

### Warranty terms valid from 01.01.2015

If the Exact product becomes unusable due to material or manufacturing defects within the **warranty term**

or discretion we will repair the Exact product or supply an entirely new or factory reconditioned

### Warranty term

The Exact Tools warranty term is 12 months from date of purchase.

### The warranty is valid if

- 1.) Copy of a dated purchase receipt is returned to the Authorized Warranty Repair Center or has been uploaded to our website at the time of warranty registration.
- 2.) The Exact product has not been misused.
- 3.) No attempt has been made by non-approved persons to repair the beveller.
- 4.) The Exact product has been used in accordance with the operating, safety, and servicing instructions provided in the manual.
- 5.) The Exact product has been delivered to an Authorized Warranty Repair Center within the term of the warranty.

**Note:** The Exact product is to be shipped to the Authorized Warranty Repair Center freight prepaid. If the Exact product is repaired under Warranty the return shipment will be made freight prepaid. If the Exact product is not repaired under Warranty the return shipment will be made freight collect.

**Please Note: The following items or services are excluded from Warranty claims:**

- Bevel tips
- Cutting heads
- Overload Protection Fuse
- Carbon Brushes
- Gripping Unit Wheels
- Blade Flange
- Attachment Flange
- Pulling Flange Washer
- Normal Wear and Tear
- Errors Due to Misuse or Accident
- Water, Fire and Physical Damage
- Power Cords
- Adjustment of Adjustment Wheel

Due to continuous product development, the information in this instruction book may change. We do not give separate notification of changes.

## Tips for using Exact PipeBevel-beveling machines

Make sure there is no dirt or other interfering objects in under the cutting head cover.

Smaller pipe is easily beveled by rotating the pipe by hand either on a table or on the floor. Please note: rotate pipe towards you when rotating by hand and be careful not to rotate too fast.

Check the condition of the blade tip regularly. The beveling procedure is divided into several stages; first bevel the surface of pipe wall, then complete the bevel by going deeper with adjustment wheel. Make several turns and adjust the bevel depth several times, depending the thickness of pipe and hardness of beveled material. Always go one full round before adjusting bevel depth.

You can easily repeat desired bevel depth with control bar. Lock the control bar as you have reached desired bevel depth.

Do not overload the beveling machine. If the beveling will be overheated the metal parts can become burning hot. This will also damage the motor and the blade tips. The rule is 2.5 minutes in use and 7.5 minutes rest.

Keep the feeding speed constant. This will extend the lifetime of the blade tip. Do not use extra force and be careful that you are not beveling too much at once. This affects quality of bevel and blade life. If you try to remove too much material at once, you can damage the blade and beveled pipe. Rule of thumb: more little you take, more better your bevel quality is.

Always keep the motor unit in the upright position. The yellow mark of the unlock button is then visible. Never place the beveller on the pipe in the locked / beveling position. Wrongly possessed tool can kick back and it can be dangerous.

**Factors that affect the lifetime of the blade tip:**

- material of the pipe
- correct blade type for material being cut
- correct motor speed setting
- wall thickness of the pipe
- feeding speed
- smoothness of the pipe
- user's general skills
- coatings of the pipe
- rust on the pipe
- welded seam in the pipe
- blade speed

Please see more information at our web-site  
[www.exacttools.com](http://www.exacttools.com)



**exact**

**Exact Tools Oy  
Särkiniementie 5 B 64  
00210 HELSINKI  
FINLAND**

**Tel + 358 9 4366750  
FAX + 358 9 43667550  
[exact@exacttools.com](mailto:exact@exacttools.com)  
[www.exacttools.com](http://www.exacttools.com)**